



# PRINCIPLES OF AUTOMATION AND CONTROL

Editor:

**Ilesanmi Afolabi Daniyan**

**Bentham Books**

# **Principles of Automation and Control**

Edited By

**Ilesanmi Afolabi Daniyan**

*Department of Industrial Engineering*

*Tshwane University of Technology*

*Pretoria-0001*

*South Africa*

# **Principles of Automation and Control**

Editor: Ilesanmi Afolabi Daniyan

ISBN (Online): 978-981-5080-92-6

ISBN (Print): 978-981-5080-93-3

ISBN (Paperback): 978-981-5080-94-0

© 2023, Bentham Books imprint.

Published by Bentham Science Publishers Pte. Ltd. Singapore. All Rights Reserved.

First published in 2023.

## **BENTHAM SCIENCE PUBLISHERS LTD.**

### **End User License Agreement (for non-institutional, personal use)**

This is an agreement between you and Bentham Science Publishers Ltd. Please read this License Agreement carefully before using the ebook/echapter/ejournal (“**Work**”). Your use of the Work constitutes your agreement to the terms and conditions set forth in this License Agreement. If you do not agree to these terms and conditions then you should not use the Work.

Bentham Science Publishers agrees to grant you a non-exclusive, non-transferable limited license to use the Work subject to and in accordance with the following terms and conditions. This License Agreement is for non-library, personal use only. For a library / institutional / multi user license in respect of the Work, please contact: [permission@benthamscience.net](mailto:permission@benthamscience.net).

### **Usage Rules:**

1. All rights reserved: The Work is the subject of copyright and Bentham Science Publishers either owns the Work (and the copyright in it) or is licensed to distribute the Work. You shall not copy, reproduce, modify, remove, delete, augment, add to, publish, transmit, sell, resell, create derivative works from, or in any way exploit the Work or make the Work available for others to do any of the same, in any form or by any means, in whole or in part, in each case without the prior written permission of Bentham Science Publishers, unless stated otherwise in this License Agreement.
2. You may download a copy of the Work on one occasion to one personal computer (including tablet, laptop, desktop, or other such devices). You may make one back-up copy of the Work to avoid losing it.
3. The unauthorised use or distribution of copyrighted or other proprietary content is illegal and could subject you to liability for substantial money damages. You will be liable for any damage resulting from your misuse of the Work or any violation of this License Agreement, including any infringement by you of copyrights or proprietary rights.

### ***Disclaimer:***

Bentham Science Publishers does not guarantee that the information in the Work is error-free, or warrant that it will meet your requirements or that access to the Work will be uninterrupted or error-free. The Work is provided "as is" without warranty of any kind, either express or implied or statutory, including, without limitation, implied warranties of merchantability and fitness for a particular purpose. The entire risk as to the results and performance of the Work is assumed by you. No responsibility is assumed by Bentham Science Publishers, its staff, editors and/or authors for any injury and/or damage to persons or property as a matter of products liability, negligence or otherwise, or from any use or operation of any methods, products instruction, advertisements or ideas contained in the Work.

### ***Limitation of Liability:***

In no event will Bentham Science Publishers, its staff, editors and/or authors, be liable for any damages, including, without limitation, special, incidental and/or consequential damages and/or damages for lost data and/or profits arising out of (whether directly or indirectly) the use or inability to use the Work. The entire liability of Bentham Science Publishers shall be limited to the amount actually paid by you for the Work.

### **General:**

1. Any dispute or claim arising out of or in connection with this License Agreement or the Work (including non-contractual disputes or claims) will be governed by and construed in accordance with the laws of Singapore. Each party agrees that the courts of the state of Singapore shall have exclusive jurisdiction to settle any dispute or claim arising out of or in connection with this License Agreement or the Work (including non-contractual disputes or claims).
2. Your rights under this License Agreement will automatically terminate without notice and without the

need for a court order if at any point you breach any terms of this License Agreement. In no event will any delay or failure by Bentham Science Publishers in enforcing your compliance with this License Agreement constitute a waiver of any of its rights.

3. You acknowledge that you have read this License Agreement, and agree to be bound by its terms and conditions. To the extent that any other terms and conditions presented on any website of Bentham Science Publishers conflict with, or are inconsistent with, the terms and conditions set out in this License Agreement, you acknowledge that the terms and conditions set out in this License Agreement shall prevail.

**Bentham Science Publishers Pte. Ltd.**

80 Robinson Road #02-00

Singapore 068898

Singapore

Email: [subscriptions@benthamscience.net](mailto:subscriptions@benthamscience.net)



## CONTENTS

FOREWORD .....	i
PREFACE .....	ii
ACKNOWLEDGEMENTS .....	iii
DEDICATION .....	iv
LIST OF CONTRIBUTORS .....	v
<b>CHAPTER 1 INTRODUCTION TO THE PRINCIPLES OF AUTOMATION AND CONTROL</b> .....	1
<i>Ilesanmi Afolabi Daniyan</i>	
<b>CHAPTER 2 CONCEPTS OF AUTOMATION AND CONTROL</b> .....	5
<i>Ilesanmi Afolabi Daniyan, Lanre Daniyan, Adefemi Adeodu and Khumbulani Mpopu</i>	
<b>GENERAL INTRODUCTION AND DEFINITION OF BASIC CONCEPTS</b> .....	5
<b>MECHANIZATION AND AUTOMATION</b> .....	7
<b>AUTOMATION AND ARTIFICIAL INTELLIGENCE</b> .....	8
<b>CLASSES OF AUTOMATION</b> .....	9
Industrial Automation .....	9
Software Automation .....	11
Process Automation .....	11
<b>PROCEDURES FOR AUTOMATION DESIGN</b> .....	11
<b>MERITS AND DEMERITS OF AUTOMATION</b> .....	12
Merits of Automation .....	12
Demerits of Automation .....	13
<b>AUTOMATED PRODUCTION/ASSEMBLY/ FLOW LINES</b> .....	14
<b>TYPES OF WORKSTATIONS LAYOUT/CONFIGURATIONS</b> .....	14
In-Line or Straight Configuration .....	15
Segmented or Cellular Configuration .....	16
Fixed Layout Configuration .....	17
<b>CONCLUSION</b> .....	18
<b>REFERENCES</b> .....	18
<b>CHAPTER 3 AUTOMATED PROCESSES AND SYSTEMS</b> .....	20
<i>Saheed Akande, Wasiu Adeyemi Oke and Fawaz Aremu Babajide</i>	
<b>INTRODUCTION</b> .....	20
<b>AUTOMATION PROCESSES</b> .....	21
<b>ELEMENTS OF SYSTEM AUTOMATION</b> .....	21
<b>THE POWER TO ACCOMPLISH THE PROCESS AND OPERATE THE SYSTEM</b> .....	22
<b>PROGRAM OF INSTRUCTIONS</b> .....	22
<b>A CONTROL MECHANISM TO ACTUATE THE INSTRUCTION</b> .....	23
<b>THE TRANSFER FUNCTION</b> .....	23
Open-loop System .....	23
A Closed-loop Control System .....	25
i. Positive Feedback .....	26
ii. Negative Feedback .....	26
<b>CLASSES OF AUTOMATED SYSTEMS</b> .....	27
Fixed or Hard Automation .....	27
Programmable Automation .....	28
Flexible Automation .....	28
Integrated Automation .....	28
<b>PROGRAMMABLE LOGIC CONTROLLER (PLC) PROGRAMMING</b> .....	29

The Input and Output (I/O) Modules .....	29
<b>ANALOGUE INPUTS AND ANALOGUE OUTPUT</b> .....	30
Analogue Input Interface .....	30
Analogue Output Interface .....	32
<b>PLC PROGRAMING HIGHER FUNCTION</b> .....	32
<b>2-STEP CONTROLLER</b> .....	32
Characteristics of Hysteresis in a 2-Step Controller .....	35
Advantages of a 2-Step Controller .....	35
Disadvantages of a 2-Step Controller .....	35
<b>BASICS IN CLOSED LOOP CONTROL</b> .....	36
Comparison Element .....	36
Control Law Implementation Element .....	37
Correction Element .....	37
Process .....	37
Measurement Element .....	37
<i>Forward Path</i> .....	38
<i>Feedback Path</i> .....	38
Closed Loop Temperature Control .....	38
Closed Loop Level Control .....	41
Closed Loop Flow Control .....	45
Closed Loop Pressure Control .....	46
<b>CONCLUSION</b> .....	48
<b>REFERENCES</b> .....	49
<b>CHAPTER 4 LEVELS OF AUTOMATION</b> .....	50
<i>Ilesanmi Afolabi Daniyan, Lanre Daniyan, Adefemi Adeodu and Ikenna Uchegbu</i>	
<b>INTRODUCTION</b> .....	51
<b>AUTOMATION LEVELS</b> .....	51
Manual Level .....	52
Semi-Automatic Level .....	52
Fully Automatic Level .....	52
<b>ELEMENTS OF SYSTEM AUTOMATION</b> .....	53
Sensor .....	53
Controller and I/O .....	53
Actuator .....	54
Power Component .....	54
Motors and Drives .....	54
Communication .....	54
Human-Machine Interface (HMI) .....	54
<b>CLASSES OF AUTOMATED SYSTEMS</b> .....	55
Fixed Automation .....	55
Programmable Automation .....	56
Flexible Automation .....	56
Integrated Automation .....	57
Cognitive Automation .....	58
<b>CONCLUSION</b> .....	58
<b>REFERENCES</b> .....	58
<b>CHAPTER 5 THE CONTROL SYSTEM</b> .....	60
<i>Ilesanmi Afolabi Daniyan, Lanre Daniyan, Boitumelo Ramatsetse and Khumbulani Mpofo</i>	
<b>INTRODUCTION</b> .....	60

<b>THE CONTROL SYSTEM</b> .....	61
<b>FUNCTIONS OF THE CONTROL SYSTEM</b> .....	61
<b>TYPES OF CONTROL ACTIONS</b> .....	62
Discrete Control .....	62
Continuous Control .....	63
<i>Regulatory Control</i> .....	64
<i>Feed Forward Control</i> .....	64
<i>Steady-State Optimization</i> .....	64
<i>Adaptive Control</i> .....	65
<b>PROCESS CONTROL SYSTEM</b> .....	65
Temperature Control System .....	65
<i>Negative Temperature Coefficient (NTC) Thermistor</i> .....	66
<i>Resistance Temperature Detector (RTD)</i> .....	66
<i>Thermocouple</i> .....	66
<i>Semiconductor-Based Sensors</i> .....	66
Pressure Control System .....	67
Liquid Level Control System .....	67
Flow Rates Control System .....	67
Speed Control System .....	68
<b>TYPES OF CONTROL SYSTEMS</b> .....	68
Open Loop Control System .....	68
Closed Loop Control System .....	69
<i>Closed Loop Temperature Control in a Reactor</i> .....	72
<i>Closed Loop Temperature Control in a Motor</i> .....	72
Open and Closed Loop Control System .....	74
<b>THE SUMMING POINT OF A CLOSED LOOP SYSTEM</b> .....	74
<b>THE TRANSFER FUNCTION OF A CLOSED LOOP CONTROL SYSTEM</b> .....	75
<b>ELEMENTS OF THE CONTROL LOOP SYSTEM</b> .....	77
<b>TYPES OF VARIABLES</b> .....	79
Controlled Variable .....	79
Manipulated Variable .....	79
Disturbance Variables .....	79
<b>CLASSES OF CONTROL</b> .....	79
Manual Control Systems .....	80
Semi-Automatic Control Systems .....	80
Automatic Control Systems .....	80
<b>TYPES OF SYSTEM PROCESSES</b> .....	80
Batch Processing .....	80
Continuous Processing .....	81
Individual Processing .....	81
System's Error .....	81
<b>REPRESENTATION OF THE CONTROL SYSTEMS</b> .....	81
<b>PROPORTIONAL–INTEGRAL–DERIVATIVE (PID) CONTROLLER</b> .....	82
<b>THE CONTROL THEORY</b> .....	86
Linearization .....	86
Control Feedback Linearization .....	87
<b>CONCLUSION</b> .....	89
<b>REFERENCES</b> .....	89

**CHAPTER 6 COMPUTER CONTROL DEVICES IN AUTOMATION** ..... 91

*Ilesanmi Afolabi Daniyan, Lanre Daniyan, Adefemi Adeodu and Felix Ale*



<b>INTRODUCTION</b> .....	92
<b>PROGRAMMABLE LOGIC DEVICES (PLD)</b> .....	92
<b>APPLICATIONS OF PLAS AND PAL/GALS</b> .....	93
Processor .....	93
Memory .....	93
Input/Output Devices .....	94
<b>PROGRAMMABLE LOGIC CONTROLLER (PLC)</b> .....	94
<b>MICROPROCESSOR</b> .....	95
<b>MICROCOMPUTER</b> .....	96
<b>MICROCONTROLLER</b> .....	96
<b>PROGRAMMABLE AUTOMATION CONTROLLER (PAC)</b> .....	97
<b>CONCLUSION</b> .....	97
<b>REFERENCES</b> .....	98
<b>CHAPTER 7 INDUSTRIAL AUTOMATION TOOLS AND COMPONENTS</b> .....	99
<i>Ilesanmi Afolabi Daniyan, Lanre Daniyan, Felix Ale and Khumbulani Mpofu</i>	
<b>INTRODUCTION</b> .....	99
<b>TYPES OF INDUSTRIAL AUTOMATION TOOL</b> .....	100
The Artificial Neural Network (ANN) .....	100
The Distributed Control System (DCS) .....	100
Human-Machine Interfaces (HMI) .....	101
Supervisory Control and Data Acquisition System (SCADA) .....	101
Instrumentation .....	101
Robotics .....	102
<b>COMPONENTS OF AN INDUSTRIAL AUTOMATION SYSTEM</b> .....	102
<b>APPLICATIONS OF INDUSTRIAL AUTOMATION</b> .....	102
Robotics .....	103
<i>Artificially Intelligent Robots</i> .....	103
<i>Non-artificially Intelligent Robots</i> .....	103
Packaging System .....	105
Computer Numeric Control Systems .....	105
Tool Monitoring System .....	105
Advanced Inspection System .....	106
Flexible Manufacturing System .....	106
<b>CONCLUSION</b> .....	106
<b>REFERENCES</b> .....	106
<b>CHAPTER 8 PRACTICAL EXAMPLES OF SYSTEM AUTOMATION AND CONTROL</b> .....	108
<i>Ilesanmi Afolabi Daniyan, Lanre Daniyan, Adefemi Adeodu and Felix Ale</i>	
<b>INTRODUCTION</b> .....	108
<b>IRRIGATION SYSTEM</b> .....	109
<b>AUTOMATION OF THE IRRIGATION SYSTEM</b> .....	109
System Architecture .....	110
Waste Segregator .....	111
Gasifier .....	112
Biodiesel Plant .....	113
The Pressure Transducer .....	113
Temperature Sensor .....	114
The Timing System .....	114
Float Switch .....	114
Flow Meter .....	114
Buzzer .....	114

LM6009 and LM 2596 Modules .....	114
The Wireless Communication and SMS Module .....	115
Leakage Detection in the Pipeline .....	115
Biogas Plant .....	115
Lawn Mower .....	116
Alert System for Human Access Control .....	117
Arduino Uno Microcontroller .....	117
The Alert System .....	118
Reception System .....	119
The Alert System .....	119
The Actuation System .....	119
<b>AUTOMATION OF ASSEMBLY LINE .....</b>	<b>121</b>
<b>AUTOMATIC CONTROL OF THE SUSPENSION OF A RAILCAR .....</b>	<b>122</b>
<b>CONCLUSION .....</b>	<b>129</b>
<b>REFERENCES .....</b>	<b>129</b>
<b>CHAPTER 9 WATER DISTRIBUTION MANAGEMENT IN REAL TIME: USING A CLOUD-BASED APPROACH .....</b>	<b>131</b>
<i>Kazeem Aderemi Bello, Ilesanmi Afolabi Daniyan, Osato Alexendra Ighodaro, Adefemi Adeodu and Wasiru Adeyemi Oke</i>	
<b>INTRODUCTION .....</b>	<b>132</b>
<b>MATERIALS AND METHOD .....</b>	<b>138</b>
Materials .....	138
<i>Pump Design for Selection .....</i>	<i>139</i>
<i>Global System for Mobile Telecommunication (GSM) Module .....</i>	<i>141</i>
<i>Arduino Nano Microcontroller .....</i>	<i>142</i>
<i>Relay Module .....</i>	<i>142</i>
<i>Piezo Buzzer .....</i>	<i>143</i>
<i>Arduino Water Level Sensor .....</i>	<i>143</i>
<i>Liquid Crystal Display (LCD) .....</i>	<i>144</i>
Method .....	144
<b>RESULTS AND DISCUSSION .....</b>	<b>145</b>
<b>CONCLUSION .....</b>	<b>148</b>
<b>REFERENCES .....</b>	<b>149</b>
<b>CHAPTER 10 DEVELOPMENT OF AUTOMATED WASTE SEGREGATOR .....</b>	<b>152</b>
<i>Ilesanmi Afolabi Daniyan, Adefemi Adeodu, Jacobs Kelechi and Lanre Daniyan</i>	
<b>INTRODUCTION .....</b>	<b>152</b>
<b>MATERIALS AND METHOD .....</b>	<b>153</b>
The Assembly Phase .....	155
The Software Phase .....	156
<b>RESULTS AND DISCUSSION .....</b>	<b>156</b>
<b>CONCLUSION .....</b>	<b>158</b>
<b>REFERENCES .....</b>	<b>159</b>
<b>CHAPTER 11 DEVELOPMENT OF A FIRE DETECTION AND EXTINGUISHING ROBOT .....</b>	<b>161</b>
<i>Ilesanmi Afolabi Daniyan, Adefemi Adeodu, Bankole Oladapo, Vincent Balogun and Ididiong Etudor</i>	
<b>INTRODUCTION .....</b>	<b>161</b>
<b>METHODOLOGY .....</b>	<b>163</b>
Design Constraints and Specifications .....	164
Mechanical Design .....	165

Motor Size Determination .....	166
The Circuit Integration and Analysis .....	166
Performance Evaluation .....	167
<b>RESULTS AND DISCUSSION</b> .....	168
<b>CONCLUSION</b> .....	169
<b>REFERENCES</b> .....	169
<b>CHAPTER 12 PERFORMANCE SIMULATION OF A SOLAR-POWERED AND HAND GESTURE CONTROLLED LAWN ROBOT USING DYNAMIC MOVEMENT PRIMITIVES (DMP)</b> .....	171
<i>Adefemi Adeodu, Rendani Maladzi, Mukondeleli Grace Kana-kana, Ilesanmi Afolabi Daniyan and Kazeem Aderemi Bello</i>	
<b>INTRODUCTION</b> .....	172
Dynamic Movement Primitives .....	173
<b>SYSTEM ARCHITECTURE AND DESCRIPTION</b> .....	175
<b>SYSTEM DESIGN</b> .....	177
Design of Module for the Obstacle Avoidance .....	177
Module for the Hand Gesture Control .....	178
Gesture Extraction from Video Stream .....	178
Extraction of Region of Interest from the Frame .....	179
Determination of Gesture and Pattern Matching .....	180
Generation of Control Instruction for The Robot .....	180
Image Processing and Improvement .....	181
Image Colour Tracking Process .....	181
Performance Simulation .....	182
Discussion of Simulation Results .....	183
<b>CONCLUSION</b> .....	184
<b>REFERENCES</b> .....	184
<b>CHAPTER 13 EXPERIMENTAL DESIGN AND MODELLING OF AUTOMATED 4- CYLINDER ENGINE INJECTOR</b> .....	187
<i>Kazeem Aderemi Bello, Abdulrahman Adama, Olasunkanmi Adekunle Odunaiya and Cordelia Ochuole Omoyi</i>	
<b>INTRODUCTION</b> .....	188
<b>EXPERIMENTAL SET-UP</b> .....	189
<b>METHODS</b> .....	191
<b>THE MODELLING OF THE WORKING PRINCIPLE OF A 4-CYLINDER INJECTOR ENGINE</b> .....	192
<b>RESULT AND DISCUSSION</b> .....	192
<b>CONCLUSION</b> .....	195
<b>REFERENCES</b> .....	196
<b>SUBJECT INDEX</b> .....	3;;

## FOREWORD

The dynamics of consumer needs, as well as the need to ensure time and cost effectiveness of the manufacturing process without compromise to product's quality necessitate the development of robust automation and control strategies. With the advent of Industry 4.0, industries are looking for ways to achieve sustainability, cost efficiency, competitive advantages, productivity and profitability, economies of scale, scalability and flexibility, hence, the need for the automation of industrial systems and processes. The automation and control of industrial systems focus on the efficiency of industrial processes and organisation's profitability. This will also improve system's flexibility with a substantial improvement in the manufacturing processes, product quality, and a reduction in industrial errors.

This book presents recent and novel theoretical concepts and practical findings in the field of automation and control. It comprises thirteen chapters that delve into the principles of automation and control. Furthermore the following thematic areas were also covered: automated processes and systems, control theory, system's control, computer control devices, industrial automation tools, application of industrial automation as well as practical examples of how automation can be achieved in systems. Furthermore, empirical findings that highlight recent advances in the field of automation and control are discussed.

The book also discusses the performance of automated systems and controls and how such performances can be enhanced with relevant examples and case studies drawn from real world research. The book is multi-disciplinary in nature and it is designed for learners, experts, instructors, academics, engineers, and professionals whose field of interests match the niche area of automation and control.

The book disseminates knowledge critical for system's automation and control. The book provides entrepreneurs, experts and engineers meaningful insights into practical ways to achieve automated business solutions from the design level. Thus, this book demonstrates how simple or complex processes can be automated and controlled to deliver a sustainable business value.

With the knowledge and expertise of the contributing authors, my teaching and research acumen in manufacturing, automation and control was geared to provide novel contributions to this book. Some of the automation and control concepts presented in the book are still emerging and will be of a great benefit to the readers and experts in the quest to gain wide range of knowledge in the field of automation and control.

**Festus Fameso**  
Department of Mechanical and Automation Engineering  
Tshwane University of Technology  
Pretoria  
South Africa

## PREFACE

With the emerging technologies, the quest for competitiveness by organisations, dynamic nature of customer requirements and market demand, need to achieve product quality and organisation's bottom line; profitability in a time and cost effective manner, the role of automation and control cannot be overemphasised. There is a constant quest by organisations to achieve the development of smart systems for effective delivery, monitoring and control. Since manufacturing industries are profit-oriented and are concerned with the precision and productivity per worker of their plants, automatic systems offer the solution of high productivity and effective control without sacrificing precision and accuracy. Furthermore, the increasing complex nature of production or manufacturing systems requires engineers to have a proper understanding of the system's dynamics, behaviour and control requirements. This book bridges the gap between the theory and practice by providing and validating practical principles of automation and control. It provides a practical guided approach to help learners, professionals and organisations achieve automation and control of industrial systems. Besides it offers a robust technical data and theoretical principles relating to automation and control. The book contains twelve chapters which address many important aspects of automation and control including automation classes and principles, control theories, instrumentation, supervisory systems and robotics amongst others. It also unveils the basic and fundamental principles underlying the design of control systems.

The book is ideal for readers including learners, academics, professionals, technical personnel's *etc.* as an educational and instructional resource across multi-disciplinary fields such as electrical engineering, chemical engineering, mechanical engineering, electronic engineering, mechatronic engineering, computer engineering, system engineering and other related fields. It will help readers gain theoretical and practical knowledge of system's control and automation so that they can be experts in the fields.

**Ilesanmi Afolabi Daniyan**  
Department of Industrial Engineering  
Tshwane University of Technology  
Pretoria/2223  
South Africa

## **ACKNOWLEDGEMENTS**

I wish to appreciate God Almighty for the grace and privilege to serve as the editor of this book. I wish to thank my precious wife: Dr. (Mrs) Oluwatoyin Esther Daniyan for her invaluable support all the time. I appreciate God in the lives of my two wonderful Generals of God Almighty; Daniel and Samuel. Many thanks to all the authors who contributed their ideas and findings to this book and to all the reviewers who made time out of their busy schedules to ensure a thorough review process. My appreciation goes to Dr. Adefemi Adeodu, Dr. Boitumelo Ramatsetse and Dr. Festus Fameso for their professional contributions.

Thank you all.

## **DEDICATION**

This book is dedicated to God Almighty: Most Glorious, Most Magnificent, Immortal, Invisible and the Only Wise God.

## List of Contributors

<b>Abdulrahman Adama</b>	Department of Mechanical Engineering, Federal University Oye Ekit, Nigeria
<b>Adefemi Adeodu</b>	Department of Mechanical Engineering, University of South Africa, Florida, South Africa
<b>Bankole Oladapo</b>	School of Engineering and Sustainable Developmen, De Montfort University Leiceste, UK
<b>Boitumelo Ramatsetse</b>	Department of Mechanical & Mechatronics Engineering, University of Stellenbosch, Stellenbosch, South Africa
<b>Cordelia Ochuole Omoyi</b>	Department of Mechanical Engineering, University of Calabar, Calabar, Nigeria
<b>Fawaz A. Babajide</b>	Department of Mechanical & Mechatronic Engineering, Afe Babalola University, Ado Ekiti, Nigeria
<b>Felix Ale</b>	Department of Engineering & Space Systems, National Space Research & Development Agency, Abuja, Nigeria
<b>Ilesanmi Afolabi Daniyan</b>	Department of Industrial Engineering, Tshwane University of Technology, Pretoria 0001, South Africa
<b>Ikenna Uchegbu</b>	Department of Mechanical & Afe Babalola, Ado Ekiti Mechatronic Engineering, Afe Babalola, Ado Ekiti, Nigeria
<b>Ididiong Etudor</b>	Department of Mechanical Engineering, Afe Babalola Universit, Ado Ekiti, Nigeria
<b>Jacobs Kelechi</b>	Department of Mechanical & Mechatronic Engineering, Afe Babalola University of Nigeria, Ado Ekiti, Nigeria
<b>Kazeem Aderemi Bello</b>	Department of Mechanical Engineering, Federal University Oye Ekit, Nigeria
<b>Khumbulani Mpfungu</b>	Department of Industrial Engineering, Tshwane University of Technology, Pretoria 0001, South Africa
<b>Lanre Daniyan</b>	Department of Instrumentation, Centre for Basic Space Science, University of Nigeria, Nsukka, Nigeria
<b>Mukondeleli Grace Kana-kana</b>	Department of Industrial Engineering, Tshwane University of Technology, Pretoria 0001, South Africa
<b>Olasunkanmi Adekunle Odunaiya</b>	Department of Mechanical Engineering, Federal University Oye Ekit, Nigeria
<b>Osato Alexandra Ighodaro</b>	Department of Mechanical and Mechatronics, Afe Babalola University, Ado Ekiti, Nigeria
<b>Rendani Maladzhi</b>	Department of Mechanical Engineering, University of South Africa, Florida, South Africa
<b>Saheed Akande</b>	Department of Mechanical & Mechatronic Engineering, Afe Babalola University, Ado Ekiti, Nigeria
<b>Vincent Balogun</b>	Department of Mechanical Engineering, Afe Babalola University, Ado Ekiti, Nigeria



*vi*

**Wasiu Adeyemi Oke**

Department of Mechanical & Mechatronic Engineering, Afe Babalola  
University, Ado Ekiti, Nigeria

**CHAPTER 1****Introduction to the Principles of Automation and Control****Ilesanmi Afolabi Daniyan<sup>1,\*</sup>**<sup>1</sup> *Department of Industrial Engineering, Tshwane University of Technology, Pretoria 0001, South Africa*

This book disseminates information about the principles and concepts of automation and control. Nowadays, more industries continue to embrace automation technologies, with the increasing use of control systems. Automation technologies and control systems find application across virtually all sectors; manufacturing economy, military, construction, and cyber security amongst others. The deployment of automation technologies boasts operational health and safety, reduction in human exposure to hazardous materials or environments, operational efficiency, time effectiveness, increase in productivity, and improvement in product quality. With automation, human error can be eliminated while repetitive or monotonous tasks are assigned to automated systems. The challenge of workers' displacement can be addressed *via* human capacity development. The upskilling of workers is a longer-term investment that can augment the expertise, skills, knowledge, and competencies of workers to enable them to collaborate effectively with machines or to advance their careers. In terms of the high initial setup cost of automating technologies, the initial cost of automating systems and processes will be offset with an economy of scale. Hence, automation also boasts a cost advantage that industries can achieve by scaling their operations, as a function of the amount of output produced. This can result in a decrease in cost per unit of output with an increase in scale. However, the major challenge of automation is the displacement of workers *via* their replacement with machines and the high initial cost that may not be effective for small to medium-scale enterprises. Chapter one provides an overview of the book while Chapters 2 to 7 are dedicated to the theoretical concepts of automation and control. Chapters 8 to 13 present ground-breaking research on automation and control and provide empirical results from the application of automation and control.

\* **Corresponding author Ilesanmi Afolabi Daniyan:** Department of Industrial Engineering, Tshwane University of Technology, Pretoria 0001, South Africa; Tel: +27 (064) 5298778; E-mail: [afolabiilesanmi@yahoo.com](mailto:afolabiilesanmi@yahoo.com)

A control system is an integral part of automation. The control system provides a means of monitoring, and tracking system's performance and execution of changes in real-time to eliminate deviations from the ideal performance. Thus control systems assist in obtaining good systems output through real-time monitoring and control. This makes many industrial processes effective and productive. This book comprises thirteen chapters that investigate the principles of automation and control.

Chapter 2 of this book presents the general introduction and definition of the basic concepts underlying automation and control. It differentiates between mechanization and automation and draws a correlation between automation and artificial intelligence. Also, the capabilities underlying AI technology are also highlighted. Furthermore, the classes of automation are explained including the procedures for automation design. The chapter ends with the merits and demerits of automation.

Chapter 3 deals with the automated processes and systems and explains the elements of system's automation. It delves into the systems operations, programming and classes of automated systems. The Programmable Logic Controller (PLC) mostly adapted for manufacturing process controls in machines, robots and assembly lines due to its merits of high reliability, ease of programming, and process fault diagnosis is also explained. The two major classes of the control system; open and closed loop control systems otherwise known as the non-feedback controls and feedback control systems respectively are discussed including their designs.

Chapter 4 discusses the levels of automation which could range from manual, semi-automatic to fully automatic depending on the level of human involvement. Furthermore, the elements of system's automation and classes of automated systems are highlighted. The identification and specifications of the elements of system's automation based on the end-user requirements are a critical aspect of the control design phase. The major elements of the system's automation include the sensor, controller, actuator, power component, motor and drives, communication protocol, human-machine interface, *etc.* Classes of automation systems could also be fixed, programmable, flexible, integrated or cognitive automation depending on the need.

Chapter 5 presents the control system and its functions, types, examples and representation of the process control systems. The chapter also discusses the types of variables: controlled, manipulated and disturbance variables. Furthermore, the types of system's processes such as batch, continuous and individual processing are explained. The chapter concludes with the Proportional-Integral-Derivative (PID) controller as a basic form of control. A PID controller is a control

instrument used in industrial control applications to regulate process variables such as temperature, pressure, flow, speed, *etc.* A PID controller employs a control loop feedback mechanism to control process variables to achieve stability of the controlled variable.

Chapter 6 deals with the control devices in automation such as Programmable Logic Devices (PLD), PLC, PAC, PC *etc.* The sensors feed the main controller with the input data acquired from the environment. Following the processing of the data, a decision is made by the main controller on the control action to take and this decision is communicated to the control devices for execution.

Basically, the control devices include the input devices (for raw data input), processing devices (for processing raw data into information), output devices (to disseminate the processed data and information) and storage devices (for retention of processed data and information). The chapter concludes by differentiating between a controller and an actuator.

In Chapter 7, the emphasis is on the industrial automation tools and components. The different types of industrial automation tools such as Artificial Neural Networks (ANN), Distributed Control Systems (DCS), Human-Machine Interface (MHI), Supervisory Control and Data Acquisition Systems (SCADA), instrumentation, and robotics were highlighted. Furthermore, the application of industrial automation in robotics, packaging systems, computer numeric control systems, tool monitoring systems, advanced inspection systems as well as flexible manufacturing systems are discussed.

Chapter 8 provides practical examples of system's automation. Some specific examples presented include: the automation of irrigation system, waste segregator, gasifiers, biodiesel plants, biogas plants, lawn mowers, assembly line automation as well as control and automation of railcar suspension system. The details of the design and components required for the automation of these systems are highlighted.

Chapter 9 presents a practical example of water distribution management in real time using a cloud based approach. The chapter presents the computer aided design of the proposed system as well as the materials and method necessary for achieving automation and control of this system. The performance evaluation of the developed system is discussed and the results obtained are presented.

Chapter 10 presents the automation of a waste segregator. The chapter discusses the material and method necessary for the development and implementation of an automated waste segregator including the assembly and software phases. The

**CHAPTER 2****Concepts of Automation and Control****Ilesanmi Afolabi Daniyan<sup>1,\*</sup>, Lanre Daniyan<sup>2</sup>, Adefemi Adeodu<sup>3</sup> and Khumbulani Mpofu<sup>1</sup>**<sup>1</sup> *Department of Industrial Engineering, Tshwane University of Technology, Pretoria 0001, South Africa*<sup>2</sup> *Department of Instrumentation, Centre for Basic Space Science, University of Nigeria, Nsukka, Nigeria*<sup>3</sup> *Department of Mechanical Engineering, University of South Africa, Florida, South Africa*

**Abstract:** The discussion in this chapter revolves around the general introduction and the basic definition of the concepts of automation and control. Automation and control are closely interrelated fields with the advent of Industry 4.0. Automation deals with the integration of technologies that can enable systems to carry out tasks without human intervention or with minimal intervention. On the other hand, control is a process of monitoring and manipulating the variables of a system in order to achieve the desired outputs. Hence, an automated system comprises the control system, information, communication and technology system, actuator, and effective feedback mechanism. The emergence of Industry 4.0 technologies focuses on improvement in efficiency, profitability, systems' flexibility, manufacturing processes, product quality, cost, and time effectiveness with a significant reduction in manufacturing process errors. These improvements can be aided by putting in place a system with effective automation and control. This chapter further explores the differences between mechanization and automation and draws a correlation between automation and artificial intelligence. Also, the capabilities underlying the Artificial Intelligence (AI) technology are highlighted. Furthermore, the classes of automation are explained including the procedures for automation design. In addition, the merits and demerits of automation are highlighted and the chapter ends with the automation of production lines and different work layout configurations. The concept of automation is central to industrial society and is prevalent in the engineering industries (manufacturing, process industries, *etc.*).

**Keywords:** Artificial Intelligence, Automation, Control, Industry 4.0.

**GENERAL INTRODUCTION AND DEFINITION OF BASIC CONCEPTS**

The word “automation” is derived from the Greek words “Auto” (self) and “Matos” (moving). Therefore, automation means the development of a mecha-

---

\* **Corresponding author Ilesanmi Afolabi Daniyan:** Department of Industrial Engineering, Tshwane University of Technology, Pretoria 0001, South Africa; Tel: +27 (064) 5298778; E-mail: [afolabiilesanmi@yahoo.com](mailto:afolabiilesanmi@yahoo.com)

nism for systems to operate by themselves. Hence, systems are automated to move, adjust and implement instructions by themselves. It is a technological method by which a process or system is controlled with the use of electronic, mechanical and computer-based instructions without human intervention [1]. It could also be defined as a set of technologies integrated to enhance machine independence during operation without significant human intervention or the application of machines to tasks once performed by human beings or, to tasks that would otherwise be impossible to perform by humans [1].

The control of a process or system by automatic means rather than manual is often called automation. It comprises a set of technologies by which simple or complex processes or systems can be operated independently or with little human intervention. The set of technologies are integrated into a self-governing system for the execution of a particular task. Systems are automated to minimise their interactions or dependencies on human personnel [2]. A control system is a set of technologies used to adjust the process parameters to achieve the desired output. Therefore, through effective control, the desired output of a system can be achieved by adjusting or regulating the input variables [3]. Hence, automation and control refer to the collection of personnel, hardware and software employed to ensure effective monitoring, precision and accuracy, safety, security, efficiency, productivity and reliability of the manufacturing or industrial process [4]. The automation systems encompass the control system, information, communication and technology system, actuator and effective feedback mechanism.

The concept of automation is central to industrial society and is prevalent in the engineering industries (manufacturing, process industries, *etc.*). To reduce the rising wages and its associated production cost, automatic machines are employed to increase the production of a plant per worker. Manufacturing industries are profit-oriented and are concerned with the precision and productivity per worker of their plants. Automatic systems offer the solution of high productivity without sacrificing precision and accuracy [4]. Hence, the reduction of human interference in the operation of machines and direct replacement by technologically driven systems, such as computers, robots *etc.* is referred to as automation.

The performance of automated systems in terms of accuracy, precision, speed of operation, and productivity, is usually superior when compared to manual systems. Automation covers a broad range of applications ranging from simple systems such as household devices to complex industrial systems. For large and complex systems, there are thousands of input variables and output signals which are measured and controlled autonomously to enhance the system's independence. The control may be in the form of a simple ON/OFF control to complex or multi-

variable high-level algorithms. Industrial automation utilizes control systems as well as information technologies to handle different processes and machinery in the industries. Automation has helped in improving production quality and quantity, thus, making production lines much more flexible. The technology can be deployed for material handling operations, assembly, production, machining, transportation, inspection, quality assurance and packaging amongst others [5]. A robust automation system often entails control technologies, artificial intelligence, enabling communication protocols, and hardware sections. This will assist manufacturing industries to gain a competitive edge, ensure production system's reliability and promote high production efficiency. It will also assist in meeting the challenges of the increasing dynamics and complexities of manufacturing and product development. Automation and control are terms often used together or interchangeably. Control involves the operation or adjustment of devices or components in order to ensure that the system does not deviate from the set or desired points. These adjustments are done with the aid of control systems, devices or actuators. Common examples include the turning ON and OFF of light and the use of the press button of wireless remote controls. Many other systems in and outdoors also possess devices for effective control such as indoor and outdoor lighting systems, air condition systems, television, cooking and refrigeration system. The elements of control and actuators are a subset of automation. On the other hand, the process of automation integrates many control devices with effective interaction to carry out many tasks independently with a centralized intelligent control system that responds to input signals in order to control each of the control devices. With the integration of many control devices controlled centrally with an intelligent control system, the overall system can be programmed to run with the least human intervention. The branch of engineering which uses programmable machines to automate activities is referred to as robotics. The programmable machines are called robots. Depending on the system's requirements and the level of automation, robots can operate autonomously or semi-autonomously. They are designed to interact and interface with the physical world with the aid of sensors, cameras and actuators with good learning and perception abilities of the environment. The ones that are reprogrammable are flexible enough to permit dynamic changes and robots can be collaborative in nature permitting activities to be carried out with humans at the same time. Automation can be achieved with the combination of mechanical, electro-mechanical, electrical, and electronic devices, computer and computer programs, as well as pneumatic and hydraulic systems.

## **MECHANIZATION AND AUTOMATION**

In the scope of industrialization, automation is beyond mechanization. While mechanization is a vital component of industrialization replacing human drudgery

## Automated Processes and Systems

Saheed Akande<sup>1,\*</sup>, Wasiu Adeyemi Oke<sup>1</sup> and Fawaz Aremu Babajide<sup>1</sup>

<sup>1</sup> Department of Mechanical & Mechatronic Engineering, Afe Babalola University, Ado Ekiti, Nigeria

**Abstract:** In this chapter, the concepts of automated processes and systems including the elements of system automation are explained. In process automation, digital technologies are often used to automate complex manufacturing or business processes. This includes the use of the system to perform tasks and the integration of software, information and communication technology, data acquisition, and storage sub-systems. A system may go through several processes that are time sensitive and repetitive before obtaining the final output. Process automation prevents variation and bottlenecks associated with these processes such as errors, and data loss while improving speed and communication among other sub-systems. System automation is a subset of Mechatronics engineering that involves the integration of a sensing system, control mechanisms, and drive system (actuators). The three basic elements of an automation system that must be synergized include: the power system, the program of instructions or codes to direct the process, and the control mechanism to actuate the instructions. This chapter also delves into the systems operations, programming and classes of automated systems. The two major classes of the control system; open and closed loop control systems otherwise known as the non-feedback and feedback control systems respectively are discussed including their designs. The Proportional Integral Derivative (PID) controllers will continue to be important in several industrial applications because they utilize a control loop feedback mechanism to control process variables and are highly stable and accurate in achieving control tasks.

**Keywords:** Automated processes, control system, PID, system automation.

### INTRODUCTION

Automated solutions are increasingly used in the manufacturing industries because they can be deployed to replace slow manual processes in order to achieve production systems with higher efficiency. The streamlining of processes, workflows, and management of complex manufacturing technologies can also be achieved via automation. This chapter discusses the control system automation, classes of automation, basic controls, and the control system in general.

---

\* **Corresponding author Saheed Akande:** Department of Mechanical & Mechatronic Engineering, Afe Babalola University, Ado Ekiti, Nigeria; Tel: +2348061231291; E-mail: sakande1@abuad.edu.ng



## AUTOMATION PROCESSES

The word ‘Automation’ is derived from the Greek word “Auto” which means self and “Matos” which means motion. Automation is a technology that involves the application of mechanical, electrical, electronics, computer hardware, and software systems to operate, control and guide production processes and systems without significant human intervention and achieves performance significantly better than manual operation [1]. It is a subset of Mechatronics Engineering. Automations are widely used in almost all phases of production, industrial, business as well as the domestic world [2]. The application of automated systems and processes is unlimited ranging from domestic vacuum cleaner (domestic robot) to sophisticated machine assembling plant, automatic inspection system, and an industrial robot that operates in environments not suitable for human beings like high-temperature furnaces, and high-frequency electromagnetic waves (like gamma rays and X-rays) environments. Also, in the banking and business world, the use of automation is inevitable. Automated Teller Machine (ATM), and automatic money counter with fake note detectors among others are typical applications of automation systems.

### ELEMENTS OF SYSTEM AUTOMATION

System automation is a subset of Mechatronics engineering and it involves the integration of sensing systems, control systems, and drive systems (actuators). The three basic elements of an automation system [3] are:

1. The power to accomplish the process and operate the system.
2. A program of instructions (code) to direct the process,
3. A control mechanism to actuate the instructions.

The relationship between these elements is illustrated in Fig. (1).

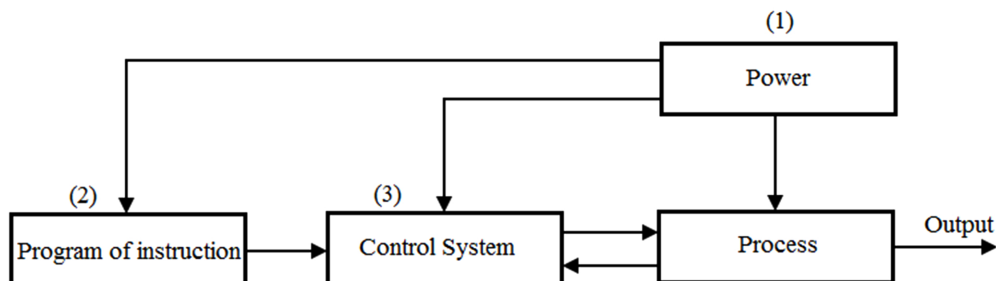

Fig. (1). Relationship among the elements of system automation.

## **THE POWER TO ACCOMPLISH THE PROCESS AND OPERATE THE SYSTEM**

The output of the automation system is motion or action. Thus, energy is required. Fundamentally, the energy expended per unit of time is power. Therefore, power is also required in an automation system. Just like different types of energies are available, power is also of different forms. Electrical power is the most commonly used form of power to operate automation systems due to its availability, cost, and ease of conversion to other forms like mechanical, heat, and light energy among others. The two main functions of power as an element of automation are: the accomplishment of the automation process and the operation of the automation system [4]. Electrical powers at low levels are required for the accomplishment of automation processes like signal transmission, information processing, data storage, and communication [5].

The output of the automation system (motion) performs two major functions;

- i. Processing: These include shaping, molding, loading, and unloading activities. Energy is applied to accomplish processing operations on some entity and thus power is required to convert the entity from one state into more required and valuable forms.
- ii. Transfer and position: This involves the moving of the product from one location to another during the series of processing steps, the positioning and placements of the products for processing, *etc.*

## **PROGRAM OF INSTRUCTIONS**

This is a set of commands that specify and define the sequence of steps or actions to be performed in an automation system. It is the foundation and the heart of an automation system [6]. A common example of a program of instruction as an element of automation is the use of Computer Numerical Control (CNC) for automating machine tools movements that control auxiliary functions including spindle through the use of software (code) embedded in the microcomputer attached to the tool [7]. The program written in an international standard language called G-code contains the instructions and parameters the machine tool will follow [8]. Milling, laser cutting, and lathe among others are common machine tools that can be automated with CNC. Some non-machine tools' operations like welding, assembly, and disassembly can also be automated on CNC. Each operation has a custom computer program, usually stored and executed by the Machine Control Unit (MCU). Other examples of the program of instruction include the temperature setting of a furnace, the ON and OFF of an electric motor, the use of an automated Universal Testing Machine (UTM), *etc.*

## Levels of Automation

Ilesanmi Afolabi Daniyan<sup>1,\*</sup>, Lanre Daniyan<sup>2</sup>, Adefemi Adeodu<sup>3</sup> and Ikenna Uchegbu<sup>4</sup>

<sup>1</sup> Department of Industrial Engineering, Tshwane University of Technology, Pretoria0001, South Africa

<sup>2</sup> Department of Instrumentation, Centre for Basic Space Science, University of Nigeria, Nsukka, Nigeria

<sup>3</sup> Department of Mechanical Engineering, University of South Africa, Florida, South Africa

<sup>4</sup> Department of Mechanical & Mechatronic Engineering, Afe Babalola, Ado Ekiti, Nigeria

**Abstract:** This chapter discusses the levels of automation (LOA). The degree to which a system, process or task is automated is referred to as the level of automation. They are: manual, semi-automatic and fully automatic depending on the level of human involvement, the system or processes to be automated and the end users' requirements. At the lowest level; the manual represents the human control level while the fully automatic level represents the computer controls level. At the semi-automatic level, the control activities involve both human and computer controls. The human control tasks include sensory processing for information acquisition, perception for information analysis, decision-making based on cognitive processing for action selection, and response selection for action implementation. Furthermore, this chapter also highlights the elements of system automation and classes of automated systems. The identification and specifications of the elements of the system's automation based on the end-user requirements are a critical aspect of the control design phase. The major elements of the system's automation include a sensor, a controller, an actuator, a power component, a motor and drives, a communication protocol, a human-machine interface, *etc.* Classes of automation systems could also be fixed, programmable, flexible, integrated, or cognitive automation depending on the need. The future of fully autonomous systems is exciting and promising although many industrial processes and systems are semi-autonomous thus relying on human factors such as physical, mental and technical capabilities such as intuition, perception, sensitivity, observation, experience, and judgment to arrive at effective decision making as it relates to system's control.

**Keywords:** Computer control, human control, LOA, system automation.

---

\* Corresponding author Ilesanmi Afolabi Daniyan: Department of Industrial Engineering, Tshwane University of Technology, Pretoria 0001, South Africa; Tel: +27 (064) 5298778; E-mail: afolabiilesanmi@yahoo.com

## INTRODUCTION

The level of automation in a system or process is the degree of human or computer controls employed for a particular operation which ranges from direct manual control to fully automated controls [1]. The levels of automation are defined as a continuum from a manual mode of operation to a fully automatic mode [2]. This refers to the number of manning levels that focus on the level of information sharing between machines and humans with varying degrees of human involvement [3, 4]. Levels of automation also refer to cognitive activities such as the system's ability to respond to changes and make decisions independently [5]. There are many activities that characterize process control, manufacturing and automation processes such as data collection, actuation, monitoring, decision-making, and control implementation amongst others. These can be performed independently or collaboratively by human or computer controls. Hoffman *et al.* [6] underscore the need for collaborative human or computer control during operation. This is due to the fact that both human and computer controls have distinctive merits and as such could compensate for the weaknesses inherent in either if employed collaboratively (Table 1).

**Table 1. Merits of the human and computer controls [6].**

Human control	Computer (Machine) control
Inductive reasoning.	Deductive reasoning.
Ability to make decisions and exercise judgment.	Quick control and response to changes and signals.
Flexibility and ability to improvise.	Ability to perform routine and repetitive activities.
Effective perception of the work environment and working conditions such as light, sound, noise, temperature, <i>etc.</i>	Large information storage, processing and computational capacities.
Ability to detect a small amount of acoustic or visual energy.	Ability to multi-task and effectively handle complex operations.

Hence, Satchell [7] stated that man-machine integration can be a suitable for task sharing and control.

## AUTOMATION LEVELS

Depending on the level of human intervention involved, the process of automation may be manual, semi-automatic, and fully automatic [3, 8-10]. A decision needs to be taken on the process of achieving vital production processes involving material handling, assembly, performance evaluation, trouble shooting, inspection and quality control feedback, data collection and decision making. These production processes can be achieved by manual, automated or semi-automated

means. The automation process, however, depends largely on the size and type of industry, the nature of product, product complexity, environment, manufacturing structure, and the efficiency required amongst other factors [11, 12].

### **Manual Level**

The manual level relies solely on human intelligence and effort to control, adjust or modify the operations of a system. It has the merits of flexibility, cost-effectiveness and is mostly suitable for small-scale industries with light equipment and simple operations or products that require a short production cycle. The demerits, however, lie in the low speed of production which increases production time, poor handling, and lower efficiency due to stress and fatigue when compared to automatic means and most times not suitable for production with heavy equipment and complex products as well as a product requiring reproducibility.

### **Semi-Automatic Level**

This level utilizes the combination of both human and computer controls or artificial intelligence for control. Thus, it represents a flexible mix of manual and automated tasks which is relatively flexible to accommodate some changes during the course of production. Computer control systems offer sets or a restricted set of alternatives regarding process conditions that humans have to make decisions about and implement. Its overall efficiency and delivery are greater than the manual process but lower than the fully automatic process.

### **Fully Automatic Level**

This level relies solely on computer algorithms and artificial intelligence for control. At this level, the control is executed solely by the computer. The control system acquires information, analyzes and displays the information acquired, and further decides on the necessary actions based on the outcome of the analysis and implements the actions based on the decision. The control system performs the tasks of data acquisition, process tracking, monitoring, provision of alternatives, monitoring, supervisory control and reporting. They are costly but highly efficient and can carry out simple as well as complex industrial operations with a high degree of precision and accuracy within a short time. The pace of production delivery with high precision will eventually offset the high initial cost. This process is inflexible to accommodate interchangeability or process deviation that is not programmed from the onset. Its lack of flexibility makes it catastrophic when there are challenges along production routes or in automatic mode. Fully automatic level boasts of high speed of production within a short production

## The Control System

Ilesanmi Afolabi Daniyan<sup>1,\*</sup>, Lanre Daniyan<sup>2</sup>, Boitumelo Ramatsetse<sup>3</sup> and Khumbulani Mpofu<sup>1</sup>

<sup>1</sup> Department of Industrial Engineering, Tshwane University of Technology, Pretoria 0001, South Africa

<sup>2</sup> Department of Instrumentation, Centre for Basic Space Science, University of Nigeria, Nsukka, Nigeria

<sup>3</sup> Department of Mechanical & Mechatronics Engineering, University of Stellenbosch, Stellenbosch, South Africa

**Abstract:** This chapter presents the control system and its functions, types, examples, and representation of the process control systems. A control system is a system that regulates, directs, commands, and manages the performance of other sub-systems using a control loop. Basically, there are two major types of control systems, viz; the open and closed loop control systems. For the open loop control system, control action is independent of the desired output. This control system is referred to as a non-feedback control because of the absence of a feedback path. Although they are simple in design and relatively inexpensive but are less accurate compared to the closed-loop control system. On the other hand, for the closed-loop control system, control action is a function of the desired output. This control system is referred to as feedback control because of the presence of the feedback path. Although it is complex in design and expensive but more accurate compared to the open loop control system. To enhance the performance of basic controls, many modern systems incorporate advanced controls such as advanced regulatory controls, advanced process controls, multivariable predictive control, non-linear multivariable predictive control, fuzzy logic control, inferential measurements, *etc.* Advanced controls are a set of technologies employed to address a specific control deficiency in a system. While the basic controls facilitate the control of a system's basic operations, advanced controls are incorporated to enhance the performance of the basic controls.

**Keywords:** Basic control, Control system, Advanced control, Open loop system, Closed loop system.

### INTRODUCTION

Production can be a challenging task amidst process or system variations, dynamic demand, and customer requirements if the production system is not

---

\* Corresponding author Ilesanmi Afolabi Daniyan: Department of Industrial Engineering, Tshwane University of Technology, Pretoria 0001, South Africa; Tel: +27 (064) 5298778; E-mail: afolabiilesanmi@yahoo.com

effectively controlled. To deliver products with the right quality that will meet the production or demand requirements, the production system must be controlled to minimize errors and deviation. This chapter discusses the types of control systems and their functions, the types of system processes and the general control theory.

## THE CONTROL SYSTEM

A control is a device used to manipulate the performance of a system. It is a term that can be used to describe the process of altering the behavior of a system or keeping the behavior constant over time. The alteration can be done either manually or automatically. This implies that controls can be done manually or automatically depending on the nature of the system. The system executes and monitors an industrial operation, taking corrective measures when there is a deviation from the set points. A control system can be defined as the collection of components that are designed to drive a given system from a particular input to the desired output. In other words, it is an interconnection of components including additional hardware that forms a system configuration to control the behavior of a dynamic system in order to obtain the desired system response.

## FUNCTIONS OF THE CONTROL SYSTEM

The main function of a control system is to ensure that the outputs of a system do not deviate from the set or desired points [1, 2]. A good control system should effectively manage the instructions, direct and regulate the behaviour of a system or a system sub-component. Control systems are incorporated into the system for the following reasons [3]:

1. To obtain data (*via* direct measurement or acquisition): Data can be obtained *via* direct measurement of values from sensors which are read as input to process or provide signals as output. For instance, a sensor is a device for measuring physical quantities such as speed, temperature, pressure, velocity, *etc.* On the other hand, data can also be obtained *via* the acquisition of past activities.
2. To compare: This involves the dynamic comparison of the operations and conditions to the desired set points in real-time. This is to evaluate the measured value and the process value *vis-à-vis* the threshold. For instance, transducers are comparators that convert the non-electrical signal into an electrical value.
3. To compute: Control systems can be used to calculate the errors in a process or system. Error is the difference between the desired and true output signals. For instance, a transmitter can convert measurements from a sensor and send the signal to the main controller. The difference between the actual measurement and

the threshold value pre-set on the microcontroller represents the error generated.

4. To regulate: Systems are regulated, controlled, or corrected to alter the course of the operations or the process conditions to the desired set points. This is usually to curb the effect of error generated or external disturbances. They are also regulated to keep operating variables or output within the desired range. For instance, a controller provides logic for the process while the final control element also known as the actuator changes the process physically.

5. To track: Tracking is carried out to enable process variables or output to follow a particular changing form. It involves keeping the profiles of a series of operations and conditions.

Hence, the process of obtaining data, data comparison with the threshold, regulation of the course of operation, and tracking is what is referred to as the control actions of a control system.

## **TYPES OF CONTROL ACTIONS**

There are two major types of control actions in a system namely discrete otherwise known as precise control and continuous control [2].

### **Discrete Control**

The discrete control can be in the form of a simple binary ON/OFF control or a more advanced modulating control which is suitable when a sequential control of such a system is required. In discrete control, the system's variables are changed at discrete moments in time. The changes are implemented because of event-driven changes (changes in the state of the system) or because of time-driven changes (changes due to the fact that the specified amount of time has lapsed).

An event-driven change is usually executed by the controller as a response to a certain event that alters the state of the system. This change can be to initiate or terminate an operation, for instance, starting or shutting off a motor, opening and closing a valve, fuel tank used in a boiler-based power, the thermostat used on household appliances which either opens or closes an electrical contact plant, *etc.*

For a time-driven change, the control system implements control at a specified time or after a specified time has elapsed, for instance, heat treatment operations, automatic loading, and unloading of parts, the operation of a washing machine, *etc.*

A modulating control is an automated control, which is employed to regulate the amount of flow in the process. The control allows precise regulation of the flow



**CHAPTER 6****Computer Control Devices in Automation****Ilesanmi Afolabi Daniyan<sup>1,\*</sup>, Lanre Daniyan<sup>2</sup>, Adefemi Adeodu<sup>3</sup> and Felix Ale<sup>4</sup>**<sup>1</sup> *Department of Industrial Engineering, Tshwane University of Technology, Pretoria 0001, South Africa*<sup>2</sup> *Department of Instrumentation, Centre for Basic Space Science, University of Nigeria, Nsukka, Nigeria*<sup>3</sup> *Department of Mechanical Engineering, University of South Africa, Florida, South Africa*<sup>4</sup> *Department of Engineering & Space Systems, National Space Research & Development Agency, Abuja, Nigeria*

**Abstract:** This chapter deals with the control devices used in automation such as Programmable Logic Devices (PLD), Programmable Logic Controller (PLC), Programmable Automation Controller (PAC), Personal Computer (PC), *etc.* The goal of the control devices in automation is to achieve an efficient, robust and reliable system control. Basically, system control devices include input devices (for raw data input), processing devices (for processing raw data into information), output devices (to disseminate the processed data and information), and storage devices (for the retention of processed data and information). The sensors feed the main controller with the input data acquired from the environment. Following the processing of the data, the decision is made by the main controller on the control action to take and this decision is communicated to the actuator for execution. The actuator in turn drives the final control device to implement the control action. The programming language is crucial in achieving optimum efficiency. While the PLC follows a scan-based program execution, PC software is usually event-driven. In terms of cost efficiency, indicators such as performance, expandability, and ruggedness are important considerations. The initial cost of a PC may be higher than that of a PLC as a PC is more suitable for processing of complex network loads. PLC may be initially inexpensive but as the demand for processing power increases, the PC-based system becomes more cost-effective. In terms of expandability, PLC usually offers support to standard industrial equipment but when an external control is needed, a PC is more suited. PLC does not require additional protection equipment compared to PC.

**Keywords:** PAC, PC, PLC, PLD.

---

\* **Corresponding author Ilesanmi Afolabi Daniyan:** Department of Industrial Engineering, Tshwane University of Technology, Pretoria 0001, South Africa; Tel: +27 (064) 5298778; E-mail: [afolabiilesanmi@yahoo.com](mailto:afolabiilesanmi@yahoo.com)

## **INTRODUCTION**

Control devices are output devices that use input signals from sensors to change the state of a system or process. They can be in the form of mechanical, electronic or electro-mechanical devices and ranges from simple devices having a single loop such as a pump control to a sophisticated control such as the PLC having multiple inputs and outputs for full industrial automation. Unlike the single-loop controls, multi-loop controls can receive data from more than one sensor and provide control functions to more than one device.

## **PROGRAMMABLE LOGIC DEVICES (PLD)**

Programmable Logic Devices (PLD) are integrated circuits that are programmed to perform different control functions according to the programs written in their memory. They usually employ low-level languages of commands and find applications in manufacturing automation. They consist of an array of the AND as well as the OR gates and the development software can be used to convert the basic codes into sets of instructions that a programmer can employ to implement the logic design.

The types of PLD types are classified as follows [1].

1. PROMs (Programmable Read Only Memory). This class offers high speed and low cost and it is suitable for relatively small designs.
2. PLAs (Programmable Logic Array): This class offers more flexible features which make it more suitable for complex designs.
3. PAL/GALs (Programmable Array Logic/Generic Array Logic): For this class, the random-logic gate networks are compactly laid out on an IC chip. This class offers good flexibility and speed and are less expensive than the PLAs.

The PLDs have several advantages and disadvantages depending on the type used.

For instance, the PLAs, like ROMs have the following advantages over PAL/GALs.

1. The design is not time-consuming compared to the PAL/GALs, characterized by time-consuming logic design of random-logic gate networks and an even more time-consuming layout.
2. The design is easy and flexible.

3. Quick and easy adoption of emerging technologies without the need for a change in the previous information.
3. Random-logic gate networks occupy smaller chip areas than PLAs or ROMs, although the logic design and the layout of random-logic gate networks are far more tedious and time-consuming.
4. Also, with large production volumes, random-logic gate networks are cheaper than PLAs or ROMs.

Compared to the ROMs, the PLAs have the following advantages. PLAs are smaller in size than the ROMs; this brings about a reduction in the board space requirement, and power requirement with improved compact circuitry. The disadvantage is that the merit of the small size of PLAs fizzles out as the number of terms in a disjunctive form increases. Thus, PLAs cannot store complex functions, most especially functions whose disjunctive forms consist of many product terms.

#### **APPLICATIONS OF PLAS AND PAL/GALS**

A micro-processor chip uses many PLAs because of the ease of design and flexibility. PLAs find applications in control logic and systems in which flexibility is a requirement. PLAs are used for code and micro-programs conversions, bus priority resolvers, decision tables and memory overlay.

PLA is also suitable for use when a new product is to be manufactured in small volume or as a test prototype due to the need for changes in the product at such stage. For a mature product that requires no further changes, the PLAs can be replaced by the random-logic gate networks for cost-effectiveness, volume production, and high speed.

A typical programmable machine has basic three components namely; a processor, memory as well as input and output devices.

#### **Processor**

This processes the information collected from the measurement system and takes logical decisions based on the information. The information is thereafter sent to the actuators or output devices.

#### **Memory**

The memory stores the input data collected from sensors and the programs to process the information in order to take necessary decisions or actions. A program

**CHAPTER 7****Industrial Automation Tools and Components****Ilesanmi Afolabi Daniyan<sup>1,\*</sup>, Lanre Daniyan<sup>2</sup>, Felix Ale<sup>3</sup> and Khumbulani Mpofu<sup>1</sup>**<sup>1</sup> *Department of Industrial Engineering, Tshwane University of Technology, Pretoria 0001, South Africa*<sup>2</sup> *Department of Instrumentation, Centre for Basic Space Science, University of Nigeria, Nsukka, Nigeria*<sup>3</sup> *Department of Engineering & Space Systems, National Space Research & Development Agency, Abuja, Nigeria*

**Abstract:** Industrial automation tools are of a wide range of tools that are employed for industrial automation. These tools comprise various control systems that incorporate diverse sub-systems or devices to enhance industrial processes. Notable examples include Computer-aided design (CAD software) and Computer-aided manufacturing (CAM software), Artificial Neural Networks (ANN), Distributed Control Systems (DCS), Human-Machine Interface (HMI), Supervisory Control and Data Acquisition System (SCADA), instrumentation and robotics, *etc.* They are beneficiaries in the area of product development (improved design, analysis, and manufacture of products), quality control time and cost-effectiveness amongst others. This chapter emphasizes industrial automation tools and components. Furthermore, the application of industrial automation in robotics, packaging systems, computer numeric control systems, tool monitoring systems, advanced inspection systems as well as flexible manufacturing systems were discussed in this chapter. Industrial automation tools can significantly influence industrial processes with a reduction in manufacturing lead time, improvement in product quality, and effective process monitoring.

**Keywords:** ANN, Automation tools, CAD, CAM, DCS, HMI, SCADA.

**INTRODUCTION**

Industrial automation tools are tools that can be used to achieve process, system or industrial automation. They assist in creating mechanical or digital channels to solve manufacturing problems. These tools can also assist in achieving production efficiency as well as significant cost and time savings. This chapter discusses the types of industrial automation tools and their applications.

---

\* **Corresponding author Ilesanmi Afolabi Daniyan:** Department of Industrial Engineering, Tshwane University of Technology, Pretoria 0001, South Africa; Tel: +27 (064) 5298778; E-mail: [afolabiilesanmi@yahoo.com](mailto:afolabiilesanmi@yahoo.com)

## **TYPES OF INDUSTRIAL AUTOMATION TOOL**

The following are the types of industrial automation tools;

1. The Artificial Neural Network (ANN)
2. The Distributed Control System (DCS)
3. The Human Machine Interface (HMI)
4. Supervisory Control and Data Acquisition (SCADA)
5. Programmable Logic Controller (PLC)
6. Instrumentation
7. Motion control
8. Robotics

### **The Artificial Neural Network (ANN)**

An artificial neural network is a mathematical or computational model whose behaviour mimics those of biological neurons. The structure of the ANN is adaptive, as it can change based on the external or internal exchange of information within the network. Artificial neural networks are used to study, identify and correlate patterns in pools of data and to classify relationships (such as sequence recognition). Applications include e-mail spam filtering, system control (such as in a car), an automated irrigation system, pattern recognition in systems such as radars, pattern recognition in speech, movement, and text, and financial automated trading systems.

### **The Distributed Control System (DCS)**

A distributed control system is the one that comprises separate controls throughout the system. The controls are not centrally located, but tend to be in the parts of the system that needs monitoring with each control connected to the others in a communication network. These kinds of systems are typically used in continuous manufacturing processes. For a given process, the controllers can be specified and manipulated to enhance or monitor machine performance. The distributed control system finds application in oil refining and central station power generation as well as in robotic operations. For instance, the traffic lights are usually controlled by a distributed control system.

## **Human-Machine Interfaces (HMI)**

Human-machine interfaces (HMI) or computer human interfaces (CHI) are usually used to communicate with PLCs and other computers [1]. A human machine interface system depends on human interaction with the system in order to function with the user who will provide the input while the output that coincides with the user's intent will be produced by the system. For example, the automated teller machine (ATM) is designed so users can easily manipulate the system thereby providing the appropriate results. The buttons on the machine provide the user an avenue to trigger a chain of commands within the internal system.

## **Supervisory Control and Data Acquisition System (SCADA)**

A supervisory control and data acquisition system (SCADA) is a larger, industrial control network often comprising smaller sub-systems, including human machine interface systems that are connected to remote terminal units. The system translate sensor signals into a comprehensible data and the SCADA system can effectively control an entire manufacturing site, by linking up the different manufacturing plants in the site [2]. The term SCADA is normally associated with the development of control systems that cover a large geographic area. A SCADA is used for centralized monitoring and control of field sites over long-distance communication networks with the field devices employed for local operations such as the collection of data from sensor, opening and closing of valves and breakers, as well as the monitoring of the entire environment. SCADA systems are similar to distributed control systems, and the key difference lies in their function. SCADA systems do not control each process in real time, rather they coordinate processes.

## **Instrumentation**

Instrumentation refers to the collection of instruments used for indicating, measuring, and recording physical quantities [1]. It also refers to the ability to monitor or measure the level of a product's performance, to diagnose errors in order to rectify them where necessary. The operation of measuring instruments is used in the design and configuration of automated systems in electrical, hydraulic and pneumatic domains as well as in the control of quantities being measured. Instrumentation finds application in the measurement of physical values of process parameters such as viscosity, flow, temperature, density, liquid level, pressure, voltage, inductance, resistance, capacitance, vibration, weight, current, frequency, *etc.*

## Practical Examples of System Automation and Control

Ilesanmi Afolabi Daniyan<sup>1\*</sup>, Lanre Daniyan<sup>2</sup>, Adefemi Adeodu<sup>3</sup> and Felix Ale<sup>4</sup>

<sup>1</sup> Department of Industrial Engineering, Tshwane University of Technology, Pretoria 0001, South Africa

<sup>2</sup> Department of Instrumentation, Centre for Basic Space Science, University of Nigeria, Nsukka, Nigeria

<sup>3</sup> Department of Mechanical Engineering, University of South Africa, Florida, South Africa

<sup>4</sup> Department of Engineering & Space Systems, National Space Research & Development Agency, Abuja, Nigeria

**Abstract:** This chapter provides a practical demonstration of how a system's automation can be achieved. Some specific examples presented include the automation of irrigation systems, waste segregator, gasifiers, biodiesel plants, biogas plants, lawn mowers, assembly line automation as well as the automation and control of the suspension system of a railcar. The details of the design and components required for the automation of these systems are highlighted. The chapter presents practical guided approaches by which system automation can be achieved depending on the end-users requirements. The practical examples highlight the integration of sensors (for measuring conditions/parameters), controllers (for processing inputs and decision-making) as well as actuators (for effecting changes) with minimal or no human interference. System automation is connected to the engineering field called mechatronics which is an interdisciplinary engineering branch comprising a combination of mechanical, computer, electrical and electronic systems. The automation of systems will enhance profitability, improved production rate, product quality, and safety.

**Keywords:** Actuator, Controller, Sensor, System automation.

### INTRODUCTION

The preceding chapters have dealt with the theoretical concepts of automation and control. This chapter discusses the practical ways by which processes or systems can be automated and controlled. It is noteworthy to mention that there is no single solution or approach for the automation and control of all systems as the

---

\* Corresponding author Ilesanmi Afolabi Daniyan: Department of Industrial Engineering, Tshwane University of Technology, Pretoria 0001, South Africa; Tel: +27 (064) 5298778; E-mail: afolabiilesanmi@yahoo.com

automation and control of production systems can be tailored towards the production requirements and the bottom-line goal of profitability. This chapter discusses various systems as well as the materials required for their automation and control including feasible methods by which this can be achieved.

## IRRIGATION SYSTEM

The purpose of automating the irrigation system is to reduce human intervention in supplying water for farmland irrigation and also to enhance effective water management. The capability of an automated irrigation system is the ability to take intelligent decisions with respect to the need for irrigation based on operational and soil conditions [1, 2].

## AUTOMATION OF THE IRRIGATION SYSTEM

The automation of a standalone irrigation system will require the following; an Arduino microcontroller (main controller), an oscillator, a DC water pump, a PV module, LCD, a real-time clock module, a soil moisture sensor, a sim card, switches, relay, an led, capacitors and resistors [1, 2]. The Arduino Uno microcontroller provides a modular way of interfacing the real world with computer systems to get some activities accomplished on a chip in connection with the sensors. The Arduino whose technical specification is shown in Table 1 will be sufficient for the automation of a mini-standalone irrigation system.

**Table 1. Technical specifications of the Arduino Uno.**

S/N	Item	Value	Remarks
1	Micro-controller	8-bit Atmel ATmega328p	Arduino
2	Operational voltage	5V	The range of input is 6-12 V
3	Digital GPIO	14	6 capable of PWM
4	Analog IO	6	10-bit
5	Program memory	Flash 32kb, EEPROM 1kb	SRAM 2kb
6	Clock speed	16MHz	-
7	USB	Type B socket	-
8	Programmer	In-system firmware	USB-based
9	Serial communications	SPI, I2C	Software UART
10	Other	RTC, watchdog, interrupts	-

The Arduino is programmable with the use of Arduino IDE coded in a programming language.



## System Architecture

The soil moisture sensor will check for the environmental conditions with respect to the pre-set time and feeds the microcontroller. The microcontroller is programmed such that the actuator is actuated for irrigation once the soil moisture level falls below 25%. The microcontroller also stops the actuator once the soil moisture rises up to 50%. Anytime any of these two conditions is met the microcontroller activates the relay to switch on the irrigation pump for irrigation purposes. On the microcontroller, the signal is read, and converted into a digital signal with the threshold humidity preset on it. Anytime these two conditions are active (time and humidity value falling below the threshold), a relay is activated by the microcontroller to switch the irrigation pump ON. A Short Message Service (SMS) alert is then sent to the authorized user on the state of the pump and the active mode of the control. The status of the pump changes from “PUMP OFF” to “PUMP ON” once the relay activates the pump. In case of an emergency need for water that is not dependent on the soil moisture, the system is incorporated with a manual mini switch which can be used to activate the pump.

Fig. (1) presents the architecture of the developed irrigation system.

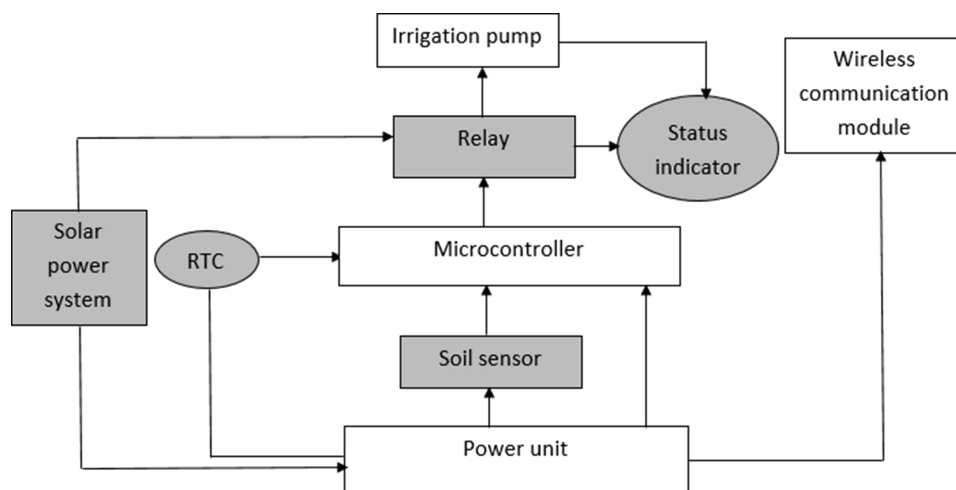

Fig. (1). Architecture of the developed automated irrigation system [1].

A timer (DS1307) is integrated to precisely record and track the time and date of the irrigation operation.

Fig. (2) presents the Proteus diagram showing the integration of the components of the irrigation system.

## CHAPTER 9

## Water Distribution Management in Real Time: Using a Cloud-Based Approach

Kazeem Aderemi Bello<sup>1,\*</sup>, Ilesanmi Afolabi Daniyan<sup>2</sup>, Osato Alexandra Ighodaro<sup>3</sup>, Adefemi Adeodu<sup>3</sup> and Wasiu Adeyemi Oke<sup>4</sup>

<sup>1</sup> Department of Mechanical Engineering, Federal University, Oye-Ekiti, Nigeria

<sup>2</sup> Department of Industrial Engineering, Tshwane University of Technology, Pretoria0001, South Africa

<sup>3</sup> Department of Mechanical and Mechatronics, Afe Babalola University, Ado Ekiti, Nigeria

<sup>4</sup> Department of Mechanical Engineering, University of South Africa, Florida South Africa

**Abstract:** Lack of access to potable water has become an issue of concern in our society. In order to satisfy the increasing water demands of the galloping population in Nigerian communities, it is essential to use smart technology to manage water resources. The purpose of this research work is to ensure that inaccessibility to water as a result of pump failure is detected in real-time through smart technology. To solve this daunting challenge, an Arduino microcontroller and Liquid Crystal Display (LCD) were used to switch on and switch off the submersible pump at a predetermined Water Level (WL) in the tank and also to determine the pump availability hours. The WL in the tank was monitored using an Arduino microcontroller, sensors, relays, and LCD. A Global System for Mobile telecommunication (GSM) module was also used to create an interactive medium between the user/maintenance team and the system to monitor the submersible pump reliability based on engineering theory and concept. The system was tested by introducing varying volumes of water in a constructed water distribution system prototype in the laboratory. The microcontroller was efficient in controlling the system; the pump was able to switch on and switch off when the WL in the tank was 50% and 100%, respectively. As an autonomous system, it was capable of taking decisions automatically without human interference. The system was able to send feedback *via* SMS to alert the user/maintenance team to check the pump whenever it failed to pump water at  $WL \leq 50\%$ . This innovative design system will help to monitor and manage water distribution properly and it should be considered for use in schools, hospitals, residences, offices, *etc.* to ensure the availability of water always, save energy consumption and help in combating covid-19.

**Keywords:** GSM module and Arduino microcontroller, Real-time, Submersible pump, Water distribution.

---

\* Corresponding authors Kazeem Aderemi Bello: Department of Mechanical Engineering, Federal University, Oye-Ekiti, Nigeria. Tel: +234 (080) 36386760; E-mail: itanooluwaponmile@yahoo.com

## INTRODUCTION

Lack of access to potable water in Nigerian communities has been a great challenge, although there is no global water scarcity, accessibility has been a major challenge [1]. The purpose of this research work is to ensure that inaccessibility to water as a result of pump failure is detected in real-time through the use of smart technology. The sustainability of available water resources in many parts of the world is now a dominant issue [2]. This problem is about poor water allocation, inefficient use, and lack of adequate and integrated water management [3]. The common method of level control in water storage tanks for most Nigerian communities is simply to start the pump when the water level in the storage tank is low and allow it to run until a higher water level is reached or the water overflows from the water storage tank. This method is not adequate for proper control of the system. Liquid level control systems are widely used for monitoring liquid levels. Usually, this kind of system provides continuous level indication [4]. Proper water distribution and management are required to ensure water sustainability. Presently, floaters are being used to regulate the pumping of water. This does not provide an efficient method of monitoring the water in the tank. The need to constantly wash hands as a way of combating COVID-19 has further necessitated easy accessibility to water in many homes, offices, colleges, industries, *etc.* in recent times. The challenge of lack of access to water may not be due to a lack of resources to make water available but most times it happens due to faults in the system that go undetected for a long time. In residential areas, people switch ON the water pumps and set off to work or fall asleep, forgetting to switch OFF the water pump when the tank is full. This results in wastage of water due to overflow in overhead tanks, flooding of premises, and wastage of energy. Without proper water monitoring and management, water cannot be available and supplied properly.

Clean water is not accessible to a significant percentage of the world's population [5]. It is estimated that about 2.2 billion people worldwide lack access to potable water and about 297,000 children less than five years of age die every year from unsafe drinking water [6]. Water-related diseases are the single largest cause of human sickness and death in the world and mostly affect the poor population [7]. The UN estimates that each person requires at least 50 liters to 100 liters of clean, safe water a day, for drinking, cooking, washing, bathing, flushing toilets, planting, sanitation, *etc* [8]. Although clean water is scarce all over the world, Africa is the world's poorest and most underdeveloped continent because of a myriad of reasons that embrace a lack of access to potable water [9]. Water scarcity trends as one of the foremost underestimated problems globally, it is one of the more threatening challenges in Africa [10]. Water scarcity is due to physical shortage, or scarcity in access which itself is a result of failure to ensure

regular supply or because of lack of infrastructure to make clean water accessible. The Food and Agriculture Organization [11] estimates that by 2030, up to 250 million individuals in Africa would be living in areas of high-water crisis. Due to a lack of sanitation and purification strategies, many people in Ghana suffer from water-related diseases [12]. About 80% of wealthy Nigerians have access to minimum basic water supply, compared to only 48% of poor Nigerians [13]. Nigeria's three tiers of government share the responsibility for managing water resources and for providing water, but over the years, there has been gross inefficiency and confusion in the area of water distribution and management. The available rural wells are fitted either with submersible pumps or with hand-operated pumps for water supply. These sources yield very little or no water throughout the dry season and are at risk of frequent breakdowns, resulting in water shortages and even crises. Usually, after only a few years, several of those wells become faulty due to lack of funds for operation or poor maintenance, sometimes, general maintenance is nonexistent [14]. A more flexible and responsible water management system is required. In a research work by Olalekan [15], the researcher observed that the water crisis in Nigeria is not new; it has been embedded in the Nigerian States since the colonial days.

In advanced countries, there is a new technology for "atmospheric water generation" that provides high-quality water by extracting water from the air by cooling the air into condensed water vapour [16]. A submersible pump driven by an electrical motor raises the water to the surface. Most times, a deep well may actually penetrate a confined aquifer; in this case, hydrostatic pressure will raise the water to the surface naturally. Drilling deep prevents microorganisms like bacteria and pollution from entering the well. This also reduces issues of wells drying up because of seasonal fluctuations (the distinction between wet and dry seasons) in the water table. The process of pumping water from underground is very expensive hence restricting the full development and use of all groundwater resources [17].

Surface water and groundwater are both important sources of community water supply needs. Groundwater is a common source for homes and small towns [17]. These systems consist of pipes, pumps, valves, storage tanks, reservoirs, meters, fittings, public hydrants, chlorination equipment and other hydraulic accessories. According to Faizah [18], the design of a distribution system depends on the determination of storage, the location and size of the feeder, the location and size of distribution pipes, valves, and hydrants, and the determination of the pressure required in the system. In designing a water distribution system, it is necessary to survey the area leading to the source of supply. Often a trained engineer carries out the required survey, to determine the route that the feeder pipe will follow and the location of distributing reservoirs and main pipes. This survey is followed by a

## Development of Automated Waste Segregator

Ilesanmi Afolabi Daniyan<sup>1,\*</sup>, Adefemi Adeodu<sup>2</sup>, Jacobs Kelechi<sup>3</sup> and Lanre Daniyan<sup>4</sup>

<sup>1</sup> Department of Industrial Engineering, Tshwane University of Technology, Pretoria 0001, South Africa

<sup>2</sup> Department of Mechanical Engineering, University of South Africa, Florida, South Africa

<sup>3</sup> Department of Mechanical & Mechatronic Engineering, Afe Babalola University of Nigeria, Ado Ekiti, Nigeria

<sup>4</sup> Department of Instrumentation, Centre for Basic Space Science, University of Nigeria, Nsukka, Nigeria

**Abstract:** One of the major problems with waste generation today is the huge percentage of plastics in its composition. The automated waste segregator is a mechatronic system that solves this problem by the incorporation of high calibrated sensors and mechanical properties into its design to enable the smooth segregation of plastics and metals. It is capable of detecting and separating these components as soon as they get to its sensing unit with the aid of capacitive proximity sensors and ultrasonic sensors. The capacitive proximity sensor made with plated iron detects the type of material in range either plastics or metals based on their dielectric constant. A 12V DC geared motor made with aluminum and iron of high torque and speed characteristics is connected to the lids to enable its automatic open and close mechanism. Also, a microcontroller (PIC18F452) was used to control the entire segregation process of the system and is capable of storing and implementing the software in real-time. The sensors are controlled by the PIC18F452 microcontroller and based on the sensor readings, pulses are sent from the controller to the geared motor for the fast action of lid opening. The results of the performance evaluation indicated that the automated waste segregator has the capacity to identify and sort wastes into plastics, metals and any other waste with the aid of a capacitive sorting technique.

**Keywords:** Environmental Hazards, Microcontroller, Pollution, Proximity Sensors, Waste.

### INTRODUCTION

The major problem with waste generation today is the huge percentage of plastics in its composition. The burning of the waste components produces a very toxic

---

\* Corresponding authors Ilesanmi Afolabi Daniyan: Department of Industrial Engineering, Tshwane University of Technology, Pretoria 0001, South Africa; Tel: +27 (064) 5298778; E-mail: afolabiilesanmi@yahoo.com

gas known as dioxin that is dangerous to human health and can endanger green life as well as constitute environmental hazards. Many methods have been employed for carrying out waste segregation for various types of materials namely the manual methods, sensor implementation, electromagnetic, and x-ray sorting. The manual method involves hand-sorting which is harmful and laborious [1, 2]. On the other hand, the waste sorting based on the use of smart sensors utilizes the capacitive, inductive and infrared sensors to segregate waste depending on the characteristics and properties of wastes to be sorted [3]. An electromagnetic separator used for separating metals utilizes an eddy current when a conductor is exposed to magnetic field making it possible for metals to be separated from non-metals. The x-rays sorting method sorts the materials based on their atomic densities. It achieves a high-resolution level of sorting regardless of moisture and pollution level of waste to be sorted. The use of energy-resolved photon-counting detectors with multiple thresholds, which allow simultaneous measurements of the x-ray attenuation at multiple energies, allows separation [4-5]. The effective sorting out of waste materials will provide an opportunity for recycling and reuse of some waste products [6 - 8]. For instance, plastics and metals can be recycled and put to better use instead of causing environmental pollution but because of being mixed-up with other components in the waste stream, it makes their management extremely difficult. The need for proper waste management in the environment cannot be over-emphasized as waste management issues are interfering significantly with humans' overall well-being and society both on a large and small scale. Improper waste disposal can cause ailments like asthma, emphysema and other environmental hazards and pollution if not managed properly [9-11]. Waste is generally generated per seconds in the manufacturing industries, communities, schools and homes and hence the need for an efficient, effective and sustainable waste management system that incorporates proper sorting of waste components. The automated waste segregator is a mechatronic system that is able to separate waste namely; plastics, metals and house waste. Through the use of an analog sensor (capacitive proximity sensor), the system is able to detect plastic and metallic materials and separate them by the movement of electric motors and a conveyor system. The automated waste segregator is incorporated in an electronic bin making up a compact and effective system. Many researchers have reported on the development of automated waste sorting machines [12-15], the novelty of this work, however, lies in the compatibility of the system with Bluetooth and Android applications for querying and feedback. This will enhance real-time monitoring of the waste sorting activities.

## **MATERIALS AND METHOD**

The materials employed for the purpose of this study include: a capacitive proximity sensor (with a sensing range of 2-40 mm for detecting both metal and

non-metals), an ultrasonic sensor made of silicon-based PCB and partly aluminum, a 12V DC geared motor made with aluminum and iron of high torque and speed characteristics, a microcontroller (PIC18F452), a circuit board, a vero board, and L293D motor driver. The four sections employed in the design and fabrication of automated waste segregation are: electrical and electronic systems integration, fabrication and software implementation. The materials selection considers the service and functional requirement as well as the material's cost availability. The major components used in the electrical and electronics phase are the capacitive proximity sensor made with plated iron which detects the type of material in range either plastics and metals based on their dielectric constant; an ultrasonic sensor made of silicon-based PCB and partly aluminum, a 12V DC geared motor made with aluminum and iron of high torque and speed characteristics that is connected to the lids to enable its automatic open and close mechanisms, and a microcontroller (PIC18F452) used to control the entire segregation process of the system and capable of storing and implementing the software in real-time. This is the heart and brain of the system where all the peripheral devices are connected to the first analogue channel of the microcontroller (R1). The L293D pins are connected to the CCP pins of the microcontroller for speed control. The ultrasonic sensor is connected to RB7 and RB6 while the trigger is connected to RB7 and ECHO to RB. The GND pin is connected to the common ground and the Vee to +5V voltage source. The circuit board is used to hold all the electrical and microcontroller components of the system, connecting wires used to make connections of the circuitry on a Vero board. An L293D motor driver is employed for controlling the motion of the electric DC motors. Other components in this phase include a dozen of 9 volts batteries, capacitors, resistors, a 5 V voltage regulator, a crystal oscillator (4 MHz), pushbuttons and integrated circuit chip sockets. Figs. (1-3) show the circuit design, its implementation and the block diagram of the system.

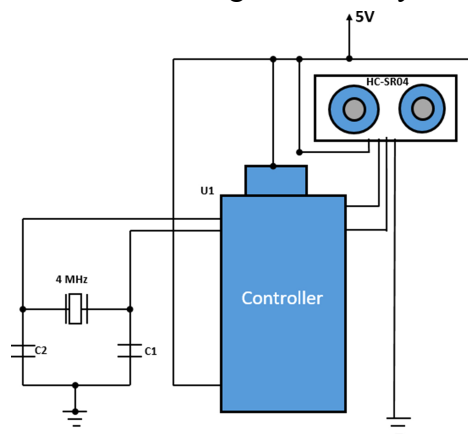

Fig. (1). Ultrasonic sensor interfacing with PIC18F452 microcontroller.

**CHAPTER 11****Development of a Fire Detection and Extinguishing Robot****Ilesanmi Afolabi Daniyan<sup>1\*</sup>, Adefemi Adeodu<sup>2</sup>, Bankole Oladapo<sup>3</sup>, Vincent Balogun<sup>4</sup> and Ididiong Etudor<sup>5</sup>**<sup>1</sup> *Department of Industrial Engineering, Tshwane University of Technology, Pretoria, South Africa*<sup>2</sup> *Department of Mechanical Engineering, University of South Africa, Florida, South Africa*<sup>3</sup> *School of Engineering and Sustainable Development, De Montfort University Leicester, Leicester, UK*<sup>4</sup> *Department of Mechanical Engineering, Edo State University, Iyamho, Nigeria*<sup>5</sup> *Department of Mechanical Engineering, Afe Babalola University, Ado Ekiti, Nigeria*

**Abstract:** Robotics finds application in firefighting services. This work considers a robot that is able to detect fire and extinguish it. The robot operates automatically, avoiding obstacles, and at the same time, it is capable of detecting, tracking, and extinguishing flames. To achieve the best performance with an effective implementation, a modular design strategy was adopted, where the robot is divided into a number of logical modules based on functionality. The design consists of five main modules: the master controller, motor control, proximity control, fire detection and fire extinguishing module. Each module is associated with appropriate sensors and actuators. The information from various sensors and key hardware elements is processed *via* the PIC18F452 microcontroller. This is then interfaced with the master controller which coordinates and schedules the task of the entire robotic system. The performance evaluation indicates the robot's capability to detect and extinguish flames, hence, this work will generate interest as well as innovations in the field of robotics while working towards practical and obtainable solutions to save lives and mitigate the risk of property damage.

**Keywords:** Actuators, Microcontrollers, Modules, Sensors.

**INTRODUCTION**

In recent years, the advent of the Fourth Industrial Revolution (4IR) has continually promoted the capabilities of robotic solutions as an intelligent and autonomous system with effective service delivery [1]. Robotics has gained popularity due to the advancement of many technologies of computing and

---

\* **Corresponding authors Ilesanmi Afolabi Daniyan:** Department of Industrial Engineering, Tshwane University of Technology, Pretoria 0001, South Africa; Tel: +27 (064) 5298778; E-mail: afolabiilesanmi@yahoo.com



nanotechnology, thus, making product development and services efficient, easier, and comfortable [2, 3]. Most robots have augmented microcontrollers (a small control system with input and output control capabilities). Robotic situation finds useful application in the dangerous or hazardous environment as well as difficult-to-reach area. Firefighting is an important but dangerous occupation and can cause the death of personnel, destruction of properties, and permanent disabilities [4, 5]. Hence, the associated risks can be mitigated with the deployment of a robot for firefighting operations. Firefighting must be able to provide a quick emergency response with the ability to get to the scene of a fire quickly and safely extinguish the fire in order to prevent further damage and reduce fatalities [6 - 8]. Since technology has finally bridged the gap between firefighting and machines, allowing for a more efficient and effective method of firefighting, a robot can be designed to function by itself or be controlled from a distance, which means that firefighting and rescue activities could be executed without putting the firefighters at risk through the use of robot technology. The robot employs a microcontroller designed to accept input from a set of electrical signals and give output in the form of electrical signals in response to commands programmed into the device. The microcontrollers, which interpret a human interface and send electrical signals to the rest of an electronic device, are often implemented as small, embedded processors found in many modern electronic devices. The versatility of microcontrollers is because they are considered tiny cost-effective computers which operate like a single integrated circuit. In addition, they are programmable, affordable, and lightweight, require minimum power, and range from different varieties to suit every need [9 - 11]. A firefighting mobile robot is one of the solutions that are able to reduce the hazards and risks of a firefighter [12 - 14]. Xu *et al.* [15] designed a firefighter robot capable of searching, detecting, and extinguishing fire in a small floor plan of a house. It also has the capability to move about and avoid obstacles. The navigation of the robot is achieved by the data provided by a line tracker and ultrasound transducers. The deployment of the extinguishing device is implemented with a custom arm controlled by servos. Ratnesh *et al.* [16] developed an approach toward the implementation of a firefighting robot. It employs the concept of environmental sensing and awareness as well as proportional motor control. The robot processes information from its sensors and hardware elements while ultraviolet, infrared, and visible light are used to detect the components of the environment. The robot is capable of fighting tunnel fire, industry fire, and military applications. Saravanan [17] developed an integrated semi-autonomous firefighting mobile robot. The system controls four D.C. motors powered by an Atmega2560 microcontroller and it is controlled autonomously by the navigation system. Furthermore, Poonam *et al.* [18] developed an intelligent fire extinguishing system that uses a smoke sensor, flame sensor, and temperature sensor for fire detection. The system detects the fire

location and extinguishes it using the sprinklers method. Meanwhile, most researchers are working on feasible solutions to help robots think more efficiently, move and navigate in a smoother way [19-21]. This work considers the development of a fire detection, tracking, and extinguishing robot. The systems' capability includes the ability to operate automatically, avoid obstacles and at the same time, find and track and extinguish flames *via* a modular design strategy. The robot has the ability to act and think independently mimicking humans but with much degree of flexibility. The development of sensor networks and the maturity of robotics suggest that mobile agents can be employed for tasks that involve prompt perception and reaction to an external stimulus, even when the reaction involves a significant amount of mechanical actions. This provides the opportunity to pass on to robots, tasks that traditionally humans had to do but were inherently life-threatening such as fire-fighting, hence, fire-fighting is an obvious candidate for automation in this regard. Given the number of lives lost regularly during firefighting operations, the system can be deployed to mitigate the hazards and associated risks involved in the firefighting operation. Experience suggests that designing a fire-fighting system with sensors and robots is within the reach of the current sensor network and mobile agent technologies. Furthermore, the techniques developed in this work will carry over to other areas involving sensing and reacting to stimulus, where it is desired to replace humans with an automated mobile agent. Fire accidents can occur anywhere at any time and it rapidly spreads causing havoc.

## METHODOLOGY

The design consists of five main modules: the master controller, motor control, proximity control, fire detection and fire extinguishing module. Each module is associated with appropriate sensors and actuators. The information from various sensors and key hardware elements is processed *via* the PIC18F452 microcontroller. This is then interfaced with the master controller which coordinates and schedules the task of the entire robotic system. The following specifications were made for the design of the fire-detecting and extinguishing robot: six (6) panels of sensors, in order to have a 360-degree view for flame detection, servo, and DC motors, ultrasonic sensors for obstacle detection, and CO<sub>2</sub> fire extinguisher.

The robot has a modular design as illustrated in Fig. (1), where the entire task to be performed by the robot is split into:

The flame detection and tracking module comprises two flame sensors (YL-38), based on the light wavelength ranging from 750-1200 nm for flame detection, and an ultrasonic sensor (HC-SR04) for obstacle detection and avoidance. The signals measured by the sensors in real-time serve as input into the microcontroller.

## Performance Simulation of a Solar-Powered and Hand Gesture Controlled Lawn Robot using Dynamic Movement Primitives (DMP)

Adefemi Adeodu<sup>1,\*</sup>, Rendani Maladzhi<sup>1</sup>, Mukondeleli Grace Kana-kana<sup>2</sup>, Ilesanmi Afolabi Daniyan<sup>2</sup> and Kazeem Aderemi Bello<sup>3</sup>

<sup>1</sup> Department of Mechanical Engineering, University of South Africa, Florida, South Africa

<sup>2</sup> Department of Industrial Engineering, Tshwane University of Technology, Pretoria 0001, South Africa

<sup>3</sup> Department of Mechanical Engineering, Federal University, Oye-Ekiti, Nigeria

**Abstract:** Hand-gesture interpretation and control in robotics describe the interconnection between human and machine elements in the computer vision world. Pruning a structured environment is time-consuming and labor-intensive. Therefore, it requires management by a self-propelled machine. The path planning mode allows the robot to move along a specified path. Various studies on lawn mower robots focus more on obstacle avoidance with hand gesture interpretation and control implemented to take care of path definition. This study targets the development of a solar-powered lawn mower robot using hand gesture control as a path-planning technique. The robotic system continuously operates using charged batteries *via* solar energy stored in photovoltaic cells. The robot control mechanism was implemented *via* the use of infrared sensors to avoid obstruction on its path, and hand gesture interpretation *via* a DSP processor for path planning. The performance evaluation of the robot was based on field experiments and simulations using SolidWorks, defined in terms of area covered, lawn availability, energy utility, and optimum turning velocity. The evaluation revealed that the machine's efficiency is almost 100% based on the area covered, the percentage availability of the robot is 95%, and the average energy utility of 7.7 KWh was also obtained. The optimum turning velocity of 0.096 m/s at work with a completion time of 20 minutes was obtained by simulation. This robot is useful for any environment, both structured and semi-structured.

**Keywords:** Area covered, Digital signal processing, Hand gesture, Robotic, Obstacle avoidance.

---

\* Corresponding author Adefemi Adeodu: Department of Mechanical Engineering, University of South Africa, Florida, South Africa; Tel: +27 (087) 223718; E-mail: eadeodao@unisa.ac.za

## INTRODUCTION

Hand gesture recognition and interpretation in robotics is a type of machine-human interaction implemented in the field of computers when dealing with path planning. On this basis, robotic systems take definite instructions for carrying out tasks relative to directions. This work is an extension of the work originally presented in ICAST by Adeodu *et al.* [1]. The study of gesture identification and interpretation distinguishes defined body movements and communicates the message to the user to establish the link between humans and machines [2, 3].

Hand gesture control finds a wide range of applications in telerobotics, where machine systems are naturally manipulated with such telerobotic communication [4 - 6] to serve information relating to directions to the machine, such as left, right, *etc.* Its application in the lawn mower robot is a simple and unique method of controlling the geometric movement of the robot as a means of path planning. The aesthetic value maintenance of an environment, structured, or semi-structured is generally labor-intensive and time-consuming [1]. Therefore, the need for executing the task effectively is of utmost importance.

Several works have been reported on the development of lawn mowers. For instance, the CWRU is a grass cutter robot that captures and processes images using a 1.83 GHz run on the Windows XP operating system with 4GB memory. Efficient computations and robust obstacle identification methods were used in this robot based on image hue and intensity [7 - 10]. Deranda *et al.* [11] developed a smart robot lawn mower that does not require a boundary cable for its operation to reduce the cutting cycle time and operational cost. Ahamed and Ziauddin [12] developed a small-scale electric lawn mower while Tanimola *et al.* [13] developed a solar-powered lawn mower that can harness the potential of solar energy as a renewable source. In addition, Namoco *et al.* [14] developed a mechanical push lawn mower with a double cylinder for blade spinning to increase the system's capacity and operational efficiency while Moore *et al.* [15] performed the measurement and analysis of a lawn mower in terms of its performance and noise level. Many other works have been reported on the development of autonomous lawn mowers and systems that require the installation of boundary wire around the perimeter of the lawn area to keep the machine within the predetermined area and path to be cut [16 - 19].

The contribution of this work was demonstrated by configuring hand gestures to define the path of a solar-powered grass-cutting robot. This was achieved by showing hand movements in front of a high-resolution camera linked to a digital signal processing (DSP)-based embedded board, which captured the image in real-time. An algorithm based on a DSP processor TMS320DM642EVM was

used to evaluate actuation *via* many hand gestures without contact with the surface of the screen. Real-time performance was made possible, which extended the limit of applications to include those with high frame rates. The robot's gesture learning was accomplished *via* dynamic movement primitives (DMP). Dynamic movement primitives are represented by dynamical systems and can be generalized by modifying initial values and tuning parameters based on environmental changes [20]. Hence, they can be executed from different initial and final poses with a similar but not the same trajectory, which eases the task of making robots more social. Therefore, this work approaches cognition from a dynamic system's perspective.

### Dynamic Movement Primitives

Dynamic Movement Primitives (DMP) is a method for trajectory control planning that was originally derived from Stefan Schaal's laboratory in 2006 and later updated by Auke Ijspeert in 2013 [21]. A detailed and highly illustrative explanation of DMP can be found in [22]. The trajectory that defines the DMP is a point attractor dynamic equation, which is presented in Eqs. (1-11).

$$\dot{y} = \alpha_y \{ \beta_y (g - y) - y \} \quad (1)$$

Where  $y$  is the system state,  $g$  is the goal,  $\alpha$  and  $\beta$  are gain terms. This kind of system can be seen as a proportional derivative control signal governing the system to the target [23]. To modify the trajectory by adding a force term, Eq. (1) is transformed as follows:

$$\dot{y} = \alpha_y \{ \beta_y (g - y) - y \} + f \quad (2)$$

Defining a non-linear function that achieves the desired behavior is not a trivial task. To generalize and make the trajectory time-independent, a new system called the canonical dynamic system is introduced, which has very simple dynamics:

$$\dot{X} = -\alpha_x X \quad (3)$$

The canonical system originated at some arbitrary value such as  $x_0 = 1$  and goes to infinity. Hence the forcing function  $f$  can be defined over a basic function  $\vartheta_i$  defined on canonical system  $x$ .

$$f(x, g) = \frac{\sum_{i=1}^N \vartheta_i w_i}{\sum_{i=1}^N \vartheta_i} X(g - y_0) \quad (4)$$

**CHAPTER 13****Experimental Design and Modelling of Automated 4-Cylinder Engine Injector****Kazeem Aderemi Bello<sup>1,\*</sup>, Abdulrahman Adama<sup>1</sup>, Olasunkanmi Adekunle Odunaiya<sup>1</sup> and Cordelia Ochuole Omoyi<sup>2</sup>**<sup>1</sup> *Department of Mechanical Engineering, Federal University, Oye Ekiti, Nigeria*<sup>2</sup> *Department of Mechanical Engineering, University of Calabar, Calabar, Nigeria*

**Abstract:** The global emission regulations and fossil fuel pollution control have necessitated the need to study the effect of injector fuel splitting time and flow rate on engine performance. To achieve this, an automated prototyped 4-cylinder injector engine was developed to replicate the real-time activities of the injector system in the internal combustion (IC) engine. Arduino Nano open-source platform was used to integrate the various component parts such as the fuel injector, fuel tank, submersible fuel pump injector rail, transparent plastic chamber, flexible hose, Engine Control Unit (ECU), connecting wires, frame, Liquid Crystal Display (LCD), switch button, relay module, current sensor, potentiometer, Arduino nano, and pressure sensor that were used for the design experiment. Programmable circuit board microcontroller, Arduino (Integrated Development Environment) IDE, and C++ coding language were used to achieve the smart regulations of the injector operation system to replicate the real-time situation when the engine is running. This was achieved by incorporating Arduino microcontroller ATMEGA328, C++, and Arduino IDE software. The Arduino programming initiates the injection system and measures the injection output parameters. The system was designed to vary the splitting time delay between the four injectors and to measure the flow rate of the fuel injected. The experimental study showed that at a very high splitting time delay, the amount of fuel injected is more than the fuel injected at a relatively low splitting time delay with an average flow rate of 4.36 l/min at 50 microseconds and 0.02 l/min at 500 microseconds for high and low splitting time, respectively. This study will help the stakeholders in the automotive industry to virtualize the invisible situation of the fuel injector in real-time performance in the engine.

**Keywords:** Arduino Nano, Automation, Fuel injection, Microcontroller, Potentiometer.

---

\* **Corresponding author Kazeem Aderemi Bello:** Department of Mechanical Engineering, Federal University, Oye Ekiti, Nigeria Tel: +234 (080) 36386760; E-mail: itanooluwaponmile@yahoo.com

## INTRODUCTION

The fuel injection control system directly affects fuel efficiency and pollution level. Environment pollution and energy consumption have become serious concerns associated with engine control technology [1, 2]. The self-tuning control technique is applied to improve engine performance by controlling the engine speed and exhaust flow [3]. Most fuel injection systems are for gasoline or diesel applications. With the advent of electronic fuel injection (EFI), diesel and gasoline hardware have become similar. EFI's programmable firmware has permitted common hardware to be used with different fuels. Injector faults have negative effects on engine performance and they could cause engine misfiring, knocking, low thermal efficiency, or cause a total engine breakdown [4, 5]. During real-time monitoring of an engine injector performance, the Short-Term Fourier Transform (STFT) technique was used for fault diagnosis of fuel injection nozzles and knock detection [6, 7]. It is therefore necessary to prevent injectors' faults in an engine by monitoring their performance [8]. Condition monitoring of diesel engines can prevent unpredicted engine failures and the associated consequences [9]. An experimental study was carried out to instigate the use of gasoline fuel in a port injector in a single-cylinder Air-cooled HSDI Diesel Generator [6]. The variable intake temperature and fuel split quantities were used to determine different combustion regime phases. This type of engine usually is available in four-stroke and two-stroke engines. In the four-stroke of ICE, each piston will undergo two strokes per crankshaft revolution in a certain order. The first order or stroke is the 'Induction' order where the intake valves are open and the exhaust valves are closed, and the piston moves downward increasing the volume of the combustion chamber thus allowing a mixture of air and fuel to enter the chamber. Next, is the 'Compression' stroke where both the intakes and exhaust valves will close as the piston moves upward until it reaches its top dead centre to decrease the volume of the chamber but increase pressure. Numerical simulations of compression ignition processes using a gasoline fuel injector at low pressure and hollow cone were investigated. The results showed good agreement with the experimental data in terms of pressure, thermal efficiency profile and emissions [7]. A fuel injection system (FIS) for a petrol engine is a system that utilizes fuel injectors instead of carburetors. The difference between carburetors and fuel injection is that fuel injection atomizes the fuel through a small nozzle under high pressure while carburetors rely on the suction power created by the air intake accelerated through a venturi tube to make the fuel into the airstream [10, 11]. The system works by determining the necessary amount of fuel, and its delivery into the engine is known as fuel metering [12, 13]. The early production of fuel metering was useful in mechanical methods and as time goes by, the modern system uses electronic metering which is more precise and smaller in size. At present time, more researchers are trying to convert the internal combustion

system engine into a fuel injection system engine either a standard fuel injection system or direct fuel injection system because theoretically fuel injection systems bring more benefits to the consumers and are also environment friendly compared to the internal combustion system [14, 15]. The study on CFD modeling of the in-cylinder flow in direct-injection Diesel engines showed that the piston geometry had a minimum influence on the in-cylinder flow during the intake stroke and the first part of the compression stroke [16, 17]. However, the bowl shape plays a significant role in TDC and in the early stage of the expansion stroke by controlling both the ensemble-averaged mean and the turbulence velocity fields. The effects of the Abrasive Flow Machining (AFM) process on a direct injection (DI) Diesel engine fuel injector nozzle were studied [18, 19]. Geometry characterization techniques were developed to measure the microscopic variations inside the nozzle before and after the process [20]. Several studies had been conducted on empirical correlations of the nozzle geometry change due to the AFM process [21, 22] In modern automotive internal combustion engines, a variety of injection systems existed. A fuel injection system is designed and calibrated specifically for the types of fuel it will handle. Most fuel injection systems are for gasoline or diesel applications. With the advent of electronic fuel injection (EFI), diesel and gasoline hardware have become similar. EFI's programmable firmware has permitted common hardware to be used with different fuels. Basic components in a fuel injection system are a fuel injector, high-speed camera and electronic control unit (ECU) such as an injector driver and digital delay generator for the signal line while other components include a fuel tank, a fuel filter, a high-pressure pump and a pressure regulator for the fuel line. In the laboratory experiment, the high-pressure chamber is used as the main instrument to identify spray patterns. Some of the experiments use high-speed cameras with personal computers and ECU. The data gained will be shown on the personal computer automatically. The fuel injection types used in newer cars include four basic types; Single-point or throttle body injection, Port or multipoint fuel injection, Sequential fuel injection, and Direct injection. This study will serve as a teaching guide to stakeholders in the automotive industry to evaluate and improve the existing engine injector.

## **EXPERIMENTAL SET-UP**

The experimental study of the automated cylinder injector system was achieved by using the following materials:

1. Fuel injector: Fuel injectors are nozzles that inject a spray of fuel into the air, basically the fuel injector used in this project is an Audi electronically controlled Injector system.



## SUBJECT INDEX

### A

Abrasive flow machining (AFM) 189  
 AFM process 189  
 Air 27, 48  
     conditioning system 27  
     pressure control 48  
 Algorithms 8, 9, 97, 103, 172, 178  
     clustering 8  
     mathematical 8  
 Aluminum 152, 154, 166  
     and iron of high torque 152, 154  
     material 166  
 Applications 102, 104  
     of industrial automation 102  
     robotic 104  
 Arduino 96, 112, 117, 118, 187, 191  
     board 112, 117, 118  
     development boards 96  
     programming 187, 191  
 Artificial intelligence 12, 103  
     algorithms 103  
     functions 12  
 Artificial neural networks (ANN) 3, 9, 99,  
     100, 106, 180  
 Automated 1, 2, 5, 6, 13, 14, 20, 21, 27, 28,  
     29, 50, 53, 55, 97, 101, 163  
     guided vehicles (AGV) 28  
     material handling systems 29  
     mobile agent 163  
     processes 2, 20  
     production/assembly 14  
     systems 1, 2, 5, 6, 13, 21, 27, 50, 53, 55,  
         97, 101  
     teller machine (ATM) 21, 101  
 Automatic 6, 21, 28  
     assembly machines 28  
     inspection system 21  
     systems 6  
 Automation 1, 2, 6, 11, 13, 20, 21, 22, 27, 29,  
     50, 55, 58  
     cognitive 2, 50, 55, 58

environment 29  
 software 11  
 systems 2, 6, 20, 21, 22, 27, 50  
 technologies 1, 13

### B

Biodiesel plant 108, 113, 129

### C

CAD software 99  
 Calibrated flow rate sensors 112  
 CAM software 99  
 Canonical system 173, 174  
 Capacitive proximity sensor 111, 112, 152,  
     153, 154, 156  
 CFD modeling 189  
 Chemical processes 28  
 Circuit, open-loop system 23  
 Cloud 10, 55, 111  
     computing 10  
     storage 55, 111  
 CNC machines 10, 106  
 Code composer studio (CCS) 156, 175, 178  
 Communication 20, 54, 57, 134, 136, 172  
     microSD 54  
     remote access 54  
     system, wireless 136  
     technologies 20, 57, 134  
     telerobotic 172  
 Computer 58, 102, 105  
     integrated manufacturing (CIM) 58  
     numeric control systems 105  
     systems, automating 102  
 Computer-aided 29, 57, 99  
     design 29, 57, 99  
     manufacturing 99  
 Computer numerical 22, 68, 102, 105  
     control (CNC) 22, 68, 105  
     control machines 102  
 Control 28, 56, 136

- electronic 28, 56
- water flow sensor 136
- Control system(s) 3, 20, 71, 82, 99, 106, 188
  - algorithm 82
  - automation 20
  - fuel injection 188
  - numeric 3, 99, 106
  - open-loop 71
- Corrosion resistance 114, 155

**D**

- Data acquisition system 99, 101, 106
- Detection, automatic 111
- Digital 171, 172, 178, 189
  - delay generator 189
  - signal processing (DSP) 171, 172, 178
- DSP processor 171, 176

**E**

- Electric 22, 27, 37, 153, 190
  - motors 22, 37, 153, 190
  - Iron, automatic 27
- Electrical 22, 105, 137
  - powers 22
  - probes 137
  - resistances 105
- Electromagnetic separator 153
- Electromechanical system 137
- Electronic 7, 54, 143, 162, 188, 189, 196
  - device 7, 54, 143, 162
  - fuel injection (EFI) 188, 189, 196
- Energy 10, 11, 22, 51, 54, 98, 119, 128, 131, 132, 134, 147, 171, 172, 184, 188
  - consumption 131, 134, 147, 188
  - electrical 54
  - kinetic 119
  - loss 128
  - solar 171, 172
  - source 98
  - usage 184
  - visual 51
- Engine, petrol 188
- Environment 1, 3, 7, 9, 12, 13, 21, 32, 95, 101, 103, 137, 153, 158, 162, 171, 172, 188
  - industrial 32, 95
  - industrial control system 13
  - pollution 188
  - wireless 137

**F**

- Financial automated trading systems 100
- Firefighting mobile robot 162
  - integrated semi-autonomous 162
- Flame 163, 164, 167, 168, 169
  - detection 163, 164
  - intensity 164, 168, 169
  - sources 164, 168
  - welding 167, 168
- Flexible manufacturing 3, 16, 28, 56, 99, 103, 106
  - cells (FMC) 106
  - system (FMS) 3, 16, 28, 56, 99, 103, 106
- Flow 3, 16, 28, 45, 56, 67, 85, 99, 103, 106, 113, 134
  - sensor 45, 85, 113, 134
  - switches 67
- Food and animal waste 157
- Force 54, 126
  - damping 126
  - rotational 54
- Fourth industrial revolution 18, 161
- Fuel 168, 187, 188, 189, 190, 194, 195
  - gasoline 188
- Fuel injection 188, 189, 196
  - electronic 188, 189
  - system (FIS) 188, 189, 196

**G**

- Gasoline hardware 188, 189
- Gas pressure 47
  - inflow 47
- Gaussian functions 174

**H**

- Hand-operated pumps 133
- Heating element, resistive 27
- High resolution camera 176
- Human-machine interface (HMI) 2, 3, 50, 54, 55, 99, 100, 101, 106
- Hydrants, public 133
- Hydraulic 7, 98, 101, 133, 136
  - accessories 133
  - systems 7
- Hysteresis 35

**I**

Image 181  
    monochrome 181  
    processing 181  
Inductive reasoning 51  
Industrial 7, 9, 10, 11, 20, 35, 92, 99, 102  
    applications 20, 35  
    automation 7, 9, 10, 11, 92, 99, 102  
Industries 1, 5, 6, 7, 18, 28, 46, 48, 52, 57,  
    162, 169, 187, 189  
    automotive 187, 189  
    engineering 5, 6  
Infrared sensor 153, 171, 176  
Injection system 187, 189, 191, 192, 196  
    electronic fuel 196  
Integrated 66, 92, 96, 187, 191  
    circuits (ICs) 66, 92  
    development environment (IDE) 96, 187,  
    191  
Intelligent process automation 11  
Interfacing, capacitive sensor 155  
Internal combustion 90, 189, 190  
    engine chemically-powered 190  
    system 189  
Internet of things (IoT) 111, 134, 135, 136  
IoT-based 134, 135  
    architecture for water utility monitoring  
    135  
    technology 134, 135  
IoT technology 134

**L**

Language 135, 156, 191  
    python 135  
Language processing, natural 58  
Laplace 81, 86  
    equations 81  
    transformation 86  
LCD(s) 144, 146, 147, 176, 192  
    Indicator 146, 147  
    screen 147, 176, 192  
    display 144  
Light 22, 121  
    energy 22  
    source 121  
Liquid crystal display (LCD) 54, 109, 113,  
    119, 131, 139, 144, 145, 187, 190

**M**

Machine(s) 1, 2, 3, 6, 8, 9, 13, 14, 15, 16, 17,  
    29, 50, 51, 54, 96, 99, 100, 101, 102,  
    105, 106, 172  
    automatic 6  
    drilling 105  
    electronic 29  
    intelligence 8  
    interface (MHI) 2, 3, 50, 54, 99, 100, 101,  
    106  
    photocopying 96  
    vision systems 106  
Machine learning 8, 9, 58, 103  
    algorithms 58  
Machining 7, 102, 106  
    automatic 106  
Management system, sustainable waste 153  
Manufacturing 1, 5, 6, 7, 9, 15, 16, 17, 18, 20,  
    28, 29, 51, 56, 57, 85, 99, 104, 106, 153  
    cellular 16  
    economy 1  
    industries 6, 7, 17, 20, 85, 153  
    problems 99  
    system 15, 28, 56, 57  
    techniques 9  
Manufacturing process 2, 5, 85  
    control 2, 85  
    errors 5  
Matlab software 137, 181  
Microcontroller 116, 142  
    powers 116  
    processor 142  
Microprocessor 94, 95, 96  
Mobile telecommunication 131, 141  
Movement detection system 85  
Multivariable predictive control 60

**N**

Negative temperature coefficient (NTC) 66  
Network(s) 9, 92, 93, 97, 100, 101, 135, 148  
    connectivity 97  
    industrial control 101  
    long-distance communication 101  
    neural 9  
    random-logic gate 92, 93  
    service providers 148  
    wireless 135  
Noise 95, 172

- level 172
  - mechanical 95
- O**
- Oil 18, 100, 113, 115
    - vegetable 113
    - refinery 18
  - Open loop system 23, 24, 60, 71
  - Operations 61, 64, 105
    - industrial 61
    - machining 105
    - milling 64
  - Oscillations 34, 35, 36, 41, 48, 71, 128, 129
  - Oscillator 109, 112, 154, 156
    - crystal 154
  - Oscillatory system 128
- P**
- Packaging system 3, 99, 102, 105, 106
  - Plastics, compress 159
  - PLC system 29
  - Pneumatic system 47
  - Pollution, environmental 153
  - Power 20, 62, 114, 116, 117, 118, 137, 142
    - boiler-based 62
    - consumption 142
    - source 114, 116, 117, 118, 137
    - system 20
  - Pressure 64, 113, 133, 187, 191
    - hydrostatic 133
    - sensor 64, 113, 187, 191
  - Printed 96, 115
    - circuit board (PCB) 96, 115
    - circuit board assembly (PCBA) 115
  - Process(s) 10, 29, 47, 105
    - isentropic 47
    - machining 105
    - planning, computer-aided 29
    - polytropic 47
    - technical 10, 29
  - Processing 3, 50, 57, 91, 96,
    - devices 3, 91
    - instructions 57
    - power 91
    - programming language 96
    - sensory 50
  - Processor 12, 69, 93, 94, 96, 97, 134
    - output variables 69
    - programmable digital 12
  - Programmable 3, 53, 91, 92, 94, 97, 109, 112, 135, 191
    - automation controller (PAC) 3, 53, 91, 97
    - logic devices (PLD) 3, 91, 92, 94
    - language 91, 109, 112, 135, 191
  - Programs 28, 55, 56, 92, 93, 94, 95, 96, 102, 103, 105, 116, 156, 159
    - artificial intelligent 103
  - Properties 137, 190
    - electrical conductivity 137
    - light-modulating 190
  - Prototype 131, 138, 155
    - automatic water level monitoring system 138
    - constructed water distribution system 131
  - Pump 139, 146, 147
    - design for selection 139
    - operating condition 146, 147
- R**
- Random access memory (RAM) 96
  - Renewable source 172
  - Resistance temperature detectors (RTDs) 39, 66
  - Robot 171, 175
    - control mechanism 171
    - hand gesture control 175
  - Robotic 11, 102, 161, 162, 163, 171, 172
    - process automation 11
    - situation 162
    - system 161, 163, 171, 172
    - technology 102
  - Robot(s) 21, 103, 104, 0162
    - artificial intelligent 104
    - domestic 21
    - industrial 21, 103
    - processes information 162
    - technology 162
- S**
- SCADA systems 95, 101
  - Semi-automatic control systems 80
  - Semiconductor 66
    - based sensors 66

## **Subject Index**

-based temperature sensors 66  
Sensors 31, 32, 39, 42, 46, 53, 61, 82, 92, 103,  
104, 108, 114, 116, 136, 144, 146, 147,  
161, 162, 163, 164  
flame 162, 163, 164  
measuring 146, 147  
Short-term fourier transform (STFT) 188  
Single input multiple output (SIMO) 79  
Smart water 135, 136  
distribution system (SWDS) 136  
management platform (SWMP) 135  
Software 11, 21, 97, 102, 106  
algorithms 97  
automation 11  
modelling 106  
program 102  
systems 21  
Soil moisture sensor 109, 110  
Spring 126  
constant 126  
force 126  
Stainless steel material 114  
Submersible pump 131, 133, 138, 139, 145,  
146, 148  
Suspension 108, 122, 124, 126, 127, 128, 129  
deflection 126  
system 108, 122, 124, 127, 128, 129  
System's 2, 12, 50, 53, 94, 108  
automation 2, 12, 50, 94, 108  
sensor 53

## **T**

Tactile sensors 103  
Techniques, echo resounding 177  
Temperature 31, 37, 39, 66, 70, 82, 114, 116,  
136, 162, 196  
sensor 31, 37, 66, 70, 82, 114, 116, 136,  
162, 196  
transmitter 39  
Trajectory pathway 174  
Transesterification 113  
Transportation systems 57

## **U**

Ultrasonic sensor 111, 112, 116, 136, 137,  
152, 154, 156, 163

## **Principles of Automation and Control 203**

## **V**

Variable frequency drive (VFD) 32  
Variations, microscopic 189  
Vehicles, robotic 74  
Voltage source 154

## **W**

Washing machine 23, 62, 68, 95  
automatic 68  
Waste(s) 111, 112, 152, 153, 156, 157, 158  
components 152, 153  
domestic 156, 157  
food 157  
house 153  
management 158  
metallic 157, 158  
plastic 158  
products 153  
Water 132, 133, 134, 135, 136, 145, 148,  
distribution systems 133, 148  
flow sensor 135, 136  
level sensors 145, 148  
management process 135  
management systems 135  
pollution 136  
pump 132, 135  
-related diseases 132, 133  
resource recovery 134  
Water pumping 132, 133, 137, 145  
machine 137  
Wireless system 181

## **Z**

Ziegler-Nichols method 84