

VOLTAMMETRY FOR SENSING APPLICATIONS

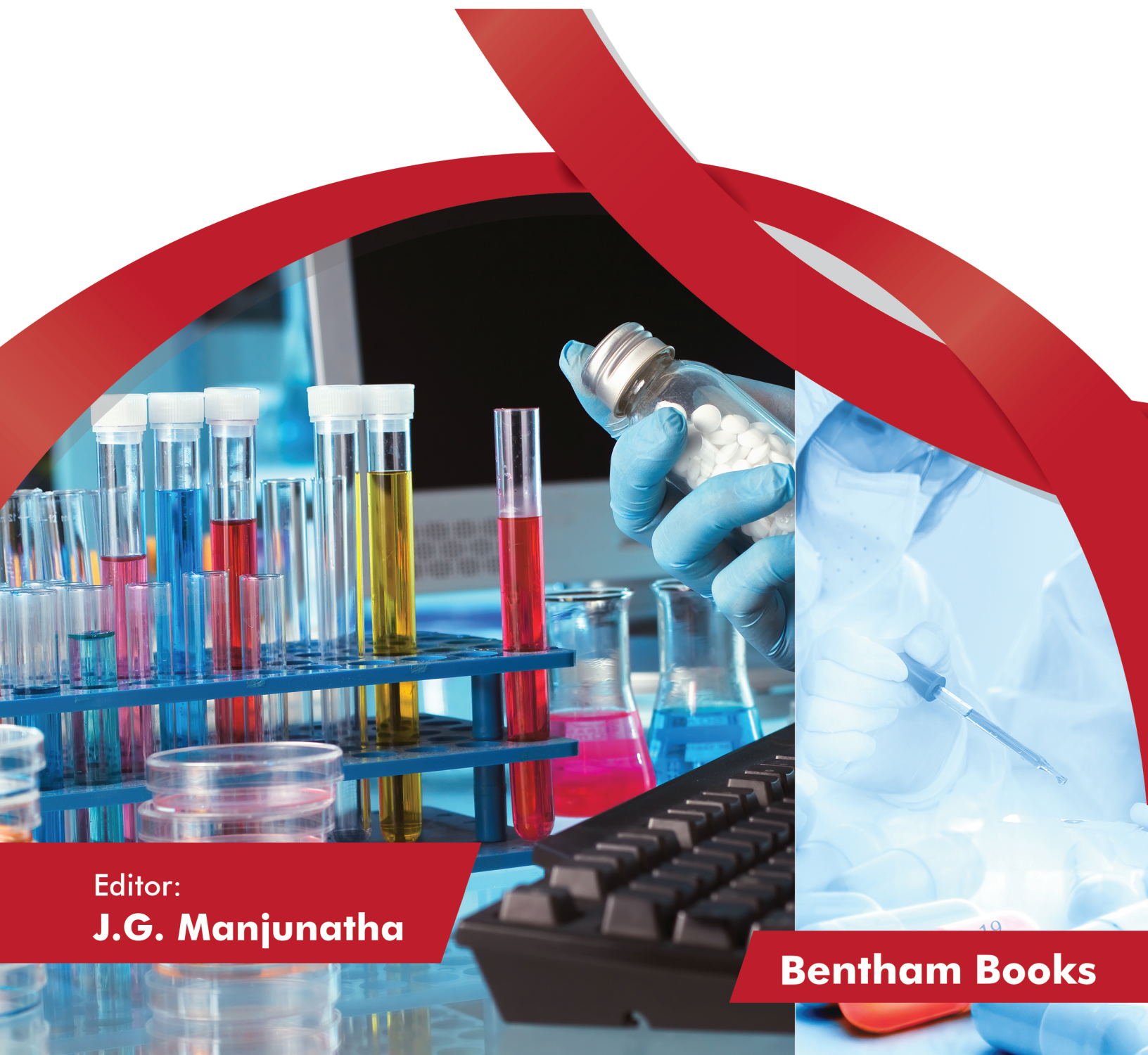

Editor:
J.G. Manjunatha

Bentham Books

Voltammetry for Sensing Applications

Edited by

J.G. Manjunatha

*Department of Chemistry,
FMKMC College, Madikeri,
Constituent College of Mangalore University,
Karnataka, India*

Voltammetry for Sensing Applications

Editor: J.G. Manjunatha

ISBN (Online): 978-981-5039-71-9

ISBN (Print): 978-981-5039-72-6

ISBN (Paperback): 978-981-5039-73-3

© 2022, Bentham Books imprint.

Published by Bentham Science Publishers Pte. Ltd. Singapore. All Rights Reserved.

BENTHAM SCIENCE PUBLISHERS LTD.

End User License Agreement (for non-institutional, personal use)

This is an agreement between you and Bentham Science Publishers Ltd. Please read this License Agreement carefully before using the book/echapter/ejournal (“**Work**”). Your use of the Work constitutes your agreement to the terms and conditions set forth in this License Agreement. If you do not agree to these terms and conditions then you should not use the Work.

Bentham Science Publishers agrees to grant you a non-exclusive, non-transferable limited license to use the Work subject to and in accordance with the following terms and conditions. This License Agreement is for non-library, personal use only. For a library / institutional / multi user license in respect of the Work, please contact: permission@benthamscience.net.

Usage Rules:

1. All rights reserved: The Work is the subject of copyright and Bentham Science Publishers either owns the Work (and the copyright in it) or is licensed to distribute the Work. You shall not copy, reproduce, modify, remove, delete, augment, add to, publish, transmit, sell, resell, create derivative works from, or in any way exploit the Work or make the Work available for others to do any of the same, in any form or by any means, in whole or in part, in each case without the prior written permission of Bentham Science Publishers, unless stated otherwise in this License Agreement.
2. You may download a copy of the Work on one occasion to one personal computer (including tablet, laptop, desktop, or other such devices). You may make one back-up copy of the Work to avoid losing it.
3. The unauthorised use or distribution of copyrighted or other proprietary content is illegal and could subject you to liability for substantial money damages. You will be liable for any damage resulting from your misuse of the Work or any violation of this License Agreement, including any infringement by you of copyrights or proprietary rights.

Disclaimer:

Bentham Science Publishers does not guarantee that the information in the Work is error-free, or warrant that it will meet your requirements or that access to the Work will be uninterrupted or error-free. The Work is provided "as is" without warranty of any kind, either express or implied or statutory, including, without limitation, implied warranties of merchantability and fitness for a particular purpose. The entire risk as to the results and performance of the Work is assumed by you. No responsibility is assumed by Bentham Science Publishers, its staff, editors and/or authors for any injury and/or damage to persons or property as a matter of products liability, negligence or otherwise, or from any use or operation of any methods, products instruction, advertisements or ideas contained in the Work.

Limitation of Liability:

In no event will Bentham Science Publishers, its staff, editors and/or authors, be liable for any damages, including, without limitation, special, incidental and/or consequential damages and/or damages for lost data and/or profits arising out of (whether directly or indirectly) the use or inability to use the Work. The entire liability of Bentham Science Publishers shall be limited to the amount actually paid by you for the Work.

General:

1. Any dispute or claim arising out of or in connection with this License Agreement or the Work (including non-contractual disputes or claims) will be governed by and construed in accordance with the laws of Singapore. Each party agrees that the courts of the state of Singapore shall have exclusive jurisdiction to settle any dispute or claim arising out of or in connection with this License Agreement or the Work (including non-contractual disputes or claims).
2. Your rights under this License Agreement will automatically terminate without notice and without the

need for a court order if at any point you breach any terms of this License Agreement. In no event will any delay or failure by Bentham Science Publishers in enforcing your compliance with this License Agreement constitute a waiver of any of its rights.

3. You acknowledge that you have read this License Agreement, and agree to be bound by its terms and conditions. To the extent that any other terms and conditions presented on any website of Bentham Science Publishers conflict with, or are inconsistent with, the terms and conditions set out in this License Agreement, you acknowledge that the terms and conditions set out in this License Agreement shall prevail.

Bentham Science Publishers Pte. Ltd.

80 Robinson Road #02-00

Singapore 068898

Singapore

Email: subscriptions@benthamscience.net



CONTENTS

PREFACE	i
LIST OF CONTRIBUTORS	ii
CHAPTER 1 ADVANCED SENSOR MATERIALS FOR DRUG ANALYSIS	1
<i>Hanaa S. El-Desoky</i>	
INTRODUCTION	2
NANOMATERIALS APPLIED FOR NANOSENSORS	2
CLASSIFICATION OF NANOMATERIALS	3
NANOPARTICLES SYNTHESIS	3
Metal Nanostructures in Sensors	5
Metal Oxide Nanostructures in Sensors	6
Carbonaceous Nanostructures	11
Carbon Nanotubes in Sensors	12
Graphene in Sensors	19
Reduced Graphene Oxide	24
Metal-oxide-doped Reduced Graphene Oxide Composites	26
Heteroatom-doped Graphene as Sensing Material	30
Hybrid Material Based on Mesoporous Silica and Graphene	31
Activated Charcoal in Sensors	33
Metal-organic Frameworks Based Nanosensors	38
Polymer-based Nanosensors	41
Molecularly Imprinted Polymers	44
Green Synthesis of Nanoparticles	47
CONCLUSION	50
CONSENT FOR PUBLICATION	51
CONFLICT OF INTEREST	51
ACKNOWLEDGEMENT	51
REFERENCE	51
CHAPTER 2 FUNCTIONALIZED NANOMATERIAL-BASED ELECTROCHEMICAL SENSORS FOR POINT-OF-CARE DEVICES	64
<i>İsmail Mert ALKAÇ, Ramazan BAYAT, Muhammed BEKMEZCİ and Fatih ŞEN</i>	
INTRODUCTION	64
NANOMATERIALS	66
Carbon Nanotubes	66
Graphene Oxide and Graphene	69
Non-carbon Nanomaterials	70
Metallic Nanoparticles (Other materials)	70
Nanowire	70
Organic Polymer Conductive	71
Nanoparticles with Magnetic Properties	72
SENSORS	72
Biosensors	73
<i>Electrochemical Biosensors</i>	74
<i>Classification of Electrochemical Biosensor</i>	76
NANOMATERIAL-BASED ELECTROCHEMICAL SENSORS	78
Nanomaterial-based electrochemical sensors for Hydrogen Peroxide (H ₂ O ₂) Biosensor	78
Electrochemical Nanomaterial-based Sensors for the Identification of Neurochemicals in Biological Matrices	80

ELECTROCHEMICAL SENSORS FOR POINT-OF-CARE	81
Various Point-of-care Diagnostic Nanosensors	82
<i>Nano-biosensors for Point-of-Care detection of Cancer</i>	82
<i>Nano-biosensors for Point-of-Care in Diabetes</i>	83
<i>Nano-biosensors for Point-of-Care in Infectious Diseases</i>	85
<i>Nano-biosensors for Point-of-Care in Human Immunodeficiency Virus (HIV)</i>	87
<i>Electrochemical Detection of Nucleic Acids by nanosensors</i>	88
<i>Synthesis and Applications to the Development of Electrochemical Sensors in the</i> <i>Determination of Drugs and Compounds of Clinical Interest</i>	91
CONCLUSION	91
CONSENT FOR PUBLICATION	91
CONFLICT INTERESTS	92
ACKNOWLEDGMENT	92
REFERENCES	92
CHAPTER 3 VOLTAMMETRIC SENSORS FOR DIVERSE ANALYSIS	103
<i>Agnes Chinecherem Nkele and Fabian I. Ezema</i>	
GENERAL INTRODUCTION	103
USEFUL VOLTAMMETRIC ELECTRODES	106
CLASSIFICATIONS OF VOLTAMMETRIC SENSORS	109
APPLICATIONS OF VOLTAMMETRIC MATERIALS	111
CONCLUDING REMARKS	112
CONSENT FOR PUBLICATION	113
CONFLICT OF INTEREST	113
ACKNOWLEDGEMENT	113
REFERENCES	113
CHAPTER 4 METHYL ORANGE ELECTROPOLYMERIZED COMPOSITE CARBON PASTE ELECTRODE AS A SENSITIVE AND SELECTIVE SENSOR FOR THE ELECTROCHEMICAL DETERMINATION OF RIBOFLAVIN	117
<i>Amrutha B. Monnappa, J. G. Manjunatha, Aarti S. Bhatt, Akshatha Nemumoolya, Sharmila B. Medappa and Geethanjali N. Karthammaiah</i>	
INTRODUCTION	118
MATERIALS AND METHODS	119
Instrumentation	119
Chemicals and Solutions	119
Preparation of BCCPE and PMOMCCPE	120
RESULTS AND DISCUSSIONS	120
Surface Topography Studies by FESEM and EIS	120
Electrochemical Active Surface Area	121
Electrochemical Polymerisation of MO	122
Influence of Solution pH	123
Electrochemical Behaviour of RB at Various Carbon Paste Electrodes	123
Effect of Scan Rate	124
Effect of Concentration on Peak Current	125
Selectivity of PMOMCCPE for Determination of RB	127
Repeatability, Reproducibility, and Stability of PMOMCCPE	128
Pharmaceutical Sample Analysis	128
CONCLUSION	129
CONSENT FOR PUBLICATION	129
CONFLICT INTEREST	130
ACKNOWLEDGMENT	130

REFERENCES	130
CHAPTER 5 A MODIFIED NANOSTRUCTURED GD-WO₃, SENSING INTERFACE MORPHOLOGY, THEIR VOLTAMMETRIC DETERMINATION AND APPLICATIONS IN ADVANCED ENERGY STORAGE DEVICES	134
<i>Vinayak Adimule, Basappa C. Yallur, Debdas Bhowmik and Santosh S. Nandi</i>	
INTRODUCTION	135
EXPERIMENTATION	137
Materials and Methods	137
Synthesis of WO ₃ Nanostructures (Step 1)	137
REACTIONS	138
Gd Doping to WO ₃ Nanostructures (Step 2)	138
RESULTS AND DISCUSSIONS	139
X-ray Diffraction Pattern Studies	139
<i>Elemental Compositional Analysis of Gd-WO₃ NS</i>	140
SEM and Cross-sectional SEM Morphology	141
<i>X-ray Photoelectron Spectroscopic (XPS) Analysis</i>	143
CYCLIC VOLTAMMETRY EXPERIMENTATION FOR ADVANCED ENERGY STORAGE APPLICATIONS	145
Sample Preparation for Gd-WO ₃ NS (x = 2, 5, 10 wt. %)	145
Galvanostatic Voltammetric Charging and Discharging Studies (GCD)	145
Electrochemical Voltammetric Determination of Specific Capacitance	146
Relation Between Phase Angle and Time in Voltammetric Properties of Gd-WO ₃ NS	148
CONCLUSION	152
AUTHORS CONTRIBUTIONS	152
CONSENT FOR PUBLICATION	152
CONFLICT OF INTEREST	153
ACKNOWLEDGEMENTS	153
REFERENCES	153
CHAPTER 6 OPTIMISED VOLTAMMETRIC APPROACHES FOR CLINICAL SAMPLE ANALYSIS	158
<i>Gnanesh Rao, Raghu Ningegowda, B. P. Nandeshwarappa, Kiran Kumar Mudnakudu, Nagaraju M. B Siddesh and Sandeep Chandrashekharappa</i>	
INTRODUCTION	159
CLINICAL ANALYTES	159
Analysis of Clinical Analytes using Voltammetric Biosensor	160
CNT BIOSENSOR	161
Types Based on Functionalization	162
1. <i>Enzymatic Biosensor</i>	162
2. <i>Affinity Biosensors</i>	163
3. <i>Immunosensors</i>	163
Preparation of Carbon Paste Electrode	164
Future Perspective of Exosomal Analysis using Nanotube Biosensors in Personalised and Precision Diagnosis	165
ISOLATION METHODS	166
CONCLUSION	168
CONSENT FOR PUBLICATION	168
CONFLICT OF INTEREST	168
ACKNOWLEDGEMENT	168
REFERENCES	169

CHAPTER 7 RECENT ADVANCES ON ELECTROCHEMICAL SENSORS FOR DETECTION AND ANALYSIS OF HEAVY METALS	177
<i>Monima Sarma</i>	
INTRODUCTION	177
Metal-Based Nanomaterials as Electrochemical Sensors	183
Carbon Nanomaterials in Heavy Metal Electrochemical Sensing	191
Screen-Printed Electrochemical Sensors	198
Polymer-Based Electrochemical Sensors	201
Fuel Cell-Based Self-Powered Electrochemical Sensors	203
Biomaterials in Electrochemical Sensing of Heavy Metal Ions	204
CONCLUSION AND PERSPECTIVE	206
CONSENT FOR PUBLICATION	208
CONFLICT OF INTEREST	208
ACKNOWLEDGEMENTS	208
REFERENCES	209
CHAPTER 8 ELECTROCHEMICAL, SENSING AND ENVIRONMENTAL ASSESSMENTS OF CUFe₂O₄/ZnO NANOCOMPOSITES SYNTHESIZED VIA AZADIRACHTA INDICA PLANT EXTRACT	215
<i>B. S. Surendra, N. Raghavendra, H. P. Nagaswarupa, T. R. Shashi Shekhar and S. C. Prashantha</i>	
INTRODUCTION	216
EXPERIMENT	217
Synthesis of CuFe ₂ O ₄ nanoparticles and ZnO oxide	217
Synthesis of CuFe ₂ O ₄ -ZnO Nanocomposite	217
Characterization	218
Photocatalytic Activity Measurements of Organic Dyes by CZO NCs	218
RESULTS AND DISCUSSION	218
PXRD Analysis	218
MORPHOLOGY EXAMINATION	219
FT-IR Analysis	220
Nitrogen Adsorption-desorption Isotherm	221
Cyclic Voltammetry (CV) Studies	221
Photocatalytic Degradation	223
Mechanism of Photocatalytic Degradation	224
Kinetic Studies	224
CONCLUSION	225
CONSENT FOR PUBLICATION	226
CONFLICT OF INTEREST	226
ACKNOWLEDGEMENTS	226
REFERENCES	226
CHAPTER 9 ADVANCED SENSOR MATERIALS FOR THE SIMULTANEOUS VOLTAMMETRIC DETERMINATION OF ANTIHYPERTENSIVE DRUGS: AN OVERVIEW	230
<i>Carlos Alberto Rossi Salamanca-Neto, Bruna Coldibeli, Erison Pereira de Abreu, Gabriel Junquetti Mattos, Gabriel Rainer Pontes Manrique, Jessica Scremin, Natalia Sayuri Matunaga Campos, Débora Nobile Clausen and Elen Romão Sartori</i>	
INTRODUCTION	231
THE CURRENT APPLICATION OF ANTIHYPERTENSIVE AGENTS ON CARDIOVASCULAR EVENTS	231

Electrochemical Techniques and Instrumentation Applied to the Electroanalysis of Antihypertensive Drugs	233
Advanced Sensor Platforms for Simultaneous Determination of Antihypertensives	235
<i>Glassy Carbon Electrode</i>	236
<i>Carbon Paste Electrodes</i>	239
<i>Screen Printed Electrodes</i>	242
<i>Nitrogen-Containing Tetrahedral Amorphous Carbon</i>	243
<i>Boron-Doped Diamond Electrode</i>	244
ELECTROOXIDATION MECHANISMS OF THE ANTIHYPERTENSIVES	250
CONCLUDING REMARKS	251
CONSENT FOR PUBLICATION	251
CONFLICT OF INTEREST	251
ACKNOWLEDGEMENTS	251
REFERENCES	251
CHAPTER 10 VOLTAMMETRIC APPLICATIONS IN ANTI-INFLAMMATORY DRUG DETECTION	259
<i>B. P. Sanjay, D. N. VarunI, S. Sandeep, C. S. Karthik, A. S. Santhosh, P. MalluI and Nagaraja Sreeharsha</i>	
INTRODUCTION	259
CLASSIFICATION OF VOLTAMMETRY TECHNIQUES	260
Polarography	260
Cyclic Voltammetry	261
Differential Pulse Voltammetry (DPV)	262
Square-Wave Voltammetry	263
ELECTROCHEMICAL SENSORS	263
Application of the Electrochemical Method for the Detection of Non-steroidal Anti-inflammatory Drugs (NSAIDs)	264
<i>4-Aminoantipyrine (4-AAP)</i>	264
<i>Indomethacin (IND)</i>	266
<i>Diclofenac (DCF)</i>	269
Preparation of Real Sample	272
CONCLUSION	272
CONSENT FOR PUBLICATION	273
CONFLICT OF INTEREST	273
ACKNOWLEDGMENTS	273
REFERENCES	273
CHAPTER 11 VOLTAMMETRIC APPLICATIONS IN DRUG DETECTION: MINI REVIEW	281
<i>G. Krishnaswamy, G. Shivaraja, S. Sreenivasa and Aruna Kumar D. B.</i>	
INTRODUCTION	281
ELECTROCHEMICAL CHARACTERIZATION OF ANTIBIOTICS	283
ELECTROCHEMICAL CHARACTERIZATION OF ANALGESICS	290
ELECTROCHEMICAL CHARACTERIZATION OF ANTHELMINTIC DRUGS	294
ELECTROCHEMICAL CHARACTERIZATION OF ANTI-TUBERCULOSIS DRUGS ...	296
ELECTROCHEMICAL CHARACTERIZATION OF ANTI-CANCER DRUGS	298
CONCLUSION	300
CONSENT FOR PUBLICATION	300
CONFLICT OF INTEREST	300
ACKNOWLEDGEMENTS	300
REFERENCES	300

CHAPTER 12 VOLTAMMETRIC APPLICATION IN DETECTION OF ANTICANCER DRUG	306
<i>Shankar Ashok Itagi, M. H. Chethana, P. Manikanta, S. Sandeep, C. S. Karthik, A. S., Santhosh K. S. Nithin, Kumara Swamy N. K. and P. Mallu</i>	
INTRODUCTION	306
METHOTREXATE	308
5-FLOUROURACIL	310
DOXORUBICIN	312
ETOPOSIDE	314
Preparation of Real Sample	316
CONCLUSION	317
CONSENT FOR PUBLICATION	317
CONFLICT OF INTEREST	317
ACKNOWLEDGMENTS	317
REFERENCES	318
CHAPTER 13 VOLTAMMETRIC STUDIES OF DYES AND THEIR ROLE AS CARBON ELECTRODE MODIFIERS	325
<i>Shefali Sharma¹, Anup Pandith², Shankamma Kalikeri³, Nagaraja Sreeharsha^{4,5} and Gururaj Kudur Jayaprakash^{1,*}</i>	
INTRODUCTION	325
PREPARATION OF ELECTRODES	327
ELECTROANALYSIS OF TEXTILE DYES	328
ELECTROANALYSIS OF MARKER DYES	330
BENEFITS OF ORGANIC DYE MODIFICATIONS	330
Organic Dyes Modification for Voltammetric Analysis of Dihydroxybenzene	331
Organic Dyes Modification for Voltammetric Analysis of Dopamine	333
Organic Dyes Modification for Voltammetric Analysis of Paracetamol	333
CONCLUSION	334
CONSENT FOR PUBLICATION	335
CONFLICT OF INTEREST	335
ACKNOWLEDGEMENT	335
REFERENCES	335
CHAPTER 14 ADVANCED VOLTAMMETRIC DEVICES FOR DISEASE DETECTION	339
<i>P. Sophiya, Deepadarshan Urs, Rajkumar S. Meti¹, H. A. Nagma Banu, J Shankar and K. K. Dharmappa</i>	
INTRODUCTION	339
PERSPECTIVE ON THE USAGE OF SENSORS IN DISEASE DETECTION	345
CONCLUSION	345
CONSENT FOR PUBLICATION	346
CONFLICT OF INTEREST	346
ACKNOWLEDGMENTS	346
REFERENCES	346
CHAPTER 15 ADVANCED MATERIALS FOR IMMUNE SENSORS	352
<i>A.H. Sneharani</i>	
INTRODUCTION	352
IMMUNE COMPLEX	353

IMMUNOSENSORS	355
CONCLUSION	363
CONSENT FOR PUBLICATION	363
CONFLICT OF INTEREST	363
ACKNOWLEDGEMENT	363
REFERENCES	363
SUBJECT INDEX	589

PREFACE

History has revealed that innovations in “Voltammetry for Sensing Applications” have been the significant approach in the advancement of electrochemical analysis in various platforms such as drug testing and analysis, sensors for point-of-care devices, sensors for diverse analysis, advanced energy storage devices, clinical sample analysis, sensors for the detection of heavy metals, nanomaterials, disease detection, immune sensors, food sample analysis, and anti-inflammatory and anticancer drug detection. The high significance, stability, repeatability, reproducibility, high performance, inexpensive, less time consuming, lower detection limit and quantification, and so on are the most appropriate applications for the sensing tools and methodologies and which portray an imperative character in the environment, biological, medicinal, and food safety-related analysis. Recently, a new era was commenced in voltammetry for sensing applications through the expansion of large-scale, sensitive, selective, and lower concentration level detection to create new sensing devices for giving a kinetic and electrochemical reaction phenomenon. Current advancements in sensing technology will authorize an advanced control in material physical and chemical characteristics and behavior. Hereby contributing an opportunity for new sensory materials in voltammetric analysis with progressive characteristics, such as greater reliability, low-cost, and improved steadiness.

J.G. Manjunatha

Department of Chemistry, FMKMC College, Madikeri,
Constituent College of Mangalore
University, Karnataka, India

List of Contributors

- A.H. Sneharani** DoS in Biochemistry, Jnana Kaveri P.G. Center, Mangalore University, Chikka Aluvara, Kodagu
- A S Santhosh** Department of Chemistry (UG), NMKRV College for Women, Jayanagar, Bengaluru – 560011, India
- Aarti S. Bhatt** Department of Chemistry, N.M.A.M. Institute of Technology, Visvesvaraya Technological University, Belgavi, Nitte, 574110, Udupi District, Karnataka, India
- Agnes Chinecherem Nkele** Department of Physics and Astronomy, University of Nigeria, Nsukka, Enugu, Nigeria
- Akshatha Nemumoolya** Department of Chemistry, FMKMC College, Madikeri, Constituent College of Mangalore University, Karnataka, India
- Amrutha B. Monnappa** Department of Chemistry, FMKMC College, Madikeri, Constituent College of Mangalore University, Karnataka, India
Department of Chemistry, N.M.A.M. Institute of Technology, Visvesvaraya Technological University, Belgavi, Nitte, 574110, Udupi District, Karnataka, India
- Anup Pandith** Department of Chemistry, School of Natural Sciences, KyungHee University, Seoul, South Korea
- Aruna Kumar D B** Department of Studies and Research in Organic Chemistry, Tumkur University, Tumakuru-572 103, Karnataka, India
- B P Sanjay** Department of Chemistry, JSS Science and Technology University, Mysuru- 570006, Karnataka, India
- B S Surendra** Department of Science, East West Institute of Technology, Bengaluru 560 091, Karnataka, India
- B. P. Nandeshwarappa** Department of PG Studies and Research in Chemistry, Shivagangothri, Davangere University, Davanagere, Karnataka - 577 007, India
- Basappa C Yallur** Department of Chemistry, M. S. Ramaiah Institute of Technology, Bangalore, Karnataka, India
- Bruna Coldibeli** Laboratório de Eletroanalítica e Sensores, Departamento de Química, Universidade Estadual de Londrina (UEL), Rodovia Celso Garcia Cid, PR 445 Km 380, Londrina – PR, C.P. 10.011, 86057-970, Brazil
- C S. Karthik** Department of Chemistry, JSS Science and Technology University, Mysuru- 570006, Karnataka, India
- Carlos Alberto Rossi Salamanca-Neto** Laboratório de Eletroanalítica e Sensores, Departamento de Química, Universidade Estadual de Londrina (UEL), Rodovia Celso Garcia Cid, PR 445 Km 380, Londrina – PR, C.P. 10.011, 86057-970, Brazil
- D N Varun** Department of Chemistry, JSS Science and Technology University, Mysuru- 570006, Karnataka, India

- Débora Nobile Clausen** Laboratório de Eletroanalítica e Sensores, Departamento de Química, Universidade Estadual de Londrina (UEL), Rodovia Celso Garcia Cid, PR 445 Km 380, Londrina – PR, C.P. 10.011, 86057-970, Brazil
Centro Universitário Cesumar (UniCesumar), Departamento de Biomedicina, Avenida Santa Mônica, 450, Londrina – PR, 86027-610, Brazil
- Debdas Bhowmik** High Energy Materials Research Laboratory, Defence Research and Development Organization, Ministry of Defence, Government of India, Sutarwadi, Pune, India
- Deepadarshan Urs** Department of Studies and Research in Biochemistry, Jnana Kaveri Post Graduate Centre, Mangalore University, Chikka Aluvara, Kodagu, Karnataka, India
- Elen Romão Sartori** Laboratório de Eletroanalítica e Sensores, Departamento de Química, Universidade Estadual de Londrina (UEL), Rodovia Celso Garcia Cid, PR 445 Km 380, Londrina – PR, C.P. 10.011, 86057-970, Brazil
- Erison Pereira de Abreu** Centro Universitário Cesumar (UniCesumar), Departamento de Biomedicina, Avenida Santa Mônica, 450, Londrina – PR, 86027-610, Brazil
- Fabian I. Ezema** Department of Physics and Astronomy, University of Nigeria, Nsukka, Enugu, Nigeria
Nanosciences African Network (NANOAFNET), iThemba LABS-National Research Foundation,, 1 Old Faure road, Somerset West 7129, P.O. Box 722, Somerset West, Western Cape Province, South Africa
UNESCO-UNISA Africa Chair in Nanosciences/Nanotechnology, College of Graduate Studies, University of South Africa (UNISA), Muckleneuk Ridge, P.O. Box 392,, Pretoria, South Africa
- Fatih ŞEN** Sen Research Group, Department of Biochemistry, University of Dumlupinar, 43000 Kütahya, Turkey
- G Krishnaswamy** Department of Studies and Research in Organic Chemistry , Tumkur University, Tumakuru-572 103, Karnataka, India
- G Shivaraja** Department of Studies and Research in Organic Chemistry , Tumkur University, Tumakuru-572 103, Karnataka, India
- Gabriel Junquetti Mattos** Laboratório de Eletroanalítica e Sensores, Departamento de Química, Universidade Estadual de Londrina (UEL), Rodovia Celso Garcia Cid, PR 445 Km 380, Londrina – PR, C.P. 10.011, 86057-970, Brazil
- Gabriel Rainer Pontes Manrique** Laboratório de Eletroanalítica e Sensores, Departamento de Química, Universidade Estadual de Londrina (UEL), Rodovia Celso Garcia Cid, PR 445 Km 380, Londrina – PR, C.P. 10.011, 86057-970, Brazil
- Geethanjali N. Karthammaiah** Department of Chemistry, FMKMC College, Madikeri, Constituent College of Mangalore University, Karnataka, India
- Gnanesh Rao** Department of Biochemistry, Bangalore University, Bangalore, Karnataka, India
- Gururaj Kudur Jayaprakash** School of Advanced School of Chemical Science, Shoolini University, Bajhol, Himachal Pradesh 173229, India

- H P Nagaswarupa** Department of Studies in Chemistry, Shivagangothri, Davangere University, Davangere - 577 007, Karnataka,, India
- Hanaa S. El-Desoky** Analytical and Electrochemistry Research Unit, Department of Chemistry, Faculty of Science, Tanta University, 31527 Tanta, Egypt
- J Shankar** Department of Studies and Research in Food Technology, Davangere University, Shivagangothri, Davangere, Karnataka, India
- Jamballi G. Manjunatha** Department of Chemistry, FMKMC College, Madikeri, Constituent College of Mangalore University, Karnataka, India
- Jessica Scremin** Laboratório de Eletroanalítica e Sensores, Departamento de Química, Universidade Estadual de Londrina (UEL), Rodovia Celso Garcia Cid, PR 445 Km 380, Londrina – PR, C.P. 10.011, 86057-970, Brazil
- K S Nithin** Department of Chemistry, The National Institute of Engineering, Mysuru, India
- K. K. Dharmappa** Department of Studies and Research in Biochemistry, Jnana Kaveri Post Graduate Centre, Mangalore University, Chikka Aluvara, Kodagu, Karnataka, India
- Kiran Kumar Mudnakudu-Nagaraju** Department of Biotechnology & Bioinformatics, Faculty of Life Sciences, JSS Academy of Higher Education and Research, Mysore 570015, Karnataka, India
- Kumara Swamy N k** Department of Chemistry, Sri Jayachamarajendra College of Engineering, JSS Science and Technology University, Mysuru, India
- M H Chethana** Department of Chemistry, Sri Jayachamarajendra College of Engineering, JSS Science and Technology University, Mysuru, India
- M. B Siddesh** Department of Chemistry, KLE'S S. K. Arts College and H. S. K. Science Institute, Hubballi, India
- Monima Sarma** Department of Chemistry, KL Deemed to be University (KLEF), Greenfields, Vaddeswaram, Andhra Pradesh 522502, India
- Muhammed BEKMEZCİ** Sen Research Group, Department of Biochemistry, University of Dumlupinar, 43000 Kütahya, Turkey
Department of Materials Science & Engineering, Faculty of Engineering, Dumlupinar University, Evliya Çelebi Campus, 43100 Kutahya, Turkey
- N Raghavendra** Department of Science, East West Institute of Technology, Bengaluru 560 091, Karnataka, India
- Natalia Sayuri Matunaga Campos** Laboratório de Eletroanalítica e Sensores, Departamento de Química, Universidade Estadual de Londrina (UEL), Rodovia Celso Garcia Cid, PR 445 Km 380, Londrina – PR, C.P. 10.011, 86057-970, Brazil
- Nagaraja Sreeharsha** Department of Pharmaceutical Sciences, College of Clinical Pharmacy, King Faisal University,, Al- Ahsa-31982, Saudi Arabia
Department of Pharmaceutics, Vidya Siri College of Pharmacy, Off Sarjapura Road, Bengaluru - 560035, Karnataka, India
- P Mallu** Department of Chemistry, Sri Jayachamarajendra College of Engineering, JSS Science and Technology University, Mysuru, India

P. Mallu	Department of Chemistry, JSS Science and Technology University, Mysuru- 570006, Karnataka, India
P Manikanta	Department of Chemistry, Sri Jayachamarajendra College of Engineering, JSS Science and Technology University, Mysuru, India
Raghu Ningegowda	Jyoti Nivas College Autonomous, Department of Studies in Chemistry, Bangalore-560095, India
Rajkumar S. Meti	Department of Studies and Research in Biochemistry, Jnana Kaveri Post Graduate Centre, Mangalore University, Chikka Aluvara, Kodagu, Karnataka, India
Ramazan BAYAT	Sen Research Group, Department of Biochemistry, University of Dumlupinar, 43000 Kütahya, Turkey Department of Materials Science & Engineering, Faculty of Engineering, Dumlupinar University, Evliya Çelebi Campus, 43100 Kutahya, Turkey
S C Prashantha	Department of Science, East West Institute of Technology, Bengaluru 560 091, Karnataka, India
S Sreenivasa	Department of Studies and Research in Chemistry, University College of Science, Tumkur University, Tumakuru-572 103, Karnataka, India Deputy Adviser, National Assessment and Accreditation Council, Bengaluru-560 072, Karnataka, India
S Sandeep	Department of Chemistry, JSS Science and Technology University, Mysuru- 570006, Karnataka, India
Sandeep Chandrashekhara	Institute for Stem Cell Science and Regenerative Medicine, NCBS, TIFR, GKVK-Campus Bellary road, Bengaluru 560065, Karnataka, India Department of Medicinal Chemistry, National Institute of Pharmaceutical Education and Research (NIPER) Raebareli, Lucknow (UP)-226002, India
Santosh S Nandi	Chemistry Section, Department of Engineering Science and Humanities, KLE Dr. M.S. Sheshgiri College of Engineering & Technology, Udhyambagh, Belagavi-590008, Karnataka, India
Shankar Ashok Itagi	Department of Chemistry, Sri Jayachamarajendra College of Engineering, JSS Science and Technology University, Mysuru, India
Shankamma Kalikeri	Division of Nanoscience and Technology, Department of Water and Health (Faculty of life sciences) JSS Academy of Higher Education & Research (Deemed to be University), Mysore-570015, India
Sharmila B. Medappa	Department of Chemistry, FMKMC College, Madikeri, Constituent College of Mangalore University, Karnataka, India
Shefali Sharma	School of Advanced School of Chemical Science, Shoolini University, Bajhol, Himachal Pradesh 173229, India
Sophiya P	Department of Studies and Research in Biochemistry, Jnana Kaveri Post Graduate Centre, Mangalore University, Chikka Aluvara, Kodagu, Karnataka, India
T R Shashi Shekhar	Department of Civil, East West Institute of Technology, Bengaluru 560 091, Karnataka, India

vi

İsmail Mert ALKAÇ

Sen Research Group, Department of Biochemistry, University of
Dumlupınar, 43000 Kütahya, Turkey
Department of Materials Science & Engineering, Faculty of Engineering,
Dumlupınar University, Evliya Çelebi Campus, 43100 Kutahya, Turkey

Vinayak Adimule

Department of Chemistry, Angadi Institute of Technology and
Management (AITM), Savagaon Road, Belagavi-5800321, Karnataka,
India

Advanced Sensor Materials for Drug Analysis

Hanaa S. El-Desoky^{1,*}

¹ Analytical and Electrochemistry Research Unit, Department of Chemistry, Faculty of Science, Tanta University, 31527 Tanta, Egypt

Abstract: Nanomaterials play an important role in the fabrication of many devices and modified materials, due to their unique properties, such as large surface area/volume ratio, conductivity and high mechanical strength. In the present chapter, the applicability of nanomaterials in drug analysis is well investigated. The recent trends in the development of the electrochemical sensor platforms based on state-of-the-art nanomaterials such as metal nanoparticles, metal oxide nanoparticles, carbon nanomaterials, conducting polymer and nanocomposites are discussed. The unique synthetic approaches, properties, integration, strategies, selected sensing applications and future prospects of these nanostructured materials for the design of advanced sensor platforms are also highlighted. Various kinds of functional nanocomposites have led to the enhancement in voltammetric response due to drug - nanomaterials interaction at the modified electrode surface. So, different mechanisms for the extraordinary and unique electrocatalytic activities of such nanomaterials will be highlighted. Potential applications of electrochemical sensor platforms based on advanced functional nanomaterials for drug analysis are presented. High sensitivity and selectivity, fast response, and excellent durability in biological media are all critical aspects which will also be addressed. It is expected that the chemically modified electrodes with various nanomaterials can be easily miniaturized and used as wearable, portable and user friendly devices. This will pave the way for in-vivo onsite real monitoring of single as well as multi-component pharmaceutical compounds. The significant development of the nanomaterials based electrochemical sensor platforms is giving rise to a new impetus of generating novel technologies for securing human and environmental safety.

Keywords: Analysis of drug, Biological fluids, Carbon nanotubes, Conducting polymer, Electrochemical sensor, Graphene, Hybrid nanostructure, Imprinted polymers, Metal nanoparticles, Metal oxide nanoparticles.

* Corresponding author Hanaa S. El-Desoky: Analytical and Electrochemistry Research Unit, Department of Chemistry, Faculty of Science, Tanta University, 31527 Tanta, Egypt; Tel: +201098846641; E-mails: hseldesoky@hotmail.com, hanaa_eldesoky@Science.tanta.edu.eg

INTRODUCTION

Nanotechnology involves the synthesis and application of materials having one of the dimensions in the range of 1–100 nm. The recent accomplishments in nanotechnology mainly nano-material-based electrochemical systems have led to the development of unique platforms that have significantly improved the sensory characteristics of conventional electrochemical systems. The combination of nano-materials of distinct nature and exceptional properties has notably contributed to fundamental biological research, environmental monitoring, drug and food safety, pharmaceutical procedures, healthcare diagnostics, and drug quality control. The interdisciplinary feature of such a synergic platform has not only extended the scope of sensor systems but has opened new pathways for the development of flexible and portable personal care and field applicable devices. Superior surface area to volume ratio and higher active site availability allow higher sensing response and catalysis as well as better magnetic, optical and electrical properties for biological, pharmaceutical and biomedical applications. This chapter mainly focuses on the modern advances in the growth of nanomaterials based electrochemical sensor platforms for the detection of potent biological analytes such as drugs and their ability for analysing complex samples such as urine, blood and pharmaceutical preparations.

NANOMATERIALS APPLIED FOR NANOSENSORS

Nanomaterials have unique physical and chemical properties as compared to their bulk materials due to their high surface area and electronic properties as well as the controlled morphology. The commonly used nanomaterials in electrochemical nanosensors are mainly carbon-based nanomaterials and metal oxide nanoparticles. Meanwhile, many emerging materials are explored to modify the surface of the working electrodes, such as conducting polymers [1], metal-based nanomaterials [2 - 4], carbon nanotubes [5 - 7], graphene [8 - 11], and metal-organic framework nanomaterials [12].

This leads to the development of electrodes with good stability, huge specific area, improved redox performance, and recyclability. The fabrication of the nanocomposites with many combinations such as; metal nanoparticles, metal oxide nanoparticles, carbon nanotubes (CNTs), graphene (GR), quantum dots, and conducting polymer further improve the electrochemical sensing properties of such electrodes [13]. Fig. (1) shows the schematic representation of the most important nanomaterials employed for biological and biomedical applications, especially drug analysis.

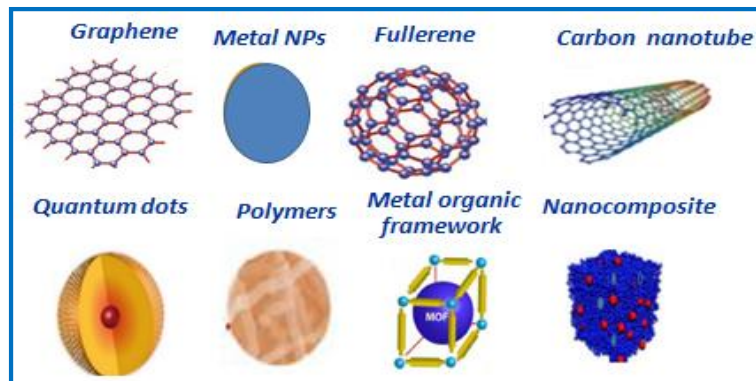

Fig. (1). Nanomaterials based electrochemical sensor platforms for drug analysis application.

CLASSIFICATION OF NANOMATERIALS

A simple classification of nano-materials based on their structures includes zero, one, two, and three dimensions. Fig. (2) presents some examples of various morphological structures of nano-materials. These nano-materials have many applications in electrochemistry, photochemistry, and biomedicine [14]. Nano-materials have many functional platforms which can be utilized for therapeutic functions.

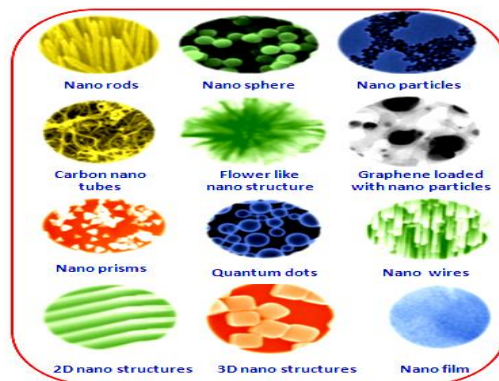

Fig. (2). Nanomaterials with various morphologies.

NANOPARTICLES SYNTHESIS

Several methods have been used for the synthesis of nanoparticles (NPs), including physical, chemical and biological methods [2, 4, 15 - 18] (Fig. 3). There are two different approaches for preparing the NPs; the bottom-up approach and the top-down approach. In the bottom-up approach, the atoms are assembled in nuclei and then grown into NPs. The top-down approach starts with bulk material

Functionalized Nanomaterial-Based Electrochemical Sensors for Point-of-Care Devices

İsmail Mert ALKAÇ^{1,2}, Ramazan BAYAT^{1,2}, Muhammed BEKMEZCİ^{1,2} and Fatih ŞEN^{1,*}

¹ Sen Research Group, Department of Biochemistry, University of Dumlupınar, 43000 Kütahya, Turkey

² Department of Materials Science & Engineering, Faculty of Engineering, Dumlupınar University, Evliya Çelebi Campus, 43100 Kutahya, Turkey

Abstract: Electrochemical sensors used for the detection of specific biomolecules have attracted great attention in recent years due to their high sensitivity, selectivity, simple preparation, and fast response. In recent years, the integration of biological components into analytical tools, especially in biomedical research, has become a prerequisite for the early diagnosis of many diseases. In addition, enabling early diagnosis and treatment of diseases provides improved health outcomes and rapid medical decision-making. Here, we present the classification of biosensors and general concept, materials used in electrochemical sensors, their advantages, disadvantages, and main strategies in electrochemical biosensor technology such as electrodes and supporting substrates, materials for the bioreceptor materials for improved sensitivity and selectivity. This book chapter is focused on the functionalization of nanomaterials developed in recent years aimed at electrochemical biosensors and their functionalization for point of care devices. The various point of care device examples have been tried to form an idea about the usage areas.

Keywords: Diagnosis, Electrochemical Sensors, Nanomaterial, Point-of-Care Devices.

INTRODUCTION

Stable, cost-effective, and reliable detection of specific biomolecules or chemical products is of great importance in medicine, the environment, and industry [1]. Electrochemical sensors are frequently studied and used for their fast response, high sensitivity, specificity, and accuracy. They are also used in the production of miniaturized portable systems for point of care [1].

* Corresponding author Fatih ŞEN: Department of Materials Science & Engineering, Faculty of Engineering, Dumlupınar University, Evliya Çelebi Campus, 43100 Kutahya, Turkey; E-mail: fatihsen1980@gmail.com

The production of electrochemical sensors is of great interest due to their high selectivity and sensitivity. It is increasingly used in industrial process monitoring, clinical diagnosis, analytical chemistry, environmental analysis, and food industries [2].

Biosensors are of interest to biomedical and pharmaceuticals due to their sensitivity, high selectivity, high cost/benefit ratios, specificity, simple use, fast data collection, and analysis [2].

The main advantages of biosensors over traditional analytical methods, which will lead to even more pronounced use in the biomedical field soon, are: analyte detection is often performed without prior separation; flexibility and simplicity of preparation; easy to use allows in-field or point-of-care (POC) measurements.; short possible response times of biological real-time monitoring and production processes; miniaturization and automation possibility; possibility of low production costs and mass production. The use of biosensors as components in medical devices has improved reliability in POC analysis and accessibility, portability, and real-time diagnosis [2].

Point of care testing facilitates disease diagnosis by providing rapid detection, monitoring, and management of analytes. Early diagnosis of the disease allows patients to start treatment early, allowing rapid medical decisions. Recently, several potential POC devices have been developed, leading to a new generation of POC tests [3].

Biosensors are directly responsible for bioanalytical performance and are critical components for POC devices because of these properties. They have therefore been investigated for forward-looking POC applications necessary for personalized healthcare management, as they predict and hence detect levels of disease-causing chemical reactions or biological markers, such as body fluids, by generating signals often associated with the concentration of an analyte. Their high sensitivity and selectivity allowed treatment of targeted diseases and early diagnosis. Therefore, in combination with timely treatment decisions, nanotechnology can improve the diagnosis and assessment of disease progression and facilitate treatment planning for many diseases [3].

Recently, various electrochemical biosensing methods have been miniaturized devices for *in situ* analysis and developed for simplicity. Besides, the high repeatability and sensitivity of the biosensor remain a challenge. The use of functional nanomaterials for a matrix to amplify signal amplification and high-performance electrochemical analysis draw attention [4]. Nanomaterials (NMs) have a wide surface area, resulting in a synergistic effect for signal amplification by supporting increased loading capacity and bulk transport of reactants [5].

Taking advantage of exceptional features such as being easy to use, economical, sensitive, portable and simple to make, great importance has been focused on the integration of recognition elements with electronic elements to develop electrochemical biosensors. Besides, the high repeatability and sensitivity of the biosensor remain a challenge. The use of functional nanomaterials for a matrix to amplify signal amplification and high-performance electrochemical analysis gained much attention.

The creation of new transmission networks of NMs, biosensors (sub-class electrochemical sensors) provide superior catalytic activity and strong paramagnetic properties and signal enhancement capabilities.

NANOMATERIALS

In the last decade, there has been a great development in nanotechnology due to the improvement in nanomaterials (NMs), including metallic and magnetic nanoparticles and carbon nanomaterials [6]. NMs commonly defined as materials with dimensions less than 100 nm have a large application area due to their small size properties (improved chemical reactivity, electrical conductivity, and tensile strength) achieved with increased surface area per unit weight [2].

Nanoparticles (NPs) are high sensitivity (thousands of atoms can be released from a nanoparticle), very stable (compared to enzyme labels), have large varieties of NPs, and are available on the market. NMs are mainly used as biomolecule tracer or electrode making. Nanoparticles are used today as electrochemical tags, as tools with hundreds or thousands of electroactive labels, reducing the limits of detection to several hundred biomolecules [7].

Carbon Nanotubes

As effective electrode materials, carbon nanotubes (CNT) have been used extensively for electrochemical sensing platforms. CNTs have a high electrocatalytic operation due to excellent electron transfer capabilities, ideal structural characteristics, wide surface areas, mechanical, electrical properties, and high sensitivity. NTs exhibit a high degree of immobilization of bio-recognition elements such as enzymes, aptamers, antibodies, imprinted polymers [8].

There are two types of CNTs; the first one is multi-walled carbon nanotubes (MWCNTs) and the other one is single-walled carbon nanotubes (SWCNT). Graphene, a 2-D hexagonal carbon atom model, is also used as an electrode due to its higher specific surface area than CNTs [9]. Graphene oxide (GOx) resolves

Voltammetric Sensors for Diverse Analysis

Agnes Chinecherem Nkele¹ and Fabian I. Ezema^{1,2,3,*}

¹ Department of Physics and Astronomy, University of Nigeria, Nsukka, Enugu, Nigeria

² Nanosciences African Network (NANOAFNET), iThemba LABS-National Research Foundation, 1 Old Faure road, Somerset West 7129, P.O. Box 722, Somerset West, Western Cape Province, South Africa

³ UNESCO-UNISA Africa Chair in Nanosciences/Nanotechnology, College of Graduate Studies, University of South Africa (UNISA), Muckleneuk Ridge, P.O. Box 392, Pretoria, South Africa

Abstract: Voltammetric techniques are widely used in detecting and diagnosing the electrochemical properties of electrode systems. These techniques adopt sensing devices that find relevance in analyzing water, studying biological systems, tracing poisonous chemicals, *etc.* These sensors have different compositions that aim at carrying out different functions in diverse systems. The sensors would be useful in biological, environmental, and chemical systems. In-depth knowledge of voltammetric sensors will be discussed. This chapter will also highlight different sensors, independent features, sensor classifications, voltammetric electrodes, and their areas of application.

Keywords: Electrochemical properties, Electrode, Sensors, Voltammetry.

GENERAL INTRODUCTION

Voltammetry is an electrochemical process that involves measuring current when an alternating voltage passes through the working electrode [1]. The potential applied depends on time because the current is measured with respect to the potential. It is a commonly used method in detecting and diagnosing the electrochemical characteristics of a system of electrodes. The use of biological and chemical sensors in determining contaminants within an environment has become an interesting study area. Such sensors have a quick response time, a small limit for detection, and on-site usage [2]. The conductivity of the working electrode is an important element that increases the electron mobility and sensi-

* **Corresponding author F. I. Ezema:** Department of Physics and Astronomy, University of Nigeria, Nsukka, Enugu, Nigeria and Nanosciences African Network (NANOAFNET), iThemba LABS-National Research Foundation, 1 Old Faure road, Somerset West 7129, P.O. Box 722, Somerset West, Western Cape Province, South Africa; E-mail: fabian.ezema@unn.edu.ng

vity of the biosensor. Voltammetry significantly minimizes the number of harmful chemicals obtainable from the use and disposal of materials. Voltammetry incorporates materials like silver, nickel, platinum, copper, and gold because of its wide potential range and increased electron mobility. Platinum is commonly used as the auxiliary electrode while silver/silver chloride serves as the reference electrode. The shape of cyclic voltammograms is affected by anions present. Introducing surfactants reduces the amount of faradaic current available. Stripping is an important class of voltammetry that is useful in electroanalytical chemistry, involves relatively cheap pieces of equipment, is capable of analyzing different elements, and is highly sensitive [3]. It has low detection limits due to the accumulation of the analyte on the working electrode. Metals can be analyzed by stripping method in the absence of contaminants obtainable from electrolytes. Anodic stripping voltammetry (ASV), cathodic stripping voltammetry (CSV), adsorptive stripping voltammetry (ADSV), and catalytic ADSV are advanced forms of stripping voltammetry that effectively and quantitatively analyze inorganic anions, transition metals, organic molecules, *etc* [2]. For Anodic SV; anodic currents are obtained by undertaking a preconcentration step at the cathode and taking a voltage scan towards the positive range [3]. The reverse occurs for the cathodic stripping voltammetry. Voltammetry of microparticles is a valuable method to study the corrosive nature of archaeological metals by understanding their source and authenticity [4]. Studying nanoparticles using voltammetry can also be useful for data collection and mapping. Electrochemical cells used in voltammetry can be produced in various sizes and give room for solutions to be analyzed. They include a working electrode, auxiliary electrode, reference electrode, optional bar for stirring, and a nitrogen purge line for oxygen removal, as shown in Fig. (1). At the working electrode, oxidation of the analyte occurs and minimizes the solvent by transporting the resultant electrons to the auxiliary electrode through the potentiostat. Reducing the quantity of analyte at the working electrode causes current (Faradaic current) to flow to the cathode from the auxiliary electrode. Diffusion, migration, and convection are important factors that affect the rate of mass transport. The current flowing through voltammetric cells is affected by the rate of mass transport and electron mobility.

Coulometry and amperometry are useful forms of voltammetry, with coulometry exhibiting better sensitive capabilities [5]. A steady voltage is applied to the working electrode in amperometry as the current is measured with time, as represented in Fig. (2). The kind of voltammetric technique to be adopted depends on properties of the material like its position and concentration, kind of precision and accuracy required.

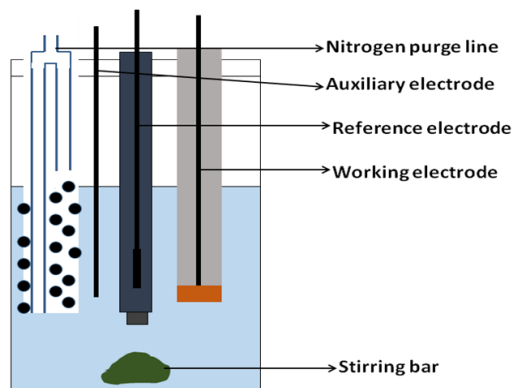

Fig. (1). Schematic diagram for a voltammetric electrochemical cell.

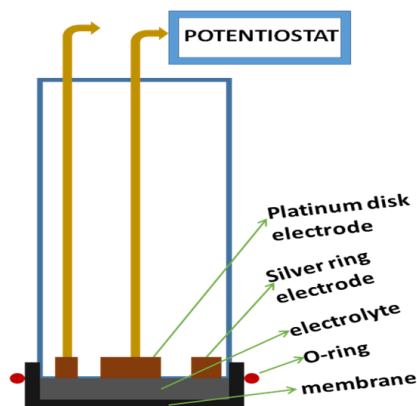

Fig. (2). Schematic representation of the amperometric sensor used to determine dissolved oxygen.

Cyclic voltammetry is a common form of voltammetry that records cyclic voltammograms through a scan in both directions and is carried out within a short time frame [6 - 11]. It estimates the activities of biocatalysts at the anode when subjected to various operating conditions [1]. Another measurement approach known as hydrodynamic voltammetry measures current as a differential pulse or linear scan, as mercury drops grow without oscillation. Voltammograms (current and applied potential plot) obtained from voltammetry provide meaningful information on the species undergoing reduction or oxidation [12, 13]. During the adsorption of redox species on an electrode, cyclic voltammograms, as seen in Fig. (3) [14], could be obtainable. The redox centers in Fig. (3A) get reduced at electrode potentials that are lower than E° . At higher potential values, oxidation occurs as the electrode and reduction potentials meet (Fig. 3B). At increased potential, a measured positive current reduces to zero and oxidation occurs (Fig. 3C). The manner of current measurement and inclusion of convection in mass transport affects the shape of the voltammogram.

CHAPTER 4

Methyl Orange Electropolymerized Composite Carbon Paste Electrode as a Sensitive and Selective Sensor for the Electrochemical Determination of Riboflavin

Amrutha B. Monnappa^{1, 2}, J. G. Manjunatha^{1,*}, Aarti S. Bhatt², Akshatha Nemumoolya¹, Sharmila B. Medappa¹ and Geethanjali N. Karthammaiah¹

¹ Department of Chemistry, FMKMC College, Madikeri, Constituent College of Mangalore University, Karnataka, India

² Department of Chemistry, N.M.A.M. Institute of Technology, Visvesvaraya Technological University, Belgavi, Nitte, 574110, Udupi District, Karnataka, India

Abstract: Riboflavin (RB) is a vital B group water soluble vitamin. RB is essential for all animals and humans. This essential constituent of flavoenzyme, which plays an important role in biochemical reactions, is investigated by Cyclic voltammetry (CV) and Differential pulse voltammetry (DPV) using Poly methyl orange modified composite carbon paste electrode (PMOMCCPE). RB exhibits an oxidation peak with the highest anodic current of 54.82 μA at a potential of -0.4360 V in 0.2 M phosphate buffer solution (PBS) with a pH value of 7.5. The surface topography studies of fabricated PMOMCCPE were carried out by CV, Field emission scanning electron microscopy (FE-SEM) and Electronic impedance spectroscopy (EIS). Optimization of pH and polymer cycle was carried out, and the effect of scan rate was also studied. The anodic peak current obtained is linearly related to the variations in the concentration of RB in the range 4 to 50 μM . Other features include a detection limit of $1.67 \times 10^{-7}\text{ M}$, and good reproducibility, repeatability and stability. Simultaneous determination of RB with dopamine (DA) was done and interferences by some potentially interfering compounds were tested. PMOMCCPE was successfully used for determining RB in pharmaceutical formulations which gave recoveries in the range from 96.50 to 99.53%.

Keywords: Anodic peak current, Composite carbon paste electrode, Cyclic voltammetry, Differential pulse voltammetry, Dopamine, Riboflavin.

* Corresponding author J. G. Manjunatha: Department of Chemistry, FMKMC College, Madikeri, Constituent College of Mangalore University, Karnataka, India; E-mail: manju1853@gmail.com

J.G. Manjunatha (Ed.)

All rights reserved-© 2022 Bentham Science Publishers

INTRODUCTION

RB is found in a variety of foods and dissolves in water. In 1879, RB was first isolated from milk as an impure form and it was named lactochrome. It crystallises as orange-yellow crystals and has a low water solubility in its pure form [1]. RB or vitamin B₂ is a B group vitamin and an important constituent of flavoenzymes, which plays a significant role in the biochemical reactions in the human body. It's the major component of flavin adenine dinucleotide (FAD) and flavin mononucleotide (FMN), and it's required for a range of flavoprotein enzyme activities, including vitamin activation. Its deficiency is connected with eye lesions and skin disorders. RB cannot be formed in the human body, so it must be obtained from food like liver, cheese, fruits, vegetables and pharmaceutical products [2]. RB is commonly used in combination with other members of the vitamin B group in B-complex products. In organisms, RB serves as a hydrogen carrier during redox reactions that affect carbohydrate, protein, fat and haemoglobin synthesis, as well as enables the preservation of visual function [3].

Several researchers have worked hard to analyse RB using various analytical processes, with the electroanalytical method proving to be the most advantageous due to its simple, quick, and cost-effective instrumentation. Chemically modified carbon-based electrodes are an excellent method for improving sensor performance. Carbon nanotubes (CNT), also known as buckytubes, are composed of a concentric arrangement of several cylinders, which have unique properties with promising applications in the field of nanotechnology. CNTs have unique electrical and optical features that distinguish them from other carbonaceous materials and nanoparticles of other sorts due to their outstanding one-dimensional nanostructures. CNTs are widely used in electronic and optoelectronic, biomedical, pharmaceutical, energy, catalytic, analytical, and material fields [4 - 6]. Carbon paste electrodes (CPE) have been widely utilised for many years due to their non-hazardous behaviour, low cost, and ease of availability. It is used for the fabrication of various biosensors and electrochemical sensors. CPEs are the most preferred electrode material due to their advantageous qualities such as low mass density, heat resistance, chemical tolerance, low residual current throughout the entire potential range, and ease of electrode surface modification [7 - 9]. Hence, in the present work CNTs and carbon powder in the composite form are homogenised in silicone oil as the sensitive sensing material. These composite electrodes, due to their beneficial properties like enlarged surface area and ability to boost the rate of electron transfer, improvise the electrocatalytic nature of the sensor.

Surface modification of these composite electrodes by azo dyes is effectually done using electro polymerisation technique, where the polymer forms a consistent deposition of polymer film on the composite carbon paste electrode [10, 11]. Azo dyes, which are commonly used in science, medicine, food, and the textile industry, can be used to modify electrode surfaces in a variety of ways. Methyl orange is an organic dye which has both hydrophilic as well as hydrophobic groups, and a molecular cavity. It's an acidic, aromatic synthetic dye that's widely used in textiles, leather, petroleum, the food industry, and pharmaceuticals as a colouring agent [12, 13]. In this chapter, methyl orange is electropolymerized on a composite carbon paste electrode surface for the enhanced voltammetry determination of RB.

MATERIALS AND METHODS

Instrumentation

Electrochemical work station CHI-6038E model (CH Instrument-6038 electrochemical workstation-USA) was used to conduct electrochemical experiments at lab temperature. The electrochemical cell was set up with an ideal tri electrode system consisting of BCCPE and PMOMCCPE as working electrodes, KCl saturated calomel and platinum counter electrode. The instrument working at 5.00 kV from DST-PURSE Laboratory, Mangalore University, was used to perform FE-SEM.

Chemicals and Solutions

Carbon nanotube (30-50 nm and a length of 10-30) was bought from Sisco research laboratories, Mumbai. Carbon powder, Silicone oil and Potassium chloride were procured from Nice Chemicals (Cochin) India. Mono sodium dihydrogen phosphate, disodium hydrogen phosphate and l-leucine were obtained from Himedia chemicals (India), RB and DA were obtained from Molychem laboratory, India. 25×10^{-4} M RB was prepared by dissolving the required quantity in sodium hydroxide and DA stock solution was prepared by dissolving the essential amount of solute in double distilled water. 25 mM stock solution of MO was prepared by suspending the required amount of solute in double distilled water. Appropriate quantity of 0.2 M Na_2HPO_4 and 0.2 M NaH_2PO_4 were intermixed to prepare 0.2 M Phosphate buffer solution (PBS) of different pH values. Real sample solution was prepared by weighing the appropriate quantity of RB samples commercially available and was dissolved in an amber coloured volumetric flask with double distilled water to get a standard solution of 25×10^{-4} M strength.

A Modified Nanostructured Gd-WO₃, Sensing Interface Morphology, their Voltammetric Determination and Applications in Advanced Energy Storage Devices

Vinayak Adimule^{1,*}, Basappa C. Yallur², Debdas Bhowmik³ and Santosh S. Nandi⁴

¹ Department of Chemistry, Angadi Institute of Technology and Management (AITM), Savagaon Road, Belagavi-5800321, Karnataka, India

² Department of Chemistry, M. S. Ramaiah Institute of Technology, Bangalore, Karnataka, India

³ High Energy Materials Research Laboratory, Defence Research and Development Organization, Ministry of Defence, Government of India, Sutarwadi, Pune, India

⁴ Chemistry Section, Department of Engineering Science and Humanities, KLE Dr. M.S. Sheshgiri College of Engineering & Technology, Udhyambagh, Belagavi-590008, Karnataka, India

Abstract: Perovskite electrodes can be a pertinent method to enhance electrochemical voltammetric sensing performances. In the present research, Gd_xWO₃ (x = 2, 5, 10 wt. %) nanostructures (NS) are synthesized by a facile co-precipitation method, calcinated at 750-800 °C and subsequently fabricated using electron beam deposition method over glass substrate used for electrochemical voltammetric determination. Scanning electron microscopy and X-ray diffraction were employed to examine the crystal phase and morphology of the gadolinium doped nanostructures thus prepared. Surface chemical composition, chemical bond analysis, dispersion of Gd into WO₃ were confirmed by XPS (X-ray photoelectron spectral) studies. SEM (scanning electron microscopy) micrographs showed flake-like surface morphology can act as sensing interface for facile transfer of electrons over NS of Gd_xWO₃, and SEM cross section micrographs revealed agglomerated densely packed rod like structure. Gd_xWO₃ nanostructure showed ~ 89 nm grain, ~ 110 nm grain boundary distances, UV-visible absorptivity maxima observed between 280 nm to 340 nm for Gd_xWO₃ NS. Electrochemical cyclic voltammetry performance was tested in three electrodes assembled for high performance energy storage applications, involving cyclic voltammetric charge discharge cycles and sensing interface between fabricated NS, and cyclic voltammetry carried out in 6M KOH solution. Gd_xWO₃ demonstrates a specific capacitance of 450 F/g at a current density of 0.1 A/g. Gd-WO₃ NS has a capacitance retention rate of 88.5% after 5,000 cycles (cyclic stability). Voltammetric characteristics indicate that

* Corresponding author Dr. Vinayak Adimule: Department of Chemistry, Angadi Institute of Technology and Management (AITM), Savagaon Road, Belagavi-5800321, Karnataka, India; E-mail: adimulevinayak@yahoo.in

Gd_xWO₃ NS is a promising electrode material for energy storage devices and can be used as high-performance super capacitor applications.

Keywords: Agglomeration, Charge-Discharge, Co precipitation, Cyclic stability, Cyclic Voltammetry, Electrochemical voltammetry, Energy storage devices, Gd-WO₃, Inorganic Nanostructures, Morphology, Nanoparticles, Nanostructures, Sensing, SEM, Specific Capacitance, Super capacitor, Synthesis, UV-Visible, XRD, XPS.

INTRODUCTION

In recent years, damage has been done to the environment and their subsequent causes such as gas greenhouse gas emission, air pollution, this necessitates better eco-friendly, cleaner energy sources. In this perspective, batteries and fuel cells were investigated and made use of as a viable options. However, disadvantages (lower power efficiency, high cost, low-rate capabilities, *etc.*) in the energy sources of batteries and fuel cells are envisaged for the development of new energy storage devices. Increasing demand for high energy devices in consumer electronics, portable electronics, electric vehicles, *etc.*, to fulfil the void and unleash energy storage super capacitors are widely attempted [1 - 3]. In general, super capacitor segmented into two main categories one is (EDLC) and another is pseudo capacitor [4]. EDLCs commonly use carbon containing materials such as graphene, carbon nanotubes (CNTs), reduced graphene oxide (rGO), having a large surface area, higher charge discharge cycles and high-power density. Structural morphology is maintained for a quite long period of time, which is due to adsorption and desorption of ions over the surface of the electrode. On the other hand, pseudo capacitors consist of transition metal oxides (ZnO, Gd₂O₃, Y₂O₃, CeO₂, *etc.*) and charge discharge cycles appear due to redox reactions occurring in the system. Electrochemical approaches offer practical benefits in addition to satisfactory sensitivity, wide linear concentration range, operation simplicity, the possibility of miniaturization, low expense of instruments, suitability for real-time detection and less sensitivity to matrix effects in comparison with spectral and separation methods. Recently, rare earth elements used as dopants have shown many potentials in enhanced microwave absorption, photoluminescence and photocatalytic activity.

Tungsten oxide (WO₃) is one of the interesting materials because it is highly stable, low-cost, eco-friendly, less toxic, and widely used as a pseudo capacitor material which has grasped much attention of the scientific community due to unique characteristic features such as being used in electrochromic devices, energy harvesting devices, enhanced I-V/C-V characteristics, photovoltaic, *etc.* [5 - 9]. Tungsten oxide (WO₃) as high-performance energy storage materials and

their characteristic features published in recent years [10]. More recently, numerous reports were published for synthesis, characterization of WO_3 nanostructure, which includes chemical co-precipitation, vapour deposition, spray pyrolysis, *etc* [11 - 14]. Due to the small radius and desirable crystal structure of the hexagonal WO_3 NS, a prominent influence on the desired electrochemical performance was observed. The structural and morphological changes in the WO_3 NS were successively studied for photochromic properties by Huang *et al.* [15]. Similarly, Nagy *et al.* studied the effect of structural morphology variations and characterized them with respect to dependency in pH of the solution. Many researchers studied the photo catalytic efficiency of the WO_3 nanoparticles [16, 17]. Kalhori *et al.* synthesized flower shaped two different phases of WO_3 NS, one is orthorhombic and another is monoclinic by varying hydrothermal temperature. The precursor used was ammonium oxalate and WO_3 NS was studied for gas chromic responses [18]. WO_3 NS in crystalline nature possesses greater stability due to slower dissolution rate and denser accumulation of nanoparticles. As for WO_3 , doping elements reported were mainly focused on transition metals such as Mo, Ni, Ti, V, Nb, Fe, Ru, *etc.*, by which the improvements both in ionic conductivity and high energy storage devices have been obtained mainly because of the introduction of oxygen vacancies. More recently, we have shown that gadolinium (Gd) doping can effectively improve the high energy storage device of the sputtered amorphous WO_3 . Luminescent properties of Ta doped WO_3 NS having smooth crystallinity, moderate band gap and blue line emission in photoluminescence spectra. All the films showed 80% optical transference in the wavelength of 400 nm to 900 nm with increased optical reflectance [19]. A novel set of Ag doped WO_3 NS synthesized by hydrothermal method, heterostructure showed increased gas response towards 100 ppm of formalin (HCHO) almost 3.5 times higher response and recovery time was 3s/3s respectively [20]. PtCl_2 coated WO_3 NS deposited by hydrogen reduction of metal salts finds gas chromic application at 90 °C and becomes insignificant at temperatures below 90 °C [21]. Photocatalysis of nitrite ions under visible light performed for the Zn doped WO_3 nanostructure Enhanced Photo electrocatalysis illustrated highest degradation of nitrite ions for 2% Zn- WO_3 NS annealed at 400 °C [22]. A novel class of Tb- WO_3 NS fabricated using Radio Frequency (RF) magnetron sputtering technique shows porous nature of Tb^{+3} ions heavily doped exhibit strong blue, green and red emissions under UV excitation which suggest the possibility of using these luminescent films in white light emitting devices [23]. Enhanced photo electrochemical properties of Bi doped WO_3 NS synthesized through hydrothermal method, displayed remarkable enhancement in photocurrent values from 0.401 mA cm^2 for undoped [24] WO_3 to 1.511 mA cm^2 . Electrochemical sensor properties of PANI/Cellulose/ WO_3 NS used in acetone gas detection at room temperature [25]. In the present work, the author envisaged that doping

Optimised Voltammetric Approaches for Clinical Sample Analysis

Gnanesh Rao¹, Raghu Ningegowda², B. P. Nandeshwarappa³, Kiran Kumar Mudnakudu-Nagaraju⁴, M. B Siddesh⁵ and Sandeep Chandrashekarappa^{6,7,*}

¹ Department of Biochemistry, Bangalore University, Bangalore, Karnataka, India

² Jyoti Nivas College Autonomous, Department of Studies in Chemistry, Bangalore-560095, India

³ Department of PG Studies and Research in Chemistry, Shivagangothri, Davangere University, Davangere, Karnataka - 577 007, India

⁴ Department of Biotechnology & Bioinformatics, Faculty of Life Sciences, JSS Academy of Higher Education and Research, Mysore 570015, Karnataka, India

⁵ Department of Chemistry, KLE'S S. K. Arts College and H. S. K. Science Institute, Hubballi, Karnataka 580031, India

⁶ Institute for Stem Cell Science and Regenerative Medicine, NCBS, TIFR, GKVK-Campus Bellary road, Bengaluru 560065, Karnataka, India

⁷ Department of Medicinal Chemistry, National Institute of Pharmaceutical Education and Research (NIPER) Raebareli, Lucknow (UP)-226002, India

Abstract: Extraordinary properties of nanomaterial lay a broad prospect for its application in various fields. Biosensors are a kind of special sensor which consists of biomolecule recognition element and transducer. Advances in biosensors with the use of micro/ nanomaterials are capable of detecting and analyzing living and chemical matter with high specificity, fastness, sensitivity, accuracy and low cost for the determination of proteins, hormone, enzyme, nucleic acid and other biological compounds in blood and urine samples. The basics of biosensors and optimized approaches for voltammetric clinical analysis are studied in this chapter. Exosomes are small extracellular vesicles (EV) involved in extracellular communication between cells, and are recognized as potential markers of human health and diseases. An extensive molecular characteristic comparison of the exosomal components of healthy and disordered cells or tissues reveals the differences.

- Electrochemical approaches for the analysis of clinical samples are developing at an incredible rate with advances in nanotubes and nanomaterials as biosensors.

* **Corresponding author Sandeep Chandrashekarappa:** Institute for Stem Cell Science and Regenerative Medicine, NCBS, TIFR, GKVK-Campus Bellary road, Bengaluru 560065, Karnataka, India And Department of Medicinal Chemistry, National Institute of Pharmaceutical Education and Research (NIPER) Raebareli, Lucknow (UP)-226002, India; E-mail: sandeep_m7@rediffmail.com, c.sandeep@niperraebareli.edu.in

- Exosomes play a crucial role in cell-to-cell communication in normal health and disease. They are potential biomarkers exploited for emerging non-invasive diagnosis.
- CNT sensors are capable of precise quantitative and qualitative detection of analytes.

Keywords: Affinity biosensor, Clinical analyte, CNT, CPE, Enzymatic biosensor, Exosome, Immunosensor, Voltammetric biosensor.

INTRODUCTION

The analysis of bodily fluids, especially urine, for the diagnosis of disease or disorder dates back to pre-3000 BC; writings and drawings serve as evidence. Chang Chung-Ching (AD 229), Charaka and Susruta (5th century) observed that individuals with sugar metabolism disorder presently termed as Diabetes mellitus are likely to be diagnosed by analyzing the urine of an individual for the presence of sugar. For this, dogs and ants served like sensors [1].

The chemical analysis of metabolite started with analyzing the urine for glucose and albumin in the 18th century. The knowledge of analysis has grown to an extent that the molecular characterization for diagnosis of a genetic disorder in a fetus is possible. The advances in sensors technology have resulted in the development of Point Of Care diagnosis, which is most convenient, faster and reliable [2 - 4].

The basics of a general biosensor are graphically represented in Fig. (1).

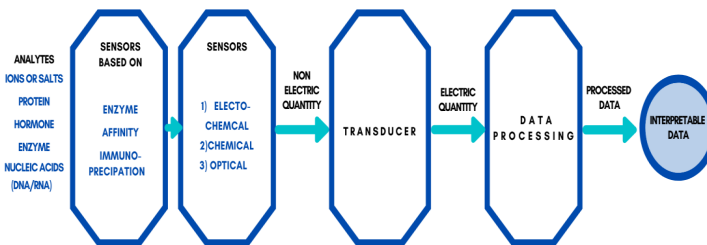

Fig. (1). General elements of a Biosensor.

CLINICAL ANALYTES

Cells are the product of millions of years of evolution; tissues are a step forward complex than cells with the capability of maintaining different chemical and physical conditions yet capable of performing a prefixed function.

The features of intracellular and intercellular signalling play a crucial role in homeostasis and disease. Cells communicate *via* a free or bound form of ions and biomolecules such as protein, hormone, enzyme, nucleic acid, *etc.*

Exosomes are 30-100nm vesicles that are released by most of the tissue systems in the body. The enclosed cargo of proteins, enzymes, and RNAs from the cell of origin renders exosomes the capability for intercellular signaling [5 - 10].

They are abundant in blood, which contributes to relay the function from proximal to target tissues. The ability to access exosomes from mostly any biological fluid offers a minimally invasive window for biochemical diagnosis [11 - 15].

Cell-to-cell communication is not only essential for repair and growth but also required for cell survival, cells failing to receive enough survival factor enter into the stage of apoptosis, possibly avoided by the use of many pharmaceutical drugs [16 - 25]. Signaling systems are initiated at the early stage of the differentiation of cells in the fertilized egg (Fig. 2) [26, 27].

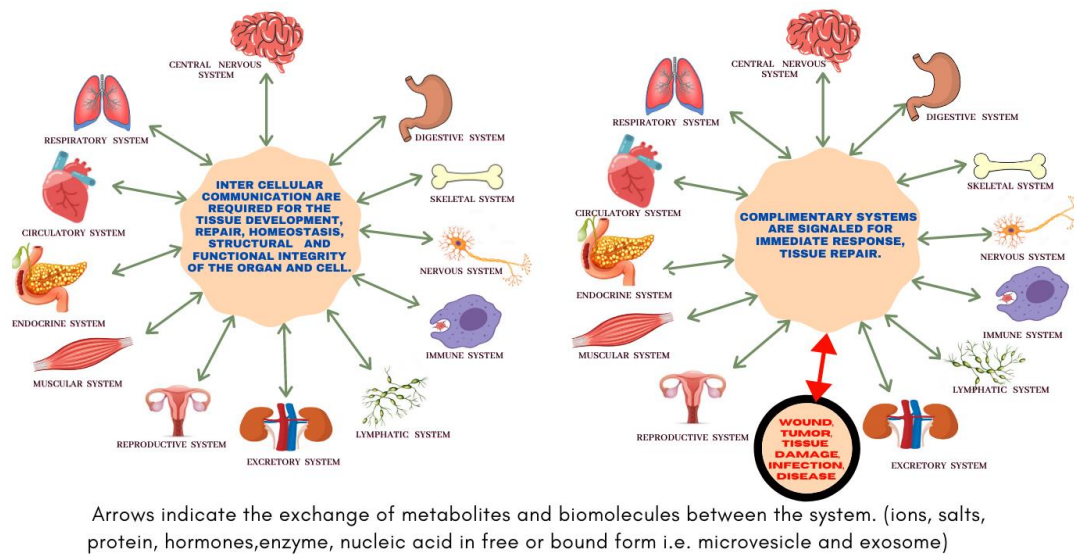

Fig. (2). Representative diagram of intercellular communication between organ systems.

Analysis of Clinical Analytes using Voltammetric Biosensor

Voltammetric biosensor is based on electrochemical techniques in which quantitative analysis of analyte is made by varying the potential and measuring the resulting current as an analyte reacts electrochemically with the surface of the working electrodes [28, 29]. Cyclic voltammetry (CV) and differential pulse voltammetry (DPV) are the most commonly applied techniques for the determination of redox potential and electrochemical reaction rates of analyte solutions (Fig. 3) [30, 31].

Recent Advances on Electrochemical Sensors for Detection and Analysis of Heavy Metals

Monima Sarma^{1,*}

¹ Department of Chemistry, KL Deemed to be University (KLEF), Greenfields, Vaddeswaram, Andhra Pradesh 522502, India

Abstract: Since the beginning of modern civilization, heavy metals have been used in various industrial, domestic, technological, medical applications, *etc.* Often, if not all the time, the uncontrolled release of sewage to the water resources and emission from the industrial plants in the environment raises alarms over their potential impacts on human health and the environment. These metallic elements, being potentially toxic, are known to cause multiple organ impairment, even at extremely low exposure limits. Thus, it is highly imperative to develop simple and sensitive methods for their detection. Electrochemical techniques are one of the most promising methods for heavy metal sensing because of their short analytical time, easy accessibility, and high sensitivity for *in-situ* measurements. In this chapter, we discuss heavy metals and their potential adverse effects on human health and the environment, strategies for the design of materials for sensing the heavy metals/ions and their mechanisms, and the recent developments of electrochemical sensors in heavy metal detection. The chapter puts more emphasis on materials than methods.

Keywords: Biochemical detection, Biomaterials, Electrochemistry, Electrochemical detection, Electrochemical sensing, Enzyme, Fuel cells, Heavy metal ions, Inorganic nanomaterials, Microorganism, Organic nanomaterials, Photocatalysis, Recognition, Redox reactions, Screen-printed electrochemical sensors, Self-powered electrochemical sensors, Sensors, Toxicity, Voltammetry, Wastewater analysis.

INTRODUCTION

What are electrochemical sensors? The word sensor originated from the Latin word *sentire*, meaning ‘to feel.’ Sensors have become progressively more important with the advancement of modern civilization. The invention of the Internet of Things (IoT) has taken the importance of sensors to an even greater level, and basically, human life these days is as dependent on man-made sensors

* Corresponding author Monima Sarma: Department of Chemistry, KL Deemed to be University (KLEF), Green fields, Vaddeswaram, Andhra Pradesh 522502, India; Email: monima.22@gmail.com

as it is on the biological ones to sustain life. Sensors are mechanical devices that respond to a physical or chemical perturbation such as light, temperature, magnetism, pressure, electric field, movement, pH, chemical reactions, *etc.* which is understood by a computer after a converter converts these analog responses into digital electrical impulses and an amplifier amplifies them. In nature, each sensor is different and operates by different target-specific mechanisms. Chemosensors are the type of sensors that analyze and provide information on the qualitative and quantitative chemical composition of their environment [1]. The basic operating principle of a chemosensor is recognition of the analyte by the receptor fragment prompting a chemical change, followed by generation of the output signal by the transducer, which is then read by the built-in computer. These chemical sensors have widespread importance whereby the key parameters of such sensors are selectivity, sensitivity, detection limit, response time, and lastly, the size of the device. Ideally, the sensor should have great selectivity and sensitivity, a faster response time, and acceptable packaging size [2]. Since the boom in microelectronics and microengineering, devices have been miniaturized without compromising selectivity and sensitivity. Alike the physical sensors, the chemical sensors also have target-specific operating principles where the sensing mechanism could be one of the various possibilities such as absorption or emission of light, electrochemical responses, absorption or release of heat, *etc.*

Of the various types of known chemical sensors, electrochemical sensors have gained popularity due to some obvious advantages, as we shall discuss in this chapter. All these sensors contain electrodes that act as the transducer. These sensors have far-reaching applications in modern life, such as (a) gas sensors to detect the level of carbon monoxide, (b) water analysis for heavy-metal pollutants, (c) automobile exhaust analysis, (d) environmental monitoring, (e) food and health monitoring, (f) medical diagnostics (for example, blood glucose monitoring) and so on [3]. Perhaps the most common type of electrochemical sensor is a typical pH meter where an electrode assembly (the glass electrode) selectively responds to the change in acidity or alkalinity of water causing a fluctuation of the cell potential which is converted into the pH scale by a built-in computer.

The electrical response and introduction to the electroanalytical techniques:

The electrochemical sensors work mainly based on the variation of one of these properties in the presence of an analyte: potential difference (potentiometry), current (amperometry and voltammetry), resistance (conductometry), and capacitance. The potentiometric method involves the interface between an electrode surface and a solution and is an example of the interface method. On the contrary, the conductance of the solution is directly measured using two electrodes, and this is a non-interface method [3]. A common electroanalytical

method is potentiometry which involves a change in electrode potential in the presence of the analyte according to the following Nernst equation:

$$E_{cell} = E_{cell}^0 - \frac{RT}{nF} \ln \frac{a_{ox}}{a_{red}} \approx E_{cell}^0 - \frac{RT}{nF} \ln \frac{[ox]}{[red]} \approx E_{cell}^0 - \frac{0.0591}{n} \log \frac{[ox]}{[red]}$$

where, E_{cell} is the cell potential (formal potential), E_{cell}^0 is the standard cell potential, R is the universal gas constant ($\sim 8.314 \text{ J mol}^{-1} \text{ K}^{-1}$), T is the temperature in Kelvin, n is the number of electrons involved, F is Faraday constant ($\sim 96485 \text{ C mol}^{-1}$), and those in bracket are the concentrations (more accurately, activity) of the oxidized and reduced species in solution, respectively. The concerned instrument is called a potentiostat which also uses a reference electrode, for example, saturated calomel electrode, silver-silver chloride electrode, *etc.* The electrode potential of the reference electrode is usually insensitive to the chemical composition of the solution and remains constant throughout the experiment. The traditional electrochemical cells are three-electrode assemblies and consist of a working electrode on the surface of which occur the redox reactions, the reference electrode, and a counter electrode (usually a platinum wire) to complete the electric circuit [4].

Besides potential difference, the current is another electrical response that is used as a sensory mechanism; the concerned technique is known as chronoamperometry which measures the current flowing through the working electrode as a function of time. The concentration of the redox-active species is then calculated by correlating with the current flow using the following Cottrell equation:

$$I_t = \frac{nFAc_o D_o^{1/2}}{\pi^{1/2} t^{1/2}} = bt^{1/2} I_i$$

where I_t is current at time t (s), n is the number of electrons, F is Faraday constant (96485 C mol^{-1}), A is the area of the electrode (cm^2), c_o is the concentration of the oxidized species (mol L^{-1}), D_o is the diffusion coefficient of the oxidized species ($\text{cm}^2 \text{ s}^{-1}$) [5]. This method allows processes to be studied in which the current is directly measured as a function of a constant potential applied to the electrochemical system.

The most used electroanalytical technique is based on voltammetry, which measures the flow of current (I) between two electrodes as the potential difference (E) between them is varied [6]. The two popular voltammetry-based techniques

CHAPTER 8

Electrochemical, Sensing and Environmental Assessments of $\text{CuFe}_2\text{O}_4/\text{ZnO}$ Nanocomposites Synthesized via *Azadirachta Indica* Plant Extract

B. S. Surendra^{1,*}, N. Raghavendra¹, H. P. Nagaswarupa^{2,*}, T. R. Shashi Shekhar³ and S. C. Prashantha¹

¹ Department of Science, East West Institute of Technology, Bengaluru 560 091, Karnataka, India

² Department of Studies in Chemistry, Shivagangothri, Davangere University, Davangere - 577 007, Karnataka, India

³ Department of Civil, East West Institute of Technology, Bengaluru 560 091, Karnataka, India

Abstract: The $\text{CuFe}_2\text{O}_4/\text{ZnO}$ nanocomposite (CZO NCs) has been successfully synthesized by a facile one-pot green assisted approach using *Azadirachta indica* extract. These synthesized nanocomposites were characterized by different techniques; Powder X-ray diffractometer (PXRD) confirms the formation of nanocrystalline composite material with crystallite size in the range 15-30 nm. The surface morphology of prepared nanocomposite materials was changed due to the plant extraction action as reducing and capping agent studied by Scanning electron microscope (SEM), which shows porous and spongy like structure. The photocatalytic performance of CZO NCs was examined for their potential role in the photodegradation of Methylene Blue (MB) dye under UV light. The result shows that the 1:2 molar CZO NCs is suitable for excellent photocatalytic degradation performance of MB dye (98%). Electrochemical analysis of prepared material was conducted with graphite electrode paste in 0.1 M KCl electrolyte, which showed excellent performance in redox potential measured by Cyclic Voltammetry and extended their sensor activities towards chemical and bio-chemicals (Paracetamol and Glucose). These studies open a new platform to utilize a simple approach for the preparation of multifunctional CZO NCs for their potential applications in wastewater treatment and electrochemical studies.

Keywords: $\text{CuFe}_2\text{O}_4/\text{ZnO}$, Cyclic Voltammetry, Green combustion, Photocatalysis, Sensor, Wastewater treatment.

* Corresponding authors B.S. Surendra and H. P. Nagaswarupa: Department of Science, East West Institute of Technology, Bengaluru 560 091, Karnataka, India And Department of Studies in Chemistry, Shivagangothri, Davangere University, Davangere - 577 007, Karnataka, India; E-mail: surendramysore2010@gmail.com, nswarupa@davangereuniversity.ac.in,

J.G. Manjunatha (Ed.)

All rights reserved-© 2022 Bentham Science Publishers

INTRODUCTION

Nowadays, wastewater treatment practices have gained more priority in the world by the effect gradually increasing contamination of water from various sources like industries, laboratories, paper and pulp production, *etc.* causes a serious adverse effect to the environmental issues [1 - 5]. The wide utilization of synthetic dye products such as garments, leather trimmings, furniture equipment, chemical laboratories, *etc.* excludes approximately 10-12% of these dyes and departs into the surroundings. Therefore the efficient degradation of such toxic chemicals is a great task for water treatment in different fields of science and technologies. The final degraded products should be eco-friendly and their experimental practices must be sustainable are the solution things that are anticipated [6]. Generally, dyes are the major organic pollutants present in wastewaters, creating severe problems and thus, lead to developing effective methods for wastewater treatment [7]. Nanomaterials are the modern field of science which plays a vital role in all aspects of human activity such as electronic devices, telecommunication equipment, magnetic fluids, drug delivery, sensors, *etc.* with low cost and environmentally friendly approaches. Presently, the semiconductor nanomaterials have been employed as Photocatalyst, which can be used to degrade the pollutants as an ecological approach [8 - 11]. The heterogeneous catalysis process is extensively employed for the bleaching of such dye pollutants [12].

The ferrite nanomaterials are a common type of spinel tetrahedral and octahedral crystalline structures, which has attracted great attention due to their extensive technological applications and key subject in environmental contamination remediation *via* photocatalysis examination [13 - 15]. The copper based ferrites and their composites are recognized as semiconductor photocatalysts for efficient degradation of toxic chemicals through photocatalysis [16, 17]. The exposure of semiconductor materials to light of energy not less than electrons and holes generated from the band gap. In the conduction band, oxygen molecules accept the electrons and transforming into superoxide radical ion. Hydroxyl radicals generated from the oxidation of adsorbed water molecules on the surface of semiconductor in the valence band, which converts the organic pollutants to carbon dioxide and water [18, 19].

Recently, few works confirmed the functionality of green preparation of nanoparticles/nanocomposites using various plant extracts for domestic/industrial waste-water treatment [20]. The non-edible biomass resources (Neem (*Azadirachtaindica*), Jatropha, Pongamia, *etc.*) are the most abundant and alternative source of fossil diesel, offers several benefits for the environmental and economical needs. Various synthesis methods are applied to prepare nano metal oxides [21, 22] and among those, solution combustion approach is a

potential, economical and versatile methodology. This method involves a self-sustained reaction in homogeneous mixture of reactant oxidizers (e.g., metal nitrates) and green fuels (Neem (*Azadirachtaindica*) extract). Thus, this process has more assistance due to the advantage of ecological friendliness, easy for synthesis with cost effective, energy efficient approach *etc* [23 - 28]. CZO NCs have been preferred for this research work due to its activity towards anodic–cathodic potential properties. Also, the important movement has been achieved for the prepared nanocomposite in the sensor measurements. Therefore, the sensor activities of prepared material monitoring chemical and biochemical sensing applications are of great importance for sustaining human health and also in different detection practices [29 - 35]. As a result, CV analysis was carried out for CZO NCs to illustrate the modified graphite-composite electrode paste and extended their sensor activities towards chemical and biochemical such as Paracetamol and Glucose, respectively. With such outcomes, the present research work reported that the excellent performance of CZO NCs towards UV light induced photocatalyst for degradation of MB dye. The composition of nanocomposites has been synthesized methodically by varying the ratios of both the CuFe₂O₄ and ZnO oxides.

EXPERIMENT

Synthesis of CuFe₂O₄ nanoparticles and ZnO oxide

CuFe₂O₄ nanomaterials were synthesized by green combustion method using Cu(NO₃)₂·3H₂O and Fe(NO₃)₃·9H₂O as oxidizers. The stoichiometric ratios of oxidizer and fuel were taken in silica crucible with a small amount of water and subjected to stirring to attain homogeneity. Further, this homogeneous mixture was subjected to combustion in a muffle furnace at 550±10 °C.

Similarly, the same procedure was adopted for the preparation of ZnO nanoparticles mentioned above; instead of Cu(NO₃)₂·3H₂O and Fe(NO₃)₃·9H₂O, Zn(NO₃)₂ was used.

Synthesis of CuFe₂O₄-ZnO Nanocomposite

The CZO NCs photocatalysts were synthesized from mixing up of Cu(NO₃)₂·3H₂O, Fe(NO₃)₃·9H₂O and Zn(NO₃)₂ (NICE chemical (P)Ltd.) with various ratios (1:1, 1:2 & 2:1) by green combustion method. [Cu(NO₃)₂·3H₂O, NICE chemical (P)Ltd.; Fe(NO₃)₃·9H₂O, NICE chemical (P)Ltd.]. Analytical grade was used without further purification. The specific amounts of copper and ferric nitrates in stoichiometric ratios were used as initial precursors and *Azadirachtaindica* extract was used as a green fuel. Finally, the product was

Advanced Sensor Materials for the Simultaneous Voltammetric Determination of Antihypertensive Drugs: An Overview

Carlos Alberto Rossi Salamanca-Neto¹, Bruna Coldibeli¹, Erison Pereira de Abreu², Gabriel Junquetti Mattos¹, Gabriel Rainer Pontes Manrique¹, Jessica Scremin¹, Natalia Sayuri Matunaga Campos¹, Débora Nobile Clausen^{1,2} and Elen Romão Sartori^{1,*}

¹ *Laboratório de Eletroanalítica e Sensores, Departamento de Química, Universidade Estadual de Londrina (UEL), Rodovia Celso Garcia Cid, PR 445 Km 380, Londrina – PR, C.P. 10.011, 86057-970, Brazil*

² *Departamento de Biomedicina, Centro Universitário Cesumar (UniCesumar), Avenida Santa Mônica, 450, Londrina – PR, 86027-610, Brazil*

Abstract: Antihypertensives are one of the most consumed drugs worldwide. To reduce pill burden, more than one class of antihypertensive drugs can be found in the same tablet in a fixed-dose combination. In this chapter, an overview of about 35 papers reporting on the advanced sensor materials for the voltammetric simultaneous determination of antihypertensive drugs will be presented. Special attention is given to the strategies the authors used for enabling simultaneous determination. Several types of carbon-based electrodes were considered as a voltammetric sensor platform for the development of simultaneous determination procedures. The samples analyzed were fixed-dose tablets, preferentially, but human fluids and water samples were also analyzed. Voltammetric methods used for the simultaneous determination of antihypertensive drugs revealed very sensitive approaches reaching limits of detection in the micro- and nanomolar levels with analysis lasting less than one minute and consuming very low or even no organic solvents.

Keywords: Antihypertensives, Carbon-based electrodes, Electroanalytical methods, Modified electrode, Simultaneous determination.

* **Corresponding authors Carlos A.R. Salamanca-Neto and Elen Romão Sartori:** Laboratório de Eletroanalítica e Sensores, Departamento de Química, Universidade Estadual de Londrina (UEL), Rodovia Celso Garcia Cid, PR 445 Km 380, Londrina – PR, C.P. 10.011, 86057-970, Brazil; Tel: +55 43 3371-4366; Fax: +55 43 3371-4286; E-mail: carlos.salamanca@uel.br and elensartori@uel.br

INTRODUCTION

Antihypertensive drugs are widely used by the population to reduce arterial hypertension on a daily and continuous basis [1]. Pharmaceutical formulations containing these drugs must undergo strict quality control in the pharmaceutical industry for human consumption.

Electroanalytical methods based on voltammetric techniques and advanced sensor materials have been considered for this purpose. The use of these techniques in the development of new analytical protocols for the simultaneous determination of antihypertensive drugs has increased in recent years [2 - 5]. The analytical advantages of the various voltammetric methods include high precision, accuracy, simple sample preparation, short analysis time, and minimal or no use of organic solvents, which makes them low cost and environmentally friendly procedures for large scale applications [2 - 7]. Additionally, several types of carbon-based materials, nanostructured or not, have been considered as a sensing platform for the simultaneous determination of different chemical species.

Considering these aspects, in this review, we have comprehensively summarized papers reporting the use of advanced sensors materials for the simultaneous determination of antihypertensives. The methods were categorized according to the type of material employed as the sensing element, and tables present the analytical characteristics towards the simultaneous determination of antihypertensives.

THE CURRENT APPLICATION OF ANTIHYPERTENSIVE AGENTS ON CARDIOVASCULAR EVENTS

Cardiovascular diseases are considered the major cause of death in the world, and hypertension is an important risk condition for the occurrence of cardiovascular events, as stroke, coronary disease, peripheral disease, cardiac insufficiency, and chronic kidney disease [8, 9]. Hypertension can be assigned to several causes, including behavior, genetic, metabolic, and unknown factors [10]. Besides the recommendation of a healthy lifestyle as the first strategy to reduce blood pressure, pharmacological intervention plays an essential role in the effectiveness of hypertension treatment. Antihypertensive agents consist of a diverse group of drugs that are classified according to their mechanisms and locals of action [1].

Blood pressure control with antihypertensives can be achieved by monotherapy of one drug or combined therapy with simultaneous administration of two or more drugs. Despite the divergence about the topic, the combined-therapy approach has become increasingly popular in the medical field, supported by the many favour-

able features. However, a suitable antihypertensive treatment must be prescribed, considering each patient individually [11, 12].

In combined therapy, low dosages result in reduced incidence of drug-related side effects, while the different drug properties act synergistically on different antihypertensive mechanisms for a more effective blood pressure lowering. Furthermore, this approach can be managed with separate products or a fixed-dosage combination product, which consists of a more appreciated way because it improves patient compliance with the treatment [11 - 13].

The antihypertensive classes available for medical practice nowadays are diuretics, β -blockers, angiotensin-converting enzyme (ACE) inhibitors, calcium antagonists, and angiotensin receptor blockers.

Diuretics have been an important class of antihypertensive agents since the 1950s. These drugs act on the renal system, increasing Na^+ and H_2O excretion, and are effective for reducing blood pressure in monotherapy or enhancing the efficiency of other antihypertensives when used as an association. They are subclassified in thiazide diuretics (*e.g.* hydrochlorothiazide), loop-diuretic (*e.g.* furosemide), and potassium-sparing diuretics (*e.g.* amiloride and triamterene). Thiazide-types are the primary choice in pharmacological treatment due to their efficacy, but differently from the other diuretics, potassium-sparing ones are prescribed in association with another diuretic to attenuate the excessive excretion of potassium (kaliuresis) [1, 8].

The β -blocker drugs were introduced in clinical medicine as antihypertensive agents in the 1960s. This group is divided into three generations, according to its β -adrenergic receptor selectivity and vasodilatory properties. The first-generation or non-selective β -blockers (*e.g.*, propranolol and pindolol) have similar affinities for β_1 and β_2 -adrenergic receptors. The second-generation or selective β -blockers (*e.g.*, metoprolol, bisoprolol, and atenolol) present a higher affinity for β_1 -receptors. Consequently, they reduce the incidence of adverse effects from the blockage of β_2 -receptors. The third generation (*e.g.*, carvedilol and nebivolol) are vasodilators [14, 15].

The renin-angiotensin-aldosterone system (RAAS) expresses an important relationship with the homeostatic control of arterial pressure; therefore, hypertension can be related to dysregulation in this system. In this sense, RAAS blockers have been used as antihypertensive agents and include angiotensin-converting enzyme (ACE) inhibitors (*e.g.*, captopril, ramipril, enalapril, and lisinopril) and angiotensin receptor blockers (*e.g.*, valsartan, losartan, and telmisartan) [8, 16].

Voltammetric Applications in Anti-inflammatory Drug Detection

B. P. Sanjay¹, D. N. Varun¹, S. Sandeep¹, C. S. Karthik¹, A. S. Santhosh², P. Mallu¹ and Nagaraja Sreeharsha^{3,4}

¹ Department of Chemistry, JSS Science and Technology University, Mysuru- 570006, Karnataka, India

² Department of Chemistry (UG), NMKRV College for Women, Jayanagar, Bengaluru – 560011, India

³ Department of Pharmaceutical Sciences, College of Clinical Pharmacy, King Faisal University, Al- Ahsa-31982, Saudi Arabia

⁴ Department of Pharmaceutics, Vidya Siri College of Pharmacy, Off Sarjapura Road, Bengaluru - 560035, Karnataka, India

Abstract: The past few years have seen substantial development in electrochemical sensors. The fundamental challenge in the construction of reliable analytical techniques for the quantification of anti-inflammatory drugs has been conveniently overcome by electrochemical methods. Voltammetric sensors have applications in biological, environmental, and chemical structures. Owing to their high sensitivity, selectivity, ease of preparation, and fast reaction, voltammetric sensors for detecting specific biomolecules have received significant attention in recent years. Polarography, cyclic voltammetry (CV), Differential Pulse Voltammetry (DPV), and Squarewave Voltammetry (SWV) are examples of electrochemical techniques that are classified. Non-steroidal anti-inflammatory drugs (NSAIDs) such as 4-amino antipyrine (4-AAP), Indomethacin (IND), and Diclofenac (DCF) are widely used in the treatment of inflammatory conditions such as musculoskeletal disorders, dental pain, menstrual pain, postoperative pain, and migraines. This chapter discusses the details and usages of the different voltammetric methods for the determination of NSAIDs.

Keywords: Anti-inflammatory drugs, Classifications of voltammetric techniques, Diclofenac, Indomethacin, Voltammetric applications, 4-Aminoantipyrine.

INTRODUCTION

The advancement of the human race can be witnessed with improved technologies, new inventions, and new paradigms being developed every day

* Corresponding Author S. Sandeep: Department of Chemistry, SJCE, JSS Science and Technology University, Mysuru, India; E-mail: sandeeps@jssstuniv.in

using cutting-edge technology [1]. However, in contrast, there is an increase in the number of illicit drugs and trafficking uses, which causes problems for society, health, criminality, and the environment [2]. In addition, the number of unpredictable health issues in humans compels researchers worldwide to investigate accurate analytical techniques for drug detection in seized street samples, biological fluids, and wastewater [3]. Drug detection plays a vital role in the modern pharmaceutical industries involving tedious and cumbersome processes like formulation and stability studies, quality control (QC), and toxicology and pharmacological testing in animals and man. In clinical industries, drug detection is carried out using biological samples like blood, urine and saliva in support of clinical trials, *i.e.*, bioavailability and pharmacokinetic studies, and in the monitoring of therapeutic drugs and drug abuse [4]. These investigations require simple, novel, rapid, and reliable analytical methods to measure drugs in complex media such as formulation and biofluids. In this background, electrochemistry takes center stage by fulfilling all the criteria for an efficient analytical tool [5]. In particular, voltammetric methods for the determination of drugs have received enormous attention in recent years. This is due to the sensitivity and selectivity they provide on qualitative and quantitative aspects of the electroactive analyte under study [6]. This chapter, will explore the commonly used voltammetric techniques, electrodes utilized, modification procedures for the electrodes, solvents, and supporting electrolytes highlighting their electrochemical performances and limitations. Finally, we devote special attention to outlining the future trends of the electrochemical methods for drug analysis [7]. Voltammetry is part of electrochemistry, which was known after the discovery of polarography in 1922 by the Czech chemist Yaroslav Heyrovsky, for which he received the Nobel Prize in 1959 [8]. The techniques utilized in early voltammetry encountered several challenges, making them less applicable for routine analysis. However, around the 1960s and 1970s, considerable advances were made in all the fields of voltammetry, which expanded its application in different areas. Voltammetry gives data about oxidation, adsorption, and thermodynamic properties of solvated species [9].

CLASSIFICATION OF VOLTAMMETRY TECHNIQUES

Polarography

The concept of pulse polarography was introduced by the English chemist G.C. Barker (Fig. 1 A-C). Initially, the theory relied on the results of Barker's work on square wave polarography [6]. Barker and colleagues explored the principle of pulse polarography in various correspondences, adapted a portion of the hypothetical aspects of square wave polarography to pulse polarographic methods, and presented the overall instrumentation [10]. Polarography is also part

of the electrochemistry procedure, which examines liquid solutions containing oxidizing or reducing substances. It is one of the most broadly utilized voltammetric methods. In this procedure, the estimations are directed based on diffusion mass transport [11]. It is accepted that mercury terminals are the most basic anodes with smooth surfaces and a high cathodic potential window, which is utilized to determine the reducible substances [12]. The ongoing investigation demonstrated noteworthy points of interest over the recently revealed strategies, including high affectability and brief time frame devouring. Moreover, they do not need a pretreatment of samples before analysis.

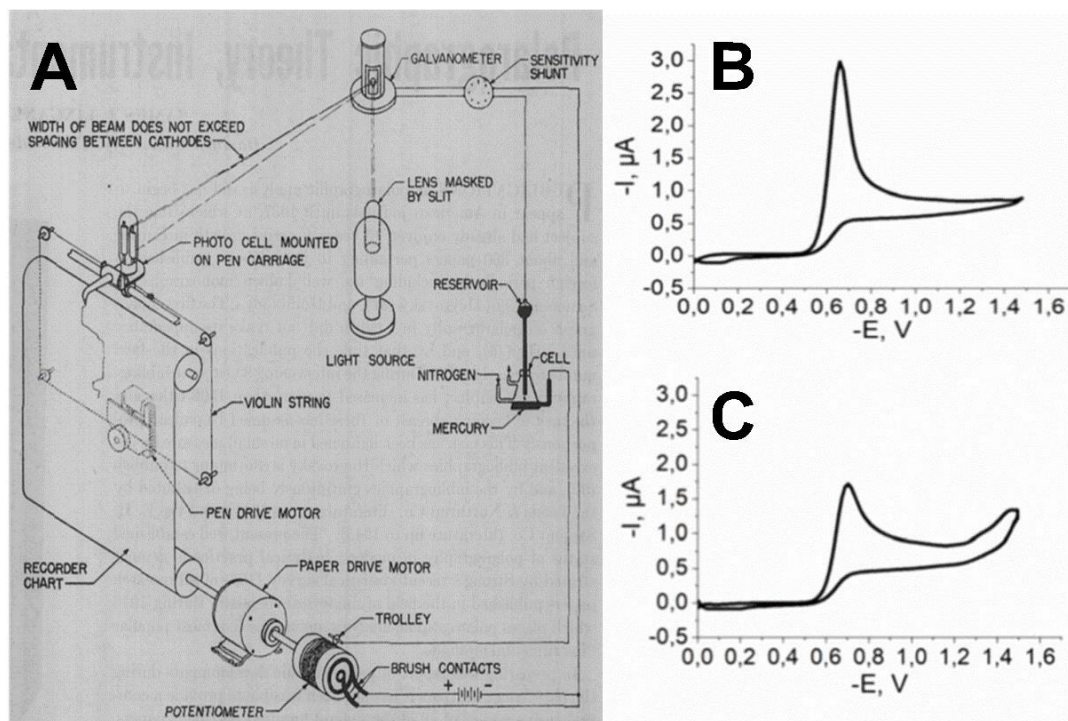

Fig. (1). (A) Schematic Diagram of Lykken-Pompeo-Weaver Polarograph. (B) and (C) graphs of Polarograms [13].

Cyclic Voltammetry

Cyclic voltammetry (CV) is one of the most efficient electroanalytical methods for the investigating of electroactive species. The use of CV is versatile, with applications in electrochemistry, organic chemistry, materials science, natural science, *etc.* CV is efficacious because of its ability to observe redox activity quickly across a large possible range. The resulting voltammogram is similar to a normal range because it propagates information as part of an energy channel [14].

Voltammetric Applications in Drug Detection: Mini Review

G. Krishnaswamy^{1,*}, G. Shivaraja¹, S. Sreenivasa^{2,3,*} and Aruna Kumar D. B.¹

¹ Department of Studies and Research in Organic Chemistry, Tumkur University, Tumakuru-572 103, Karnataka, India

² Department of Studies and Research in Chemistry, University College of Science, Tumkur University, Tumakuru-572 103, Karnataka, India

³ Deputy Adviser, National Assessment and Accreditation Council, Bengaluru-560 072, Karnataka, India

Abstract: The application of electroanalytical techniques plays a very important role in the field of medicinal and pharmaceutical research. These techniques have been routinely used by analytical, inorganic, organic physical as well as biological chemists. In recent years the various voltammetric methods such as Differential pulse voltammetry, Cyclic voltammetry, Linear sweep voltammetry, Square wave voltammetry, Stripping voltammetry *etc* have gained enormous attention for the determination of different classes of drugs. Electroanalytical techniques gain supreme importance over other techniques in terms of the quantization of trace and ultra-trace components of biological fluids as well as pharmaceutical substances. Therefore, these techniques are alternative in detection and analysis due to their sensitivity, reproducibility and selectivity in terms of qualitative as well as quantitative aspects of the analyte under investigation. The present review focuses on the application of various voltammetric techniques for the analysis of analgesics, antibiotics, anthelmintic, anti-tubercular and anticancer drugs covering the period from 2015 to present.

Keywords: Analgesics, Anthelmintics, Antibiotic, Anticancer, Antitubercular, Cyclic voltammetry, Drug detection, Electroanalytical techniques.

INTRODUCTION

Voltammetry technique was developed in 1920s by Jaroslav Heyrovsky a Czechoslovakian chemist and in that year, an important electro analytical techni-

* Corresponding authors G. Krishnaswamy and S. Sreenivasa: Department of Studies and Research in Organic Chemistry, Tumkur University, Tumakuru-572 103, Karnataka, India and Deputy Adviser, National Assessment and Accreditation Council, Bengaluru-560 072, Karnataka, India; E-mail: drkrishna23org@gmail.com, drsreenivasa@yahoo.co.in

que for the analysis of different pharmaceutical substances was developed [1]. Generally, Voltammetry technique is widely used because it provides both qualitative as well as quantitative information of electroactive sample based on the applied electric potential and current, respectively. Simple modified electrodes have been used as sensors for the electrochemical characterization of various bioactive molecules like riboflavin [2 - 5], Tyrosine [6], Dopamine [7], Uric acid, Ascorbic acid [8 - 10], Estriol [11, 12], Isatin [13], Phloroglucinol [14, 15], L-tryptophan [16], Vanillin [17] and also dyes such as Alizarin Red-S [18] and Indigotine [19].

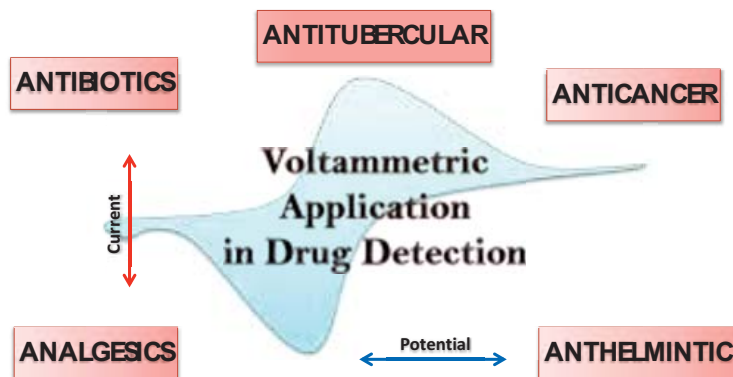

Voltammetry Techniques such as:

- Cyclic Voltammetry (CV) and Linear Sweep Voltammetry (LSV) were used to study the kinetics of electrochemical reactions, reversible and irreversible reactions as well as determination of formal redox potentials of the analyte since these techniques provide linear continuous changing potential with time.
- In Differential Pulse Voltammetry (DPV), the cell current is measured as a function of time and potential between the indicator and reference electrodes. DPV improves detection limits and is highly sensitive for the quantitative determination of electroactive drug compounds.
- Square Wave Voltammetry (SWV) is a large amplitude differential technique in which a waveform composed of symmetrical square wave compared with DPV. It requires a small amount of electroactive species and a very fast response is obtained due to an effective high scan rate.
- Stripping Voltammetry (SV) can be called as a sub division of voltammetric techniques and classified into four types namely, anodic (ASV), Cathodic (CSV), Adsorptive (AdSV), and Potentiometric Stripping Voltammetry (PSV). This technique uses a step of preconcentration to accumulate the analytes on the electrode surfaces for dilute samples, followed by the measurement of electroch-

emical response leading to trace level determination of pharmaceutical compounds.

Inspired by the important applications of the various voltammetric techniques. Here in the following section, we present the electrochemical characterization studies of antibiotics, analgesics, anthelmintic, anti-tuberculosis and anti-cancer drugs highlighting mainly electrode material, techniques employed and detection limit.

ELECTROCHEMICAL CHARACTERIZATION OF ANTIBIOTICS

Penicillin is a group of antibiotics, which are used to treat different bacterial infections in humans, livestock, and poultry.

Zhao *et al.* [20] in 2016 reported an electrochemical APTA sensor for highly sensitive detection of penicillin at GNS nanocomposite (GR-Fe₃O₄ NPs) and a poly (3, 4-ethylenedioxy-thiophene)-AuNP composite (PEDOT-AuNPs) using modified glassy carbon electrode (GCE) employing differential pulse voltammetry (DPV) method with a limit of detection (LOD) of 1.70×10⁻¹⁶ M. Li and co-workers [21] in 2015 reported an immuno sensor for detection of penicillin based on supported bilayer lipid membrane (s-BLM)-AuNP modified glassy carbon electrode (Au-sBLM/GCE) employing Cyclic Voltammetry (CV) with a limit of detection (LOD) of 8.07×10⁻¹⁶ M. Salihu *et al.* [22] in 2019 reported Nickel nanoparticle (Ni-NP) modified screen-printed carbon electrode (SPCE) for the electrochemical detection of penicillin in bovine milk samples with a limit of detection (LOD) of 0.00031 μM. Wizral *et al.* [23] in 2019 reported boron doped diamond electrode for determination of penicillin G in aquatic samples using differential pulse voltammetric (DPV) method with detection limit of (LOD) 0.23 μM. The limit of detection for penicillin G detection using various voltammetric methods were compared in Table 1.

Table 1. Comparison of different electrochemical sensors for voltammetric determination of penicillin G.

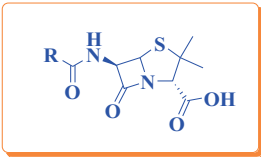
Chemical Structure			
			
Electrode	Method of Analysis	LOD (M)	Refs.
GR-Fe ₃ O ₄ NPs/ PEDOT-AuNPs/ GCE	DPV	1.70×10 ⁻¹⁶	[20]

Voltammetric Application in Detection of Anticancer Drug

Shankar Ashok Itagi¹, M. H. Chethana¹, P. Manikanta¹, S. Sandeep¹, C. S. Karthik¹, A. S. Santhosh², K. S. Nithin³, Kumara Swamy N. K.¹ and P. Mallu¹

¹ Department of Chemistry, Sri Jayachamarajendra College of Engineering, JSS Science and Technology University, Mysuru, Karnataka 570006, India

² Department of Chemistry, NMKRV College for Womens, Jayanagar, Bengaluru

³ Department of Chemistry, The National Institute of Engineering, Mysuru, Karnataka 570008, India

Abstract: From the past few years the development of electrochemical sensor has gained more attention due to the fact that these methods have high sensitivity, less expensive and easy to handle when compared to other conventional methods. Cancer is one among the serious disease faced by the human race in the current era. Presently, It is treated with various treatments like chemotherapy, surgery and radiotherapy. Since the impressive growth of these prime treatments, ample of anticancer drugs have been developed. Alongside in recent years, the synthesis of nanomaterials and their application in medicinal (biomedical) field has gained quite a focus in the research field. Due to smaller size, improved solubility, surface tailor ability, electrocatalytic activity, sensible detection and multifunctionality the nanomaterials are found to possess greater applications in the growing field of pharmaceutical research. The present chapter gives the reports on the electrochemical detection of various anticancer drugs like Methotrexate (MTX), 5-Flourouracil, Doxorubicin and Etoposide.

Keywords : Anticancer drugs , Doxorubicin , Etoposide , Methotrexate , Nano materials , Voltammetric methods , 5-Flourouracil .

INTRODUCTION

In the present era, cancer is termed as a major global issue causing many annual deaths. The impact of this issue has led to the development of variety of expensive drugs and treatments [1]. One such drug is methotrexate which is a derivative of folic acid antagonists, that finds application as an anticancer and anti-inflammatory agent [2].

* Corresponding author S. Sandeep: Department of Chemistry, SJCE, JSS Science and Technology University, Mysuru, India; E-mail: sandeeps@jssstuniv.in

In the last few decades, chemotherapy is employed as one among the best main major medical advancements in cancer care [3]. However, the medications employed for this practice possesses a limited therapeutic index and the response obtained are often soothing and unpredictable [4]. Though biomacromolecules are the components which are pointed by these approaches, the drawback found by these are failure in discriminating among swiftly splitting non-malignant and tumour cells [5]. In recent years, targeted therapy has been aimed toward tumour-specific targets and signalling pathways, and therefore has relatively more limited nonspecific mechanisms [6]. A number of studies have shown a key role for epigenetic pathways in the development of cancer. Genetic alteration alone is incapable of explaining carcinogenesis; thus, it includes epigenetic processes (DNA methylation, histone modifications and non-coding RNA deregulation) [7]. The chromatin decondensation which is asserted by condensins and interactions between histones caused by H3 and H4 histones lysine deacetylation which are part of the Histone decondensation [8].

The advancement of chemotherapy has led to the maximal cure of many cancer cells by the utility of numerous anti-cancer drugs [9]. However, this progress has attributed to the further establishment of innovative treatment techniques *i.e.*, surgery and radiation therapy. The keen draw back of the chemotherapeutic treatment is their cause of harmfulness on normal tissues of the body [10]. The bone marrow, gastrointestinal tract, hair follicle *etc* are the vital points that are majorly affected by the acute toxicities of chemotherapeutic treatment [11].

The common toxicities encountered are haematological, gastrointestinal, skin and hair follicle toxicity, nervous system toxicity, local toxicity, metabolic disturbances, hepatic toxicity, urinary tract toxicity, cardiac toxicity, pulmonary toxicity, gonadal toxicity, *etc* [12].

The cancer victims are frequently examined with various drug therapies which not only include chemotherapeutic agents but also includes non-chemotherapeutic drugs. The care should be taken in such a way that, the treatment should not encourage the growth of the tumour or cause toxicity to other tissues [13].

The anticancer drugs that can be detected using various methods are as follows:

1. Methotrexate (MTX)
2. 5-Flourouracil
3. Doxorubicin
4. Etoposide

METHOTREXATE

MTX differs structurally from folic acid by two sites:

- hydroxyl group replaces amino group in one site.
- methyl group replaces an amino at another [14].

MTX (amethopterin, 2,4-diamine-N10-methylpteroyl-glutamic acid) being a folic acid counterpart varies from that by an amino group being replaced by the hydroxyl group at the C4 region on the pyrimidine ring (Fig. 1). It finds its application in treatment of various illness. However, the usage of this drugs results in effects like marrow suppression, gastro-intestinal lesions, renal insufficiency, hepatic failure, hypoalbuminemia, and pancytopenia [15]. It is therefore, very important to establish a responsive and versatile method for the assessment of MTX [16]. The structure of MTX is shown in below Fig. (1).

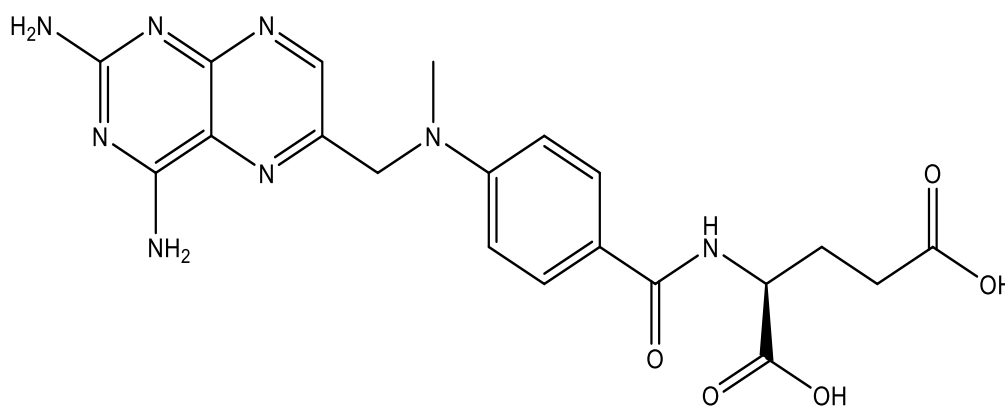

Fig. (1). The structure of Methotrexate.

Deng, Z et al. synthesised stearyltrimethylammoniumbromide (STAB)/novel acetylene black (AB). The modified sensor showed lower detection limit of 3.07 nM with linear range of 0.005 μM to 7.0 μM which showed application in determination of MTX [17]. *Deng, Z et al.* fabricated acetylene black (AB) on glassy carbon electrode which resulted in the development of novel sensor. The so designed sensor showed linear relationship within range of .005 μM to 3.0 μM with detection limit of 3.81 nM for MTX [18]. *Chen, J et al.* reported glassy carbon electrode (GCE) modified with graphene oxide (GO) for sensitive detection of MTX. This showed higher range of 5.5×10^{-8} to 2.2×10^{-6} mol L⁻¹ with a lower limit of detection 7.6×10^{-9} mol L⁻¹ [19]. *Ensafi, et al.* constructed an electrochemical sensor by modifying glassy carbon electrode with CoFe₂O₄/

Voltammetric Studies of Dyes and their Role as Carbon Electrode Modifiers

Shefali Sharma¹, Anup Pandith², Shankramma Kalikeri³, Nagaraja Sreeharsha^{4,5} and Gururaj Kudur Jayaprakash^{1,*}

¹ School of Advanced School of Chemical Science, Shoolini University, Bajhol, Himachal Pradesh 173229, India

² Department of Chemistry, School of Natural Sciences, Kyung Hee University, Seoul, South Korea

³ Division of Nanoscience and Technology, Department of Water and Health (Faculty of Life Sciences) JSS Academy of Higher Education & Research (Deemed to be University), Mysuru, Karnataka 570004, India

⁴ Department of Pharmaceutical Sciences, College of Clinical Pharmacy, King Faisal University, Al-Ahsa-31982, Saudi Arabia

⁵ Department of Pharmaceutics, Vidya Siri College of Pharmacy, Off Sarjapura Road, Bengaluru – 560035, Karnataka, India

Abstract: Synthetic dyes are very commonly seen in commercial products nowadays. Synthetic dyes are commonly used to give a variety of colors and shades in several commercial products. The occurrence of synthetic dyes in water after certain levels can significantly affect living beings by causing toxicity and mutagenicity. Electroanalytical methods can detect these dyes with high sensitivity and selectivity. It is also interesting to note that, commercial dyes like calmagite, rhodamine, Congo red, and many more have shown significant applications as electrode modifiers. In the current chapter, we are going to discuss the use of electrochemical methods to sense commercial dyes and applications of dye-modified carbon paste electrodes in the voltammetric analysis.

Keywords: Carbon paste, Dyes, Real samples, Sensors, Voltammetry.

INTRODUCTION

In the past century, synthetic dyes have become more common in industrialization and they have been extensively used as colors and shades in many commercial products like textile, foods, paper, and cosmetics [1-5]. The organic dyes are typically complex aromatic compounds with substantial structural diversity.

* Corresponding author Gururaj Kudur Jayaprakash: School of Advanced School of Chemical Science, Shoolini University, Bajhol, Himachal Pradesh 173229, India; rajguru97@gmail.com

Most organic compounds, dyes possess color because they absorb light in the visible spectrum (400-700 nm); have at least one chromophore (color-bearing group); have a conjugated system *i.e.*, a structure with alternating double and single bond and exhibit resonance of electrons, which is a stabilizing force in organic compounds. When any one of these features is lacking from the molecular structure the color is lost. In addition to chromophores, most dyes also contain groups known as auxochromes (color helpers), examples of which are carboxylic acid, sulfonic acid, amino, and hydroxyl groups. Increasing the number of electron-attracting groups conjugated with the electron-donor has a bathochromic effect.

The utilization and release of dyes into the ecosystem have received great attention since approximately 9% (40,000 tons) of the dyes produced worldwide (450,000 tons) are discharged as textile waste water [6-7]. The occurrence of synthetic dyes in water after certain levels can significantly affect living beings by causing toxicity and mutagenicity. Therefore, analytical methods able to determine these synthetic dyes in industrial effluents, food, and water are of great interest to the research community.

Methods such as spectroscopy and chromatography [8-10] are tested to detect the dyes in the commercial samples. Unfortunately, these methods are laborious and time-consuming. In this context, electrochemical techniques, especially the voltammetric techniques, have been used as an alternative method due to the high selectivity, sensitivity, low cost, use of low-quantity sample, little or no sample treatment, and low waste generation, which contribute to reduced environmental impact [11-24].

Carbon paste electrodes (CPEs) belong to promising electrochemical or bio-electrochemical sensors with wide applicability for detecting various organic and inorganic molecules. In 1958, it was exactly 63 years before Ralph Norman Adams from the University of Kansas published a short one-page report in which he introduced CPE, initially, experiments were designed to develop a new electrode as an alternative to the dropping mercury electrode [11]. The first carbon paste was prepared by mixing 1 gram of carbon with 7 ml of bromoform. In the last decade variety of research had been done to improve the electrochemical performance of CPE and expand its application to detect a wide variety of analytes. In the below-mentioned table (Table 1), we are mentioning different working electrodes with their advantages and disadvantages.

The current form of CPE is quite different from Adams's work. The most widely used carbon material to prepare CPE is graphite powder apart from its variety of materials like graphene, carbon nanotube, and fullerene was also tested.

Currently, researchers are modifying CPE to further improve their properties like kinetics and stability. CPE can be modified mainly using three different methods like grinding, surface immobilization, and electro-deposition [19-24]. In the current chapter, we will mainly discuss the utilities of organic dyes modified (electro-deposited) CPE for sensing utilities.

Table 1. Advantages and disadvantages of different electrodes.

Electrode Materials	Advantage	Limitation
Pt	Available in dimension (as wire flat plate & tube). Large range of sizes. The rigidity can be improved (Pt-Rh alloy).	Expensive. Low hydrogen overvoltage so cathodic potential range limited.
Au	Configurations same as Pt. The larger cathodic potential range.	The larger cathodic potential range. The anodic window is limited by surface oxidation. Expensive.
Carbon	Many types and configurations. The good cathodic potential range.	Quality varies greatly. Hard to give shape.
Carbon-paste	Wide potential range. Low background current. Inexpensive.	Unstable in flow cells. Cannot use in organic solvents.
Hg	Excellent cathodic window. Easy to “refresh” Forms amalgams.	Limited anodic window due to mercury oxidation. Toxic.

PREPARATION OF ELECTRODES

To prepare an organic modified carbon paste modified electrode, CPE was placed in some electrolyte (buffer or bases like NaOH and KOH) solution. Electro-deposition can be (polymerization) was achieved by applying a potential of between to fixed potential (negative and positive) at a suitable scan rate for a few cycles using a method like cyclic voltammetry. After the electro-deposition, modified CPE was thoroughly washed with distilled water before electroanalysis. The electro-deposition process was pictorially represented in Fig. (1).

CHAPTER 14

Advanced Voltammetric Devices for Disease Detection

P. Sophiya¹, Deepadarshan Urs¹, Rajkumar S. Meti¹, H. A. Nagma Banu², J Shankar³ and K. K. Dharmappa^{1*}

¹ Department of Studies and Research in Biochemistry, Jnana Kaveri Post Graduate Centre, Mangalore University, Chikka Aluvara, Kodagu, Karnataka, India

² Course in Chemistry, Jnana Kaveri Post Graduate Centre, Mangalore University, Chikka Aluvara, Kodagu, Karnataka, India

³ Department of Studies and Research in Food Technology, Davangere University, Shivagangothri, Davangere, Karnataka, India

Abstract: Electroanalytical methods are beneficial in investigating the electrochemical characteristics of chemicals and macromolecules. The innovation of electrochemical sensors has been of tremendous interest owing to their high sensitivity, fast analysis and capability to analyse intricate samples; these properties make electrochemistry significant for its use in medical applications, especially in disease detection. The appropriate target analytes must be identified to recognize any diseases by electrochemical techniques and their interplay with biological cells needs to be investigated. In this chapter, we have explained an electrochemical approach and techniques for several disease detection.

Keywords: Biosensors, Disease detection, Electrochemical sensors, Voltammetry.

INTRODUCTION

Voltammetry is an electroanalytical technique derived from voltamperometry, which gives information about the analyte that helps measure the current by varying the voltage, *i.e.*, the electrode's potential. A voltammogram produces the plot by the change in the current produced by voltage variance. An electrochemical cell requires two electrodes, one electrode is made considerably smaller than the other so that the moving current is restricted only by this electrode, which is called the active electrode, and the second (larger) electrode is

* Corresponding author K. K. Dharmappa: Department of Studies and Research in Biochemistry, Jnana Kaveri Post Graduate Centre, Mangalore University, ChikkaAluvara, Kodagu, Karnataka, India-571232; Email: dharmappa@gmail.com

[†] First two authors have contributed equally.

called the auxiliary electrode [1]. Voltammograms vary largely with measurement time and thus, it is important to pay attention to time variables. The voltage is a controlled variable in conventional voltammetry, and the current is measured as a function of the applied voltage at a specific point in time [2].

Types of Voltammetry: Linear sweep, cyclic, square wave, stripping, alternating current (AC), pulse, steady-state microelectrode, and hydrodynamic voltammetry are the various types of voltammetry, characterised based on the mode of potential control. The cyclic voltammetry technique is widely used and operates on a time scale of seconds (CV). In contrast, the voltammetry currently in use is AC voltammetry at only a time scale of milliseconds. Here, we describe the hypothesis and tips for the practical application of mainly the two types of voltammetry (Fig. 1) [1].

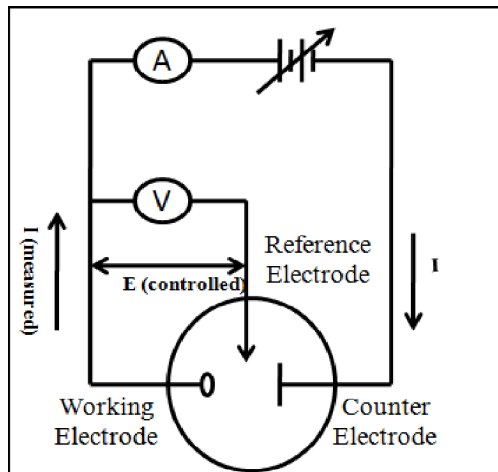

Fig (1). Schematic representation of cyclic voltammetry (Joshi PS *et al.*, 2018) [3].

Biosensors: Analytical devices that transform biological reactions into electrical signals are termed as biosensors. Biosensors should typically possess several properties such as reusability, precision and should not be affected by pH and temperature. The word “biosensor” was coined by Cammann [4] and IUPAC has introduced its definition [5 - 7].

The application of biosensors in the detection of blood biomarkers and proteins has received a lot of attention in diagnosing multiple diseases over the last decade [8, 9]. Biosensors with inexpensive advanced technology and low consumption of clinical samples are considered along with laboratory-based devices as a simpler clinical diagnostic tool [10, 11]. The invention of a genosensor for the detection of extremely sensitive DNA is currently of enormous interest in the discovery of

pathogenic diseases, clinical diagnostics and forensics with genomic DNA sequences/probes.

Voltammetric biosensors for cancer biomarkers detection: The electrochemical biosensors and the sort of electrochemical technique are employed to detect cancer biomarkers.

For example, 3D gold nanowire electrodes embedded in polypyrrole are used in Differential Pulse Voltammetry to detect prostate specific antigen concentrations of less than one femtogram per ml. Neuron-Specific Enolase (NSE) is a biomarker of lung cancer that can be detected by Glassy Carbon Electrodes (GCE) modified with gold nanocrystals at a concentration of 0.3 picograms per ml using cyclic voltammetry [12].

To detect HER2, a breast cancer biomarker by using Electrochemical Impedance Spectroscopy (EIS) at nanogram per ml, with a Carbon Ionic Liquid Electrode (CILE) [12]. This electrode is updated with multi-walled carbon nanotubes which enhances the biological recognition element's stability. Redox mediators such as the ferro/ferricyanide ion are used to maximise the efficiency of the biosensors. For a better prognosis, multiple biomarkers have to be analysed concurrently. Therefore, the use of multiple working electrodes or a single electrode with multiple labeling of antibodies is convenient [13].

The Human Epidermal growth factor Receptor 2- Extra Cellular Domain (HER2-ECD) is a breast cancer biomarker, which can be quantified by electrochemical molecularly imprinted polymer (MIP) sensor. The MIP is developed by electropolymerisation with a solution containing phenol and HER2-ECD on a screen-printed gold electrode (AuSPE) by using cyclic voltammetry. In addition, analysis of human serum samples by cyclic voltammetry and electrochemical impedance spectroscopy for the precise result is mandated. Thus MIP sensor could be useful in the analysis of HER2-ECD in breast cancer patients [14].

Lung cancer is gene associated disease; the genosensor is required to detect single point EGFR (Epidermal Growth Factor Receptor) gene variation. In the detection of DNA hybridisation, voltammetry detection was recognised as one of the strongest detective methods. When the genomic biomarkers bear, the charge was translated into a readable signal. In comparison to other sensing techniques, voltammetry genosensor is chosen because of its fast response, minimal effort in the invention with affordable prices and is less time consuming [15, 16].

The limit of detection and enhanced sensitivity by immobilising the least quantity of DNA samples on the sensing surface are the two primary problems in the development of the genosensor. For the excellent hybridisation and immobi-

Advanced Materials for Immune Sensors

A.H. Sneharani^{1,*}

¹ DoS in Biochemistry, Jnana Kaveri P.G. Center, Mangalore University, Karnataka 571232, India

Abstract: The chapter outlines the trends in the rapid development of biofunctionalized hybrid nanomaterials for application as immune sensors to detect biomarkers, the hallmarks of diseases. Biofunctionalized advanced materials incorporate biological macromolecules/biomaterials with high specificity and selectivity, such as proteins with unique binding properties which are combined with the electronic, optical or photonic properties of nanostructures, enabling them to function as sensors. Functionalization materialises due to similarity in dimension scale allowing functional coupling leading to an effective signal transduction in these sensors. A variety of nano objects metals, carbon nanotubes are coupled with proteins/immunoglobulins or antigens to yield biofunctionalized advanced materials leading to the development of promising novel immune biosensors with many advanced features, like ergonomic, time saving, sensitivity, point-of-care cost economy, feasibility and reproducibility.

Keywords: Antibody, Antigen, Diagnostics, Functionalization, Immunosensors, Nanomaterials.

INTRODUCTION

Biosensors are advanced diagnostic tools that measure and give quantitative output signals about the concentration of the target analyte in the sample. Analytes are components to be detected in the biological sample. They have a biological origin, range from genetic material (DNA or RNA), have proteins of pathogenic bacteria or viruses, proteins or other biological molecules secreted during pathological conditions and immunoglobulins (proteins) synthesized from the immune response of the infected person. Simple molecules like glucose and ions also can be detected. In some cases, the analyte is also known by the term biomarker. The recognition and detection of an analyte in a biosensor occur due to the specific recognition of the target analyte with the immobilised biomolecule often termed as bioreceptor. The bioreceptor is usually the complementary comp-

* Corresponding author A.H. Sneharani: DoS in Biochemistry, Jnana Kaveri P.G. Center, Mangalore University, Karnataka 571232, India; Tel: +91 9945566321; Email: sneharaniah@gmail.com

onent of the analyte which is often an enzyme, monoclonal antibody, DNA, RNA, lectin, glycan or whole cell. Bioreceptors are very crucial elements in designing biosensors, as they provide high sensitivity and specificity in recognising the biomarker present in the sample. Bioreceptor specifically interacts with the target analyte either through covalent or non-covalent interactions generating a signal in the form of heat, charge or change in pH or mass change. The signal generated by these biorecognition events between the biomarker/ analyte and the bioreceptor is converted into a quantitatively measurable signal by transducers. The recorded signal allows the detection and identification of pathogen or disease conditions. A schematic diagram of the principle and design of biosensor is given in Fig. (1). Biosensors are very sensitive devices allowing the analyte to detect sub-micro molar concentration, hence requiring a sample in minute amounts. A sensor that is specifically used to detect the immune components comprises the immunosensor. These are ligand based sensing devices which recognise biological molecules by specific affinity interactions. Immunosensors work on the general principle based on the specific immunochemical recognition of antigens or antibodies immobilized on the transducer to antibodies or antigens respectively present in the sample.

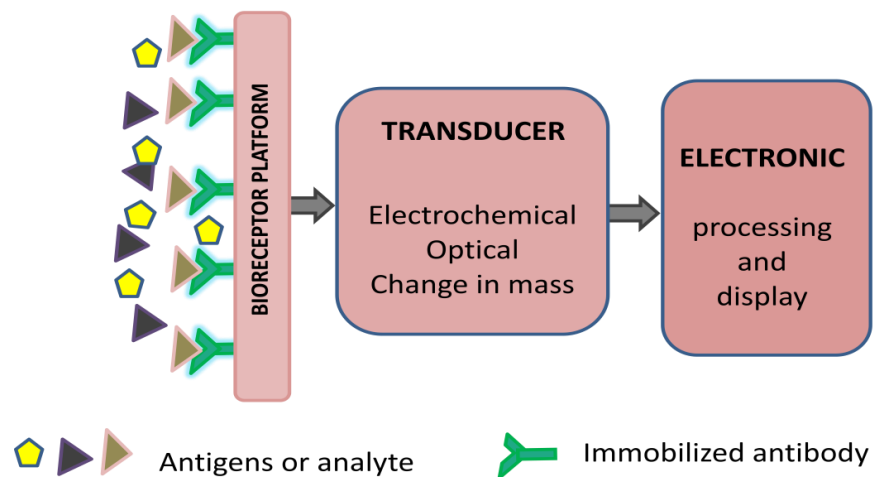

Fig. (1). Schematic diagram of the principle and design of biosensor.

IMMUNE COMPLEX

The cells and molecules responsible for protecting from foreign substances or infectious diseases constitute the immune system. The collective and co-ordinated physiological response of the immune system against foreign substances is called an immune response. Immune response mechanism normally protects individuals from infectious agents and eliminates foreign substances; however, under certain conditions, the same mechanism may cause tissue injury and disease. Defense

against foreign substances by early response comprise ‘innate immunity’ and later responses called ‘adaptive immunity’. Innate immunity provides early defense against microorganisms. The mechanisms are in place before even the onset of infection and the response is faster. The immune response in adaptive immunity is stimulated by exposure to infectious agents in response to infection which increases in magnitude with each successive exposure. Cellular and chemical barriers in case of innate immunity include skin, mucosal epithelia and antimicrobial chemicals, whereas, in adaptive immunity, lymph cells and their secreted products such as antibodies bring about the immune response [1, 2]. Adaptive immunity is characterised by exquisite specificity towards a large number of different or closely related molecules and microbes. Foreign substances that elicit immune response are called antigens. The adaptive immune response is mediated *via* humoral and cell mediated immunity. Humoral immunity is mediated by molecules in the blood called antibodies. Antibodies very specifically recognise microbial antigens and help in eliminating the microbes and toxins from the body. Humoral immune response is the principal defence mechanism in eliminating the extracellular microbes by secreting the antibodies. Intracellular microbes such as viruses and some bacteria survive and proliferate in host cells such as phagocytes where they are inaccessible to circulating antibodies. Defense against such infectious agents is mediated by cell mediated immunity which acts in eliminating the cells which are reservoirs of infectious agents.

Antibodies are glycoproteins that belong to the immunoglobulin (Ig) superfamily. The distinctive structure of an antibody is its Y-shape, comprising two pairs of polypeptide chains known as heavy and light chains which are identical. The light and heavy chains are linked through the disulphide linkage. The antibody structure is distinguished typically into three regions; two Fabs (fragment antigen binding) and one Fc (fragment crystallisable). The recognition and binding of antibodies on a specific site on the antigen is called an epitope. The specific binding of the antibody towards epitope is through Fab fragment. The antibody with a wide range of specificities for different epitopes of the same antigen is called a polyclonal antibody. On the other hand, antibodies displaying high specificity and affinity for a particular epitope is called a monoclonal antibody. A key milestone in the development of immunoassays was developed by the advent of hybridoma method of antibody production. By this method, monoclonal antibodies are developed to detect antigens with specific and desired epitopes. The continuous production of monoclonal antibodies through hybridoma technology opened avenues in the field of immunodiagnosics.

SUBJECT INDEX

A

- Ability 42, 207
 anti-interference 42
 electroanalytical 207
- Acid(s) 8, 18, 19, 22, 24, 32, 33, 38, 39, 41, 42, 43, 44, 50, 70, 75, 80, 83, 85, 86, 88, 127, 138, 158, 159, 184, 187, 195, 205, 206, 219, 224, 233, 244, 247, 251, 264, 269, 282, 308, 326, 356, 358, 361
- acetic 264
 adipic 8
 anthranilic 264
 arachidonic 269
 ascorbic (AA) 18, 22, 24, 32, 38, 41, 43, 44, 85, 127, 184, 206
 chloroacetic 361
 citric 8
 copper benzenetricarboxylic 39
 enolic 264
 fatty 219
 folic 308
 Gallic 8, 33
 Gamma-Aminobutyric 80
 hydrochloric 138
 mycophenolic 18, 19
 mineral 224, 251
 nitric 195
 nucleic 70, 75, 83, 86, 88, 158, 159, 205, 356
 pimelic dicarboxylic 50
 ribonucleic 358
 salicylic 264
 sulfonic 326
 uric (UA) 24, 41, 42, 187, 247, 282, 333
- Activity 105, 118, 179, 186, 189, 217, 359
 electroanalytical 186
 flavoprotein enzyme 118
- Adsorption 7, 13, 30, 31, 41, 105, 135, 186, 201, 206, 207, 221, 235, 359
 desorption isotherms 221
 direct physical-chemical 235
 hydrophobic 359
 isotherm 7
- Alkaline phosphatase 75
 Alkylating agent 298
 Alzheimer's 342, 344, 345, 357
 biomarkers 344
 disease 342, 345, 357
- Amperometric detection 288
 Analysis 233, 245, 248, 357
 antihypertensive 245, 248
 electrogravimetric 233
 forensic 357
- Analytical methods 65, 69, 74, 91, 233, 262, 326, 330
 traditional 65
- Analytical principle of electrochemical biosensors 75
- Analytical signals 22, 73, 234, 235, 240, 248, 355
 measurable 73
- Analytical techniques 181, 201
 sensitive 181
- Analyzing enzyme-based sensors 110
- Angiotensin-converting enzyme (ACE) 232, 250
 inhibitors 250
- Ankylosing spondylitis 269
- Anodic stripping voltammetry (ASV) 10, 36, 104, 183, 184, 191, 235, 282
- Antigen-antibody reaction 356
- Apolipoprotein E (APOE) 342
- Applications 3, 19, 32, 34, 41, 47, 71, 359, 362, 363
 biosensing 41, 47, 362
 chemical recognition 71
 drug analysis 3
 electroanalytical 19
 electrochemical 32, 34
 immunodiagnostic 363
 immunosensing 359, 362
 immunosensor 362
- Aspergillus terreus* 48

Atomic absorption spectroscopy (AAS) 181, 206

B

Bare carbon paste electrode (BCPE) 123, 124

Biofuel cells 203, 204
enzymatic 204

Biofunctionalized materials 357, 360

Biosensor(s) 5, 48, 65, 66, 69, 73, 75, 76, 77, 79, 80, 81, 82, 83, 87, 90, 111, 112, 158, 159, 161, 162, 168, 189, 340, 341, 343, 345, 352

acetylcholinesterase 189

aggregation-based 73

commercial POC 87

detection system 75

device 73

diagnostic 73, 90

electro-chemical 341

enzymatic 73, 80, 159, 162

enzyme-based 79, 80, 111, 112

fabricating 5

potentiometric 76, 77

Biosensor applications 67, 74, 76, 363
microfluid 74

Boron-doped diamond electrode (BDDE) 243, 244, 245, 248, 251, 268, 287, 288, 310

Bovine serum albumin 203

Brain disorders 80

C

Camellia sinensis 48

Cancer 82, 83, 298, 299, 306, 307, 310, 312, 314, 341, 344, 345, 357, 359

breast 82, 83, 312, 344, 357

colorectal 312

esophageal 82

kidney 82

liver 82

lung 82, 341

metastatic testicular 298

ovarian 82, 312

pancreatic 82

skin 82

thyroid 82

Carbon 11, 12, 22, 23, 25, 66, 67, 70, 121, 122, 191, 192, 199, 202, 204, 362, 363

nano horns (CNHs) 199, 204

nanomaterials (CN) 11, 12, 22, 23, 25, 66, 67, 70, 121, 122, 191, 192, 202, 362, 363

Cardiotoxicity 312, 313

Cardiovascular events 231

Catalysed terminal alkyne-azide cycloaddition reaction 361

Catalysis 2, 47, 48, 75, 190

Catalytic 7, 70, 118, 124, 186, 187, 189, 200
activity 70, 124, 187, 189, 200

Cathodic stripping voltammetry method 345

Charge balance theory 147

Charge-discharge processes 145

Chemical 134, 137

bond analysis 134

compositional analysis 137

Chemically modified electrodes (CME) 1, 237

Chromatography 80, 326, 328, 346

Chronoamperometry 179, 262

CNTP 268

nanocomposite 268

nanoparticle 268

Computed tomography (CT) 39, 40, 344

Conducting polymers (CPs) 1, 2, 41, 201

Conductometry 178

Coronavirus disease 343

COVID-19 344

diagnosis 344

monoclonal 344

Cyclooxygenase 269

D

Detection 69, 79, 88, 137, 177, 181, 183, 187, 194, 264, 283, 306, 345

and determination of heavy metals 181

anti-interference 183

cooled double beam 137

Subject Index

electrochemical 69, 79, 88, 187, 264, 283, 306
heavy metal 177, 194
of mismatched base pairs in DNA 88
of viral genome of Hepatitis 345
Detection methods 78, 83
colorectal cancer 83
Devices 51, 89, 112, 135, 189, 204, 208, 216
efficient DNA biosensing analysis 89
electrochromic 135
electrode-based sensor 51
electronic 216
energy harvesting 135
enzyme-based biosensing 112
nanogenerator-based 204
optoelectronic 189
sensory 208
Diabetes mellitus 159
Diseases 8, 64, 65, 78, 81, 82, 83, 85, 87, 158, 159, 165, 167, 231, 291, 293, 333, 344, 345, 352, 353, 358, 359
autoimmune 359
cardiovascular 83, 87, 167, 231, 291, 333
chronic respiratory 8
inflammatory rheumatic 293
Disorders 127, 264
inflammatory 264
neurological 127
DNA 15, 16, 76, 88, 163, 167, 168, 167, 176, 182, 188, 189, 205, 206, 341, 342, 343, 352, 353
based materials for heavy metal ion 206
biosensor 76
complementary 167
hairpins 205
hybrid 163
hybridisation 341
immobilisation 342
recognition 167

E

EIAs, flow cytometry 87

Voltammetry for Sensing Applications 369

Electrical 2, 6, 7, 22, 66, 67, 69, 70, 71, 120, 148, 178, 179, 191, 192, 193, 201, 206, 236, 344
conductivity 6, 66, 67, 69, 70, 71, 120, 191, 344
properties 2, 7, 22, 66, 69, 70, 192, 193, 201, 236
resistance 148
response 178, 179, 206
Electroanalysis 39, 108, 109, 233, 239, 248, 327, 328, 330
of antihypertensive drugs 233
of marker dyes 330
of textile dyes 328
Electroanalytical 178, 179, 230, 231, 235, 281, 133, 235, 281, 245, 325, 328, 339
methods 230, 231, 245, 325, 328, 339
techniques 178, 179, 233, 235, 281, 339
Electrocatalysis 26, 30
Electrocatalytic activity 41, 122, 192, 271, 306
Electrochemical 6, 16, 17, 19, 64, 65, 103, 111, 112, 117, 120, 121, 122, 146, 148, 160, 177, 181, 202, 206, 207, 233, 259, 285, 286, 288, 289, 290, 291, 293, 295, 297, 298, 300, 339, 341, 342, 344, 346
biosensing methods 65
biosensor technology 64
impedance spectroscopy (EIS) 6, 16, 17, 19, 117, 120, 121, 146, 148, 202, 341, 342, 344
oxidation 285, 286, 288, 289, 290, 291, 293, 295, 297, 298, 300
polymerization 122
process 103, 112
techniques 111, 160, 177, 181, 206, 207, 233, 259, 339, 341, 346
voltammetric impedance analysis 146
Electrochemical analysis 65, 66, 74, 78, 215, 330
high-performance 65, 66
Electron beam deposition method 134
Electronic impedance spectroscopy 117
Electrooxidation pathway 250
Electro polymerisation technique 119

Electropolymerization method 331
Enzymes 17, 18, 33, 48, 49, 66, 67, 71, 74, 75,
87, 158, 159, 160, 202, 203, 204, 205,
206, 344, 356, 357
horseradish peroxidase 17, 18
immunoassays 75
linked immunosorbent assay (ELISA) 87,
344, 357
immobilizing glucose oxidase 33
proteolytic 71
Epidermal growth factor receptor (EGFR)
341, 344, 357

F

Fever, dengue 85
Flavin adenine dinucleotide (FAD) 118
Flow injection analysis (FIA) 181, 287, 288
Fuel cell-based self-powered 203
electrochemical sensors 203

G

Galvanostatic charge-discharge (GCD) 145,
146
Genetic disorder 159
Glassy carbon electrode (GCE) 19, 32, 33,
109, 236, 237, 238, 239, 245, 283, 284,
286, 288, 290, 292, 294, 296, 297, 309,
329
Glutamate dehydrogenase 162
Gold nanoparticles 81, 183, 199, 200, 298,
311, 312, 344, 345, 357, 360, 362
electrodeposition of 199, 200
fabricated porphyrin-capped 311
Graphene quantum dots (GQD) 46, 311
Green 47, 217, 222, 233, 360
combustion method 217, 222, 223
fluorescence protein (GFP) 360
techniques 47

H

Hanging mercury drop electrode (HMDE)
106, 107, 314
Headache 290, 334
Heavy metal pollutants 180, 183, 190
Hemodialysis 239
Hepatitis 36, 85, 343, 345, 357
chronic 36
viral 85
Hexafluorophosphate 313
ionic liquid octylpyridinium 240
Homeostasis 159
Human immunodeficiency virus (HIV) 87, 88
Hydrochlorothiazide 236, 237, 238, 239, 240,
241, 242, 243, 244, 245, 246, 247, 248,
249, 250
diuretic 237
Hydrothermal 4, 8, 136, 141 186, 187
method 4, 8, 136, 186, 187
synthesis 186

I

IBP oxidation process 40
Immune 86, 343, 352, 353, 354, 357
biosensors 343, 357
response 86, 352, 353, 354
Immunoanalytical technique 357
traditional 357
Immunoassays 343, 354, 357, 359
sandwich 343
Immunochemical reactions 359
Immunoliposomes 68
Immunonephelometry 357
Immunosensors 75, 159, 163, 353, 355, 356,
357, 358, 359, 360, 363
electrochemical 356
Infection, wound 342
Infectious diseases 85, 86, 353, 357
Insulin 343
detection 343
production 343
Ionic liquid 183, 200, 240, 288, 292, 309

Subject Index

vulcan carbon/conductive polymeric 292
Ion-selective electrodes (ISE) 77
Irradiation 141, 142
 microwave 141
Irritation, rheumatoid joint 269

J

Juvenile kidney 267

K

Kidney disease 78, 83, 167, 231
 chronic 167, 231
 diabetic 83

L

Leukaemias 312, 315
Linear range sensitivity 79
Localised surface plasmon resonance (LSPR)
 362

M

Magnetic glassy carbon electrodes (MGCE)
 184, 188
Malaria parasites 86
Mass 31, 206
 spectrometry 206
 transfer process 31
Mechanisms 124, 177, 178, 181, 202, 205,
 224, 231, 232, 250, 345, 346, 353, 354
 adsorption-controlled 124
 antihypertensive 232
 electrochemical 250
 electrooxidation 250
Mesoporous carbon spheres (MCS) 313
Metallic precursors 4
Metal 5, 189
 nanocomposites 189
 nanostructures in sensors 5

Voltammetry for Sensing Applications 371

Metal nanoparticles 1, 2, 5, 70, 72, 79, 182,
 183, 184, 199, 206, 208, 362
 in electrochemical sensing 183
Metal-organic framework(s) (MOFs) 38, 39,
 40, 74, 182, 190, 191
 carbon nanofiber 40
 construction 39
Methods 27, 109, 178, 247, 259, 260, 264,
 317, 325, 328, 329, 330, 354
 chromatography 247
 electrochemical 109, 259, 260, 264, 317,
 325, 328, 329, 330
 hybridoma 354
 potentiometric 178
 reduction-precipitation 27
Methotrexate sensor 310
Mineral oil 239, 240
 agglutinating material 240
Molecularly imprinted polymers (MIPs) 44,
 45, 46, 47, 74, 201, 202, 207, 208, 290,
 341
Mycobacterium tuberculosis 297

N

Non-steroidal anti-inflammatory drugs
 (NSAIDs) 259, 264, 266, 269
Nucleic acid amplification tests (NAATs) 87

O

Oligonucleotides, electroactive 163
Oxidase 44, 162, 203, 204, 205
 ascorbate 44
 bilirubin 204
 cholesterol 162
 galactose 162
 lactate 162
Oxidation 29, 30, 40, 76, 104, 105, 193, 203,
 204, 206, 234, 236, 238, 242, 243, 250,
 266, 268
 copper-catalyzed 206
 enzyme-catalyzed 204
 photocatalytic 203

Oxidation processes 17, 36, 237, 240, 290, 295
 electrochemical 295
 observed electrochemical 290
Oxidative 181, 247
 processes 247
 stress 181

P

Pencil graphite electrode (PGE) 331
Periodic bodily fluid 168
Peroxidase, horseradish 75, 362
Pharmaceutical 2, 18, 24, 118, 231, 247, 251, 264, 284
 industry 18, 231, 247, 251, 264
 preparations 2
 products 24, 118, 284
Photocatalysis 136, 216
Photocatalysts 203, 204, 216, 224
 semiconducting 203
Photocatalytic 135, 218, 215, 220, 221, 223, 224
 activity 135, 218, 220, 224
 degradation 223, 224
 performance 215
 process 224
 reactions 221
Photo-electrochemical properties 48
Polymerase chain reaction (PCR) 78, 85, 87, 88
Polymer-based 41, 201
 electrochemical sensors 201
 Nanosensors 41
Polymerization 46, 164, 202, 327
 chemical oxidative single step 46
 electrodeposition/electrochemical 164
Polymorphic four-stranded structure 206
Potentiometric 77, 78, 162, 356
 signal generation process 77
Potentiometric stripping 192, 282
 analysis 192
 voltammetry (PSV) 282

Powder X-ray diffractometer (PXRD) 215, 218, 219
Power 108, 137, 203
 adsorbing 108
 electrical 203
Procedure 18, 109, 112
 electroanalytical 109, 112
 electrode preparation 18
Properties 6, 11, 12, 19, 20, 26, 27, 31, 32, 50, 70, 72, 73, 136, 201, 206, 207, 260, 291, 331, 339, 340, 358, 359, 360
 antioxidant 50
 antipyretic 291
 biological 72
 electrocatalytic 6, 201, 207
 electro-chemical 136
 intrinsic 358
 kinetic 331, 360
 luminescence 359
 photochromic 136
 thermodynamic 260
Prostate cancer 82
Protein(s) 74, 75, 76, 83, 86, 158, 159, 160, 163, 164, 167, 344, 352, 358, 359, 360, 361, 362
 anchor 362
 cancer biomarker 344
 green fluorescence 360
 biomarkers 83
 Isolation 167
PXRD Analysis 218, 225

Q

Quantum dots 2, 48, 309, 384, 363
 cadmium telluride 284
 co-doped carbon 309
Quasi-reversible reaction 125

R

Radio frequency (RF) 136
Radiotherapy 306
Rapid diagnostic tests (RDTs) 86, 87

Subject Index

RB analysis process 124
Renin-angiotensin-aldosterone system (RAAS) 232, 250
Respiratory syndrome 85
Reverse transcriptase-polymerase chain reaction (RT-PCR) 344, 358
Reversible voltammetric reactions 110
Rheumatoid arthritis (RA) 87, 264, 293, 332
RNA 160, 167, 310, 310, 345, 352, 353, 358
 dependent RNA polymerase 345
 exosomal 167
 isolated 167
 nuclear 310
 preparation method 358
 sequencing 167
RT-PCR 344, 358

S

SARS-CoV-2 345, 358
 antigen 345
 spike protein 358
 virus 358
Scanning electron microscope 215
Scanning electron microscopy 134, 344, 117
 electro-chemical impedance spectroscopy 344,
 field emission 117
Scherer's formula 218
Schizophrenia 333
Screen-printed 5, 39, 40, 42, 43, 177, 183,
 198, 199, 200, 207, 208, 242, 243, 283,
 284, 287, 296, 298, 309, 310
 carbon electrode (SPCEs) 5, 40, 43, 183,
 199, 200, 283, 284, 287, 296, 298
 electrochemical sensors 177, 198
 electrodes (SPEs) 39, 42, 198, 199, 200,
 207, 208, 242, 243, 309, 310
Semiconductor photocatalysts 216
Sensing 2, 70, 79, 206, 273, 317, 341, 344,
 184
 heavy metal pollutants 184
 properties, electrochemical 2
 systems 344

Voltammetry for Sensing Applications 373

 techniques 70, 206, 341
 electrochemical 273, 317
 technology 79
Sensing devices 5, 103, 106, 112
 electrochemical 112
Sensors 24, 27, 48, 73, 88, 110, 112, 128, 179,
 192, 186, 203, 201, 205, 206, 245, 248,
 267, 268, 270, 271, 283, 309
 efficient electrochemical 27, 186
 electrochemical methotrexate 309
 electrochemiluminescence 203
 electronic tongue 112
 enzyme-based 110, 205
 enzyme-based electrochemical 205
 fabricated 24, 128
 heat-sensitive 73
 heavy metal 206
 immuno 283
 nanocomposite 267, 268, 270
 nanocomposite-based electrochemical 197
 nanotube-based electrochemical 192
 nucleic acid-based 205
 polymer-based 201
 polypyrrole-based 201
 robust electrochemical 245, 248
 sensitive 88, 268, 271
 spherical Electrochemical 48
Signals, amplified electrochemical
 immunoassays 68
Silicon nitride film (SNF) 270, 271
Sol-gel technique 4
Spectrophotometric analysis 91
Spectroscopy 181, 206, 326
 atomic absorption 181, 206
Square wave anodic stripping voltammetry (SWASV) 182, 183, 184, 197, 199
Static mercury drop electrode (SMDE) 106,
 107
Stripping voltammetry (SV) 10, 36, 104, 112,
 183, 184, 191, 235, 239, 281, 282
Succinic anhydride 361
Surface plasmon resonance (SPR) 16, 17, 73,
 82, 356
SWV 32, 246, 284, 285
 method 32, 246

technique 284, 285
Systems 75, 81, 127, 181, 233, 333, 353, 359
dopaminergic 127
electronic 233
hormonal 333
hybrid conjugate 359
immune 75, 353
intelligent diagnostic 81
nervous 181, 333

T

Techniques 181, 357
electrochemical-based 181
immunoassay 357
Technology 201, 202, 360, 363
immunosensing 363
screen-printed electrode 201, 202
Tests 83, 86, 87, 343, 344, 355, 358
blood-based liquid biopsy 83
nucleic acid amplification 87
protein-based blood 83
Thermal 7, 13, 196
decomposition 196
gravimetric analysis (TGA) 7, 13
Treatment 83, 87, 187, 232, 236, 302, 307
antihypertensive 232
antiretroviral 87
chemotherapeutic 307
heat 187
laser 236
oral rinse 83
Tumour biochemistry 310

U

UV 137, 142, 218, 225,
irradiation 225
visible absorption 218
visible spectral analysis 142
visible spectroscopy 137

V

Veterinary drug 31
Viral load screening 87
Volatile organic compounds (VOCs) 345
Voltammetric 15, 104, 134, 159, 160, 287,
328, 345
assays 15
Biosensor 159, 160, 345
cells 104, 328
determination of erythromycin 287
electrochemical 134
Voltammetric determination 126, 134, 137,
146, 148, 237, 284, 287, 291, 292, 293
electrochemical 134, 146, 148
Voltammetric 103, 106, 110, 111, 230, 231,
236, 238, 241, 243, 246, 247, 249, 259,
260, 281, 283, 284
devices 106
electrodes 103
materials 111
methods 230, 231, 236, 238, 241, 243, 246,
247, 249, 259, 260, 281, 283, 284
processes 110
Voltammetric sensors 41, 76, 103, 109, 112,
192, 242, 244, 259
striping analysis 192
Voltammetric techniques 103, 104, 112, 231,
233, 234, 259, 260, 281, 282, 283, 292
employing square wave 292
Voltammetry 260, 281, 282, 300, 340, 345
hydrodynamic 340
technique 260, 281, 282, 300, 345
Voltammograms 105, 109, 122, 261, 262, 339,
340

W

Water pollutants 112

X

X-ray 7, 20, 25, 28, 134, 135, 137, 152

Subject Index

diffraction (XRD) 7, 20, 25, 28, 134, 135,
137, 152
diffractometer instrument 137
photoelectron spectroscopy 137
XRD analysis 139

Z

Zinc oxide nanoparticles 43

Voltammetry for Sensing Applications 375



J. G Manjunatha

J. G Manjunatha is working as an Assistant Professor in Chemistry at FMKMC College, a Constituent College of Mangalore University, Madikeri, India. He received his Ph.D. degree in Chemistry from Kuvempu University and Postdoc from the University of Kebangsaan Malaysia. He has received various awards and published more than 128 research articles in reputed international journals. His research interests focus on the fabrication of electrochemical sensors to detect biologically active molecules and the fabrication of binderless Supercapacitor.