

# PRACTICAL HANDBOOK OF THERMAL FLUID SCIENCE

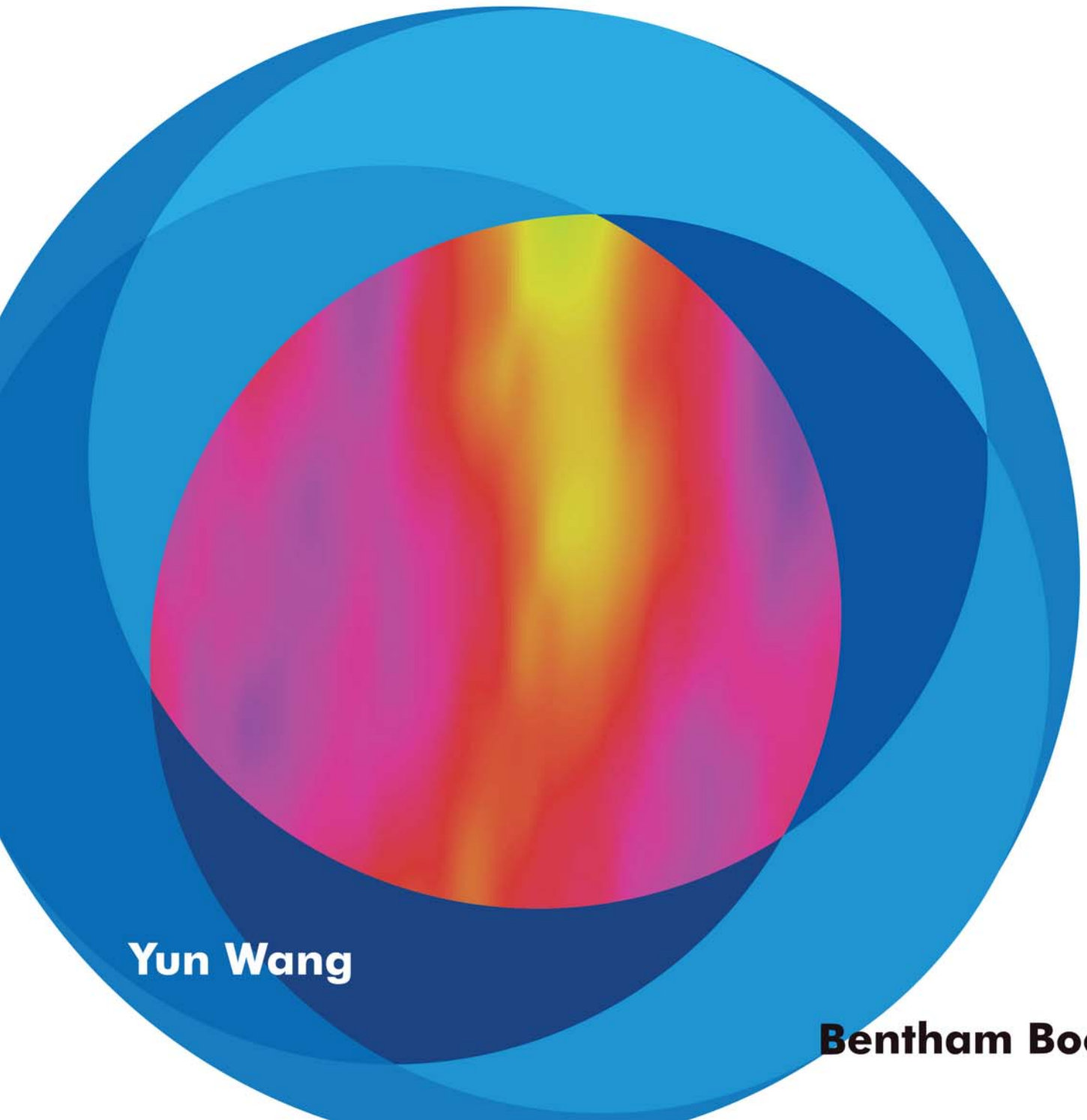

**Yun Wang**

**Bentham Books**

# **Practical Handbook of Thermal Fluid Science**

**Authored by**

**Yun Wang**



## **Practical Handbook of Thermal Fluid Science**

Author: Yun Wang

ISBN (Online): 978-1-68108-919-5

ISBN (Print): 978-1-68108-920-1

ISBN (Paperback): 978-1-68108-921-8

© 2023, Bentham Books imprint.

Published by Bentham Science Publishers – Sharjah, UAE. All Rights Reserved.

First published in 2023.

## **BENTHAM SCIENCE PUBLISHERS LTD.**

### **End User License Agreement (for non-institutional, personal use)**

This is an agreement between you and Bentham Science Publishers Ltd. Please read this License Agreement carefully before using the ebook/echapter/ejournal (“**Work**”). Your use of the Work constitutes your agreement to the terms and conditions set forth in this License Agreement. If you do not agree to these terms and conditions then you should not use the Work.

Bentham Science Publishers agrees to grant you a non-exclusive, non-transferable limited license to use the Work subject to and in accordance with the following terms and conditions. This License Agreement is for non-library, personal use only. For a library / institutional / multi user license in respect of the Work, please contact: [permission@benthamscience.net](mailto:permission@benthamscience.net).

### **Usage Rules:**

1. All rights reserved: The Work is the subject of copyright and Bentham Science Publishers either owns the Work (and the copyright in it) or is licensed to distribute the Work. You shall not copy, reproduce, modify, remove, delete, augment, add to, publish, transmit, sell, resell, create derivative works from, or in any way exploit the Work or make the Work available for others to do any of the same, in any form or by any means, in whole or in part, in each case without the prior written permission of Bentham Science Publishers, unless stated otherwise in this License Agreement.
2. You may download a copy of the Work on one occasion to one personal computer (including tablet, laptop, desktop, or other such devices). You may make one back-up copy of the Work to avoid losing it. The following DRM (Digital Rights Management) policy may also be applicable to the Work at Bentham Science Publishers’ election, acting in its sole discretion:
  - 25 ‘copy’ commands can be executed every 7 days in respect of the Work. The text selected for copying cannot extend to more than a single page. Each time a text ‘copy’ command is executed, irrespective of whether the text selection is made from within one page or from separate pages, it will be considered as a separate / individual ‘copy’ command.
  - 25 pages only from the Work can be printed every 7 days.
3. The unauthorised use or distribution of copyrighted or other proprietary content is illegal and could subject you to liability for substantial money damages. You will be liable for any damage resulting from your misuse of the Work or any violation of this License Agreement, including any infringement by you of copyrights or proprietary rights.

### ***Disclaimer:***

Bentham Science Publishers does not guarantee that the information in the Work is error-free, or warrant that it will meet your requirements or that access to the Work will be uninterrupted or error-free. The Work is provided "as is" without warranty of any kind, either express or implied or statutory, including, without limitation, implied warranties of merchantability and fitness for a particular purpose. The entire risk as to the results and performance of the Work is assumed by you. No responsibility is assumed by Bentham Science Publishers, its staff, editors and/or authors for any injury and/or damage to persons or property as a matter of products liability, negligence or otherwise, or from any use or operation of any methods, products instruction, advertisements or ideas contained in the Work.

### ***Limitation of Liability:***

In no event will Bentham Science Publishers, its staff, editors and/or authors, be liable for any damages, including, without limitation, special, incidental and/or consequential damages and/or damages for lost data and/or profits arising out of (whether directly or indirectly) the use or inability to use the Work. The entire liability of Bentham Science Publishers shall be limited to the amount actually paid by you for the Work.

### **General:**

1. Any dispute or claim arising out of or in connection with this License Agreement or the Work (including non-contractual disputes or claims) will be governed by and construed in accordance with the laws of the U.A.E. as applied in the Emirate of Dubai. Each party agrees that the courts of the Emirate of Dubai shall have exclusive jurisdiction to settle any dispute or claim arising out of or in connection with this License Agreement or the Work (including non-contractual disputes or claims).
2. Your rights under this License Agreement will automatically terminate without notice and without the need for a court order if at any point you breach any terms of this License Agreement. In no event will any delay or failure by Bentham Science Publishers in enforcing your compliance with this License Agreement constitute a waiver of any of its rights.
3. You acknowledge that you have read this License Agreement, and agree to be bound by its terms and conditions. To the extent that any other terms and conditions presented on any website of Bentham Science Publishers conflict with, or are inconsistent with, the terms and conditions set out in this License Agreement, you acknowledge that the terms and conditions set out in this License Agreement shall prevail.

**Bentham Science Publishers Ltd.**

Executive Suite Y - 2

PO Box 7917, Saif Zone

Sharjah, U.A.E.

Email: [subscriptions@benthamscience.net](mailto:subscriptions@benthamscience.net)



## CONTENTS

PREFACE .....	i
SYMBOLS .....	iii
GREEK .....	v
<b>CHAPTER 1 INTRODUCTION</b> .....	1
1.1. INTRODUCTION TO THERMODYNAMICS, FLUID FLOW, AND HEAT TRANSFER .....	1
1.2. EXPERIMENTAL MEASUREMENT .....	2
1.3. EXPERIMENTAL TEST PLAN AND STANDARD OF PROCEDURE .....	4
1.4. EXPERIMENT AND LABORATORY SAFETY .....	6
1.5. QUESTIONS .....	12
REFERENCES .....	13
<b>CHAPTER 2 ANALYSIS OF EXPERIMENTAL DATA</b> .....	15
2.1. INTRODUCTION .....	15
2.2. ERROR AND UNCERTAINTY ANALYSIS .....	15
2.3. PROBABILITY DISTRIBUTION .....	19
2.4. OUTLIERS AND THREE SIGMA TESTING .....	27
2.5. EXPERIMENT .....	29
2.6. QUESTIONS .....	33
REFERENCES .....	34
<b>CHAPTER 3 HEAT TRANSFER</b> .....	36
3.1. INTRODUCTION .....	36
3.2. TEMPERATURE MEASUREMENT .....	37
3.3. HEAT FLUX .....	39
3.4. LUMPED HEAT CAPACITY ANALYSIS .....	41
3.5. EXPERIMENT .....	48
3.6. 3-D NUMERICAL ANALYSIS .....	55
3.7. QUESTIONS .....	56
REFERENCES .....	58
<b>CHAPTER 4 POWER PLANT</b> .....	60
4.1. INTRODUCTION .....	60
4.2. STEAM TURBINE POWER GENERATION .....	61
4.3. GAS TURBINE POWER GENERATION .....	64
4.4. CHILLER AND THERMAL ENERGY STORAGE TANK .....	66
4.5. BALANCE OF PLANT .....	67
4.6. MAJOR COMPONENTS IN A POWER PLANT .....	68
4.7. QUESTIONS .....	79
REFERENCES .....	80
<b>CHAPTER 5 PIPE FLOW AND FLOW METERING</b> .....	81
5.1. INTRODUCTION .....	81
5.2. PRESSURE MEASUREMENT .....	81
5.3. FLOW METER: VENTURI TUBE AND ORIFICE PLATE .....	84
5.4. PIPE FLOW .....	88
5.5. FRICTION FACTOR AND MOODY CHART .....	90
5.6. EXPERIMENT .....	95
5.7. QUESTIONS .....	99
REFERENCES .....	100
<b>CHAPTER 6 EFFICIENCIES IN POWER PLANT</b> .....	102
6.1. INTRODUCTION .....	102
6.2. EFFICIENCIES IN POWER PLANT .....	103
6.3. OPEN SYSTEM ANALYSIS .....	105

6.4. BOILER AND BOILER IN CO-GENERATION .....	106
6.5. HEAT EXCHANGER EFFICIENCY .....	110
6.6. STEAM/GAS TURBINE EFFICIENCY .....	113
6.7. POWER PLANT MONITORING AND DATA COLLECTION .....	114
6.8. QUESTIONS .....	117
REFERENCES .....	119
<b>CHAPTER 7 WIND TUNNEL .....</b>	<b>121</b>
7.1. INTRODUCTION .....	121
7.2. BERNOULLI EQUATION .....	122
7.3. PITOT-STATIC TUBE AND VELOCITY MEASUREMENT .....	123
7.4. WIND TUNNEL BASICS .....	125
7.5. WIND TUNNEL EXPERIMENT .....	127
7.6. QUESTIONS .....	134
REFERENCES .....	136
<b>CHAPTER 8 OTTO AND DIESEL CYCLES .....</b>	<b>138</b>
8.1. INTRODUCTION .....	138
8.2. OTTO AND DIESEL CYCLES .....	138
8.3. ENGINE ANALYSIS .....	146
8.4. FUELS FOR ENGINES .....	148
8.5. ENGINE TESTING .....	150
8.6. QUESTIONS .....	158
REFERENCES .....	159
<b>CHAPTER 9 REFRIGERATION .....</b>	<b>160</b>
9.1. INTRODUCTION .....	160
9.2. REFRIGERATION CYCLE .....	161
9.3. COEFFICIENT OF PERFORMANCE (COP) .....	163
9.4. REFRIGERANT .....	164
9.5. RANQUE-HILSCH VORTEX TUBE .....	166
9.6. REFRIGERATION EXPERIMENT .....	169
9.7. QUESTIONS .....	174
REFERENCES .....	176
<b>CHAPTER 10 REPORT PREPARATION .....</b>	<b>177</b>
10.1. INTRODUCTION .....	177
10.2. REPORT FORMAT AND CONTENTS .....	177
10.3. DIMENSIONS AND UNITS .....	180
10.4. SIGNIFICANT FIGURES .....	183
10.5. FIGURE AND GRAPH FORMAT .....	184
10.6. QUESTIONS .....	187
REFERENCES .....	189
<b>APPENDIX I .....</b>	<b>190</b>
<b>APPENDIX II .....</b>	<b>195</b>
<b>APPENDIX III .....</b>	<b>199</b>
<b>APPENDIX IV .....</b>	<b>202</b>
<b>APPENDIX V .....</b>	<b>207</b>
<b>APPENDIX VI .....</b>	<b>212</b>
<b>APPENDIX VII .....</b>	<b>221</b>
<b>SUBJECT INDEX .....</b>	<b>228</b>

## **PREFACE**

Thermal fluid science is an important traditional subject in engineering, which deals with thermodynamics, fluid flow, and heat transfer. Tremendous efforts have been made so far, particularly during the last couple of centuries or so, on advancing the technology and fundamental research of heat engines and fluid flow and heat transfer devices. In addition to the large number of research and review paper publications, many classic books have been published and are available in the market, primarily for standard fundamental and classroom learning with few experimental and real-world data for learning and exercise. This book contributes to this aspect of thermal fluid science and technology; it focuses on experimental and real-world operating data and relevant fundamentals. For examples, operating data in power plants regarding boilers, steam turbines, and gas turbines are provided to analyze efficiencies, along with fundamentals and use of the steam tables. Experimental data of Venturi and orifice plate flow meters are provided to show step by step how to calibrate these two important flow meters, along with experimental steps. Detailed experimental data of wind tunnels, sphere heating/cooling, pipe flow, engines, and refrigerators/heat pumps are provided to show how to test and use these important devices and how to evaluate the heat transfer coefficients and friction coefficient/factor. Figures from original patents are directly used to show readers how to prepare figures in patents. Useful data, equations, solutions, and correlations are given in the Appendix sections.

More specifically, this book volume aims to relate the thermal-fluid science fundamentals with real-world operation of important devices that greatly impact our daily lives, such as power generation, heat transfer, air conditioning, refrigeration, engines, flow meters, airplane flying, and pipe flows. In other words, the objective of this book is to provide an introduction to the essential knowledge required to perform analysis and evaluation for practical systems and several major inventions; the book also presents and discusses the experimental methods and apparatus. In addition to providing an introduction in Chapter 1, major concerns in the thermal fluid laboratory, such as safety and training, are summarized. The book outlines the basic methods for data statistics and error analysis in Chapter 2, along with an experiment method and data for exercise. Chapter 3 of the book presents the fundamentals

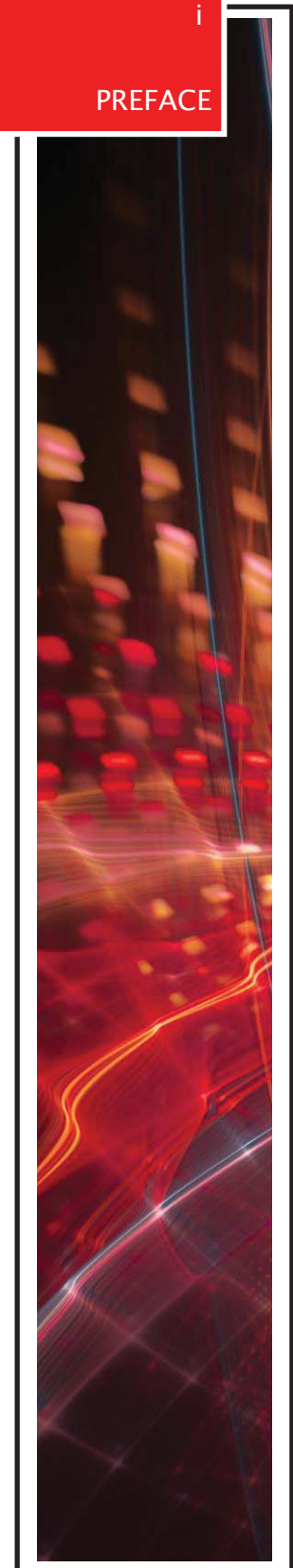



of heat transfer, measurement of temperature and heat transfer coefficient, and an example of sphere cooling/heat experiment. Following the format of Chapter 3, Chapters 4-9 describe and discuss power plant operation, pipe flow, and flow meters, power plant efficiencies, wind tunnel, engines, and refrigeration. Chapter 10 focuses on the report preparation and basics of dimensions, units, and significant figures, along with the requirement for figures and graphs.

This book is based on my about 15 years of teaching experience at the UC Irvine MAE107 Thermal Fluid Science Laboratory. I would like to thank Daniel Kahl, Bongjin Seo, Qin Chen, Jingtian Wu, Patrick Hong, Frederick R. Bockmiller, and Daniela Fernanda Ruiz Diaz at the UC Irvine for their assistance in the book preparation.

#### **CONSENT FOR PUBLICATION**

Not applicable.

#### **CONFLICT OF INTEREST**

The author declares no conflict of interest, financial or otherwise.

#### **ACKNOWLEDGEMENTS**

Declared none.

**Yun Wang**

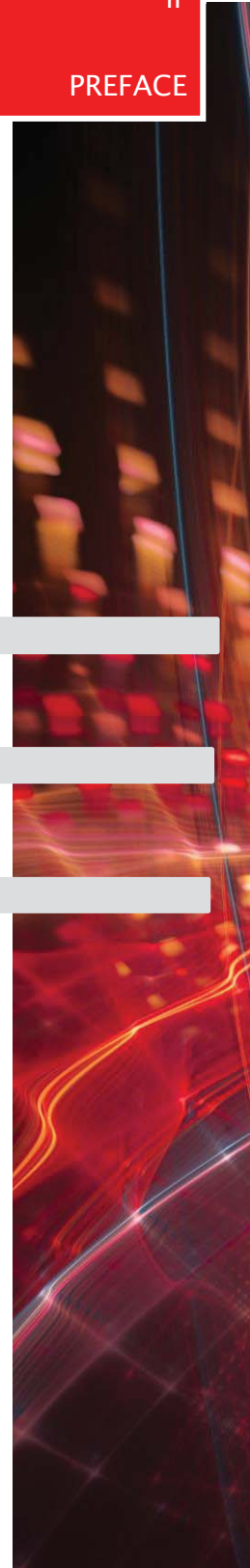

## SYMBOLS

$A$ :	Area [ $\text{m}^2$ ]; Surface
$A_s$ :	Surface area [ $\text{m}^2$ ]
$c$ :	Standard deviation of the wind speed [ $\text{m/s}$ ]; Specific heat per mass [ $\text{J/K kg}$ ]
$C$ :	Specific heat [ $\text{J/K}$ ] or [ $\text{J/K kg}$ ]
$C_D$ :	Drag coefficient [-]
$C_o$ :	Orifice coefficient [-]
$C_v$ :	Specific heat at constant volume [ $\text{J/K}$ ] or [ $\text{J/K kg}$ ]; Venturi coefficient [-]
$C_p$ :	Specific heat at constant pressure [ $\text{J/K}$ ] or [ $\text{J/K kg}$ ]
$D$ :	Diameter [ $\text{m}$ ]; Cross section diameter [ $\text{m}$ ]
$e$ :	Internal energy [ $\text{J}$ ]; potential [ $\text{V}$ ]
$E$ :	Radiation heat flux [ $\text{J/m}^2/\text{s}$ ]; Total Energy [ $\text{J}$ ] or [ $\text{BTU}$ ]
$f$ :	Fanning friction factor [-]
$F$ :	Force [ $\text{N}$ ]
$h$ :	Height [ $\text{m}$ ]; Heat transfer coefficient [ $\text{W}/(\text{m}^2\cdot\text{K})$ ]; Specific enthalpy [ $\text{J/kg}$ ]
$h_{vl}$ :	Latent heat of water condensation [ $\text{J/kg}$ ] or [ $\text{BTU}/\text{scf}$ ]
$\Delta H$ :	Liquid height [ $\text{m}$ ]
$k$ :	Mean wind speed [ $\text{m/s}$ ]; Ratio of specific heats [-]; Thermal conductivity [ $\text{W}/(\text{m}\cdot\text{K})$ ]
$K$ :	Calibration constant [ $\text{K/V}$ ] or [ $^\circ\text{C/V}$ ]
$L_w$ :	Length [ $\text{m}$ ]
$m$ :	Mass [ $\text{kg}$ ]
$p$ :	Pressure [ $\text{N}/\text{m}^2$ ]
$P$ :	Pressure [ $\text{N}/\text{m}^2$ ]; Probability [-]
$q$ :	Heat flux [ $\text{J}/\text{m}^2/\text{s}$ ]
$\dot{q}$ :	Energy [ $\text{J}$ ] or [ $\text{BTU}$ ]
$q''$ :	Heat flux [ $\text{J}/\text{m}^2/\text{s}$ ]
$Q$ :	Surface heat flow rate [ $\text{W}$ ]
$\Delta Q$ :	Heat added to the system [ $\text{J}$ ]
$\dot{Q}$ :	Volume flow rate [ $\text{m}^3/\text{s}$ ]
$r$ :	Compression ratio [-]; Radial dimension
$R$ :	Radius [ $\text{m}$ ]
$Re$ :	Reynolds number [-]

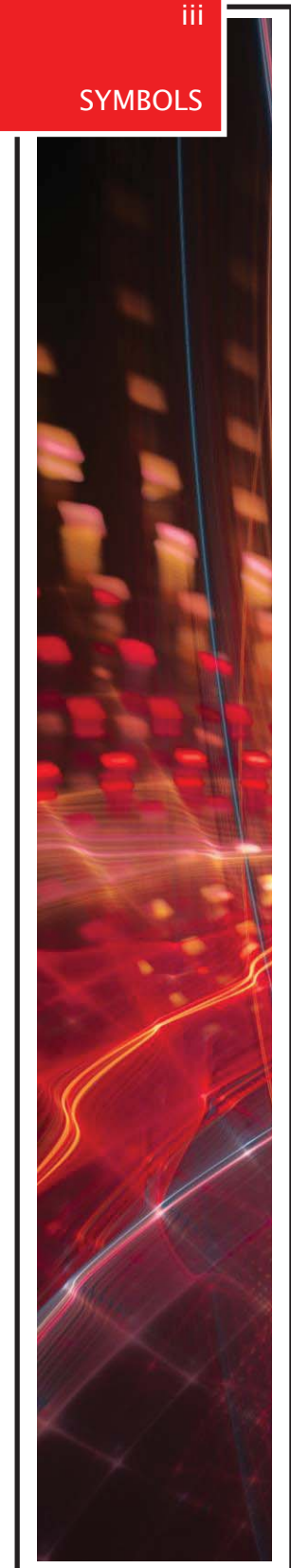

$R_T$ :	Resistivity [K/W]
$s$ :	Entropy [J/K]
$t$ :	Time [s]
$T$ :	Temperature [K] or [°C]
$T_\infty$ :	Ambient temperature [K]
$T_s$ :	Surface temperature [K]
$T_{surr}$ :	Surrounding temperature [K] or [°C]
$u$ :	Velocity [m/s]
$\bar{u}$ :	Average velocity [m/s]
$U$ :	Velocity [m/s]
$\bar{U}$ :	Mean velocity [m/s]
$v$ :	Specific Volume [m <sup>3</sup> /kg]
$V$ :	Volume [m <sup>3</sup> ]
$\dot{V}$ :	Volume flow rate [m <sup>3</sup> /s]
$w$ :	Work [J] or [J/kg]
$W$ :	Work [J]
$\Delta W$ :	Work done to the surroundings [J]
$\dot{W}$ :	Work flow rate [W]



## GREEK

- $\alpha$ : Thermal diffusivity [ $\text{m}^2/\text{s}$ ]
- $\beta$ : Ratio of diameter [-]
- $\epsilon$ : Roughness factor [-]; Emissivity [-]
- $\Theta$ : Dimensionless temperature [-]
- $\eta$ : Thermal efficiency [-]
- $\mu$ : Dynamic viscosity [ $\text{Pa}\cdot\text{s}$ ]
- $\rho$ : Density [ $\text{kg}/\text{m}^3$ ]
- $\sigma$ : Stress tensor [ $\text{N}/\text{m}^2$ ]; Boltzmann constant [ $5.6703 \times 10^{-8} \text{ W}/\text{m}^2/\text{K}^4$ ]
- $\tau$ : Time constant [-]
- $\tau_w$ : Viscous shear stress [ $\text{N}/\text{m}^2$ ]
- $\nu$ : Kinematic viscosity [ $\text{m}^2/\text{s}$ ]



# INTRODUCTION

## 1.1. INTRODUCTION TO THERMODYNAMICS, FLUID FLOW, AND HEAT TRANSFER

Thermodynamics, fluid flow, and heat transfer not only play an important role in science and engineering but also in everyday life. For example, gasoline vehicles operate on the Otto cycle, residential air-conditioners are developed based on the vapor-compression refrigeration cycle, steam turbines are the central unit in traditional power plants, and flow meters and pipe flows are inherent in both industrial and residential applications.

Thermodynamics can be defined as the science of energy, which deals with heat and temperature and their relationship with energy, work, and properties of matter. The knowledge about thermodynamics behaviors comes from observations, which are then formulated into laws, including the well-known first and second laws of thermodynamics [1]. Heat, work, entropy, various types of energy, efficiency, pressure, force, and temperature are the major metrics used when studying thermodynamics.

Heat transfer relates to the generation, use, conversion, and exchange of heat or thermal energy. Heat is transferred by three main modes, including heat conduction, convection, and radiation. In addition, phase change involves latent heat release or absorption. In general, thermodynamics describes equilibrium states, *i.e.* state properties such as temperature, pressure, and internal energy are the same in all the spatial dimensions of a system. Heat transfer, in contrast, depicts non-equilibrium phenomena such as temperature gradients. The popular heat transfer properties include thermal conductivity, heat transfer coefficient, thermal diffusivity, and emissivity. Temperature gradients and evolution and heat flux/rates are the major metrics used when studying heat transfer.

Fluid mechanics describes the flow of fluids, such as liquid, gas, and plasma. It describes basic concepts and governing equations underlying fluid behaviors, including the conservation principles of mass and momentum. Viscosity is an important concept relating to viscous flows. Shockwaves occur when the Mach number reaches 1 or the fluid velocity approaches the sound speed. Turbulent flows are frequently encountered in nature and industrial applications. The distributions and evolutions of fluid velocity, density, and

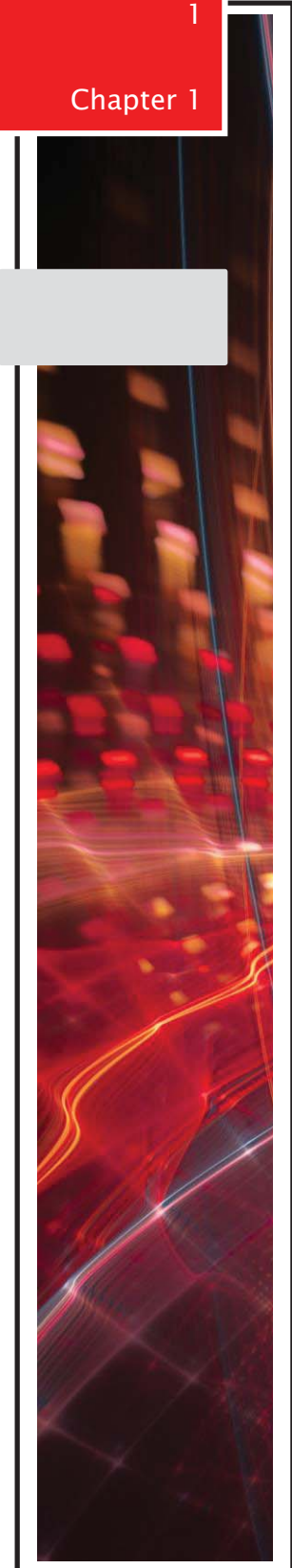

pressure, and flow rate are the major metrics used when studying fluid mechanics. Table 1.1 summarizes the major equations and laws in the three subjects.

**Table 1.1 Typical equations in thermodynamics, heat transfer, and fluid mechanics [2, 3].**

Thermodynamics	1 <sup>st</sup> Law: $\Delta E = Q - W$ 2 <sup>nd</sup> Law: $ds \geq \frac{\delta Q}{T}$
Heat Transfer	$\rho \left[ \frac{\partial e}{\partial t} + \mathbf{u} \cdot \nabla e \right] = \nabla \cdot (k \nabla T) + \mu \Phi + \dot{q}$ Continuity equation: $\frac{\partial \rho}{\partial t} + \nabla \cdot (\rho \mathbf{u}) = 0$
Fluid Mechanics	Momentum Equation: $\rho \left[ \frac{\partial \mathbf{u}}{\partial t} + \mathbf{u} \cdot \nabla \mathbf{u} \right] = -\nabla p + \nabla \cdot [\mu (\nabla \mathbf{u} + (\nabla \mathbf{u})^T)] + \rho \mathbf{g}$



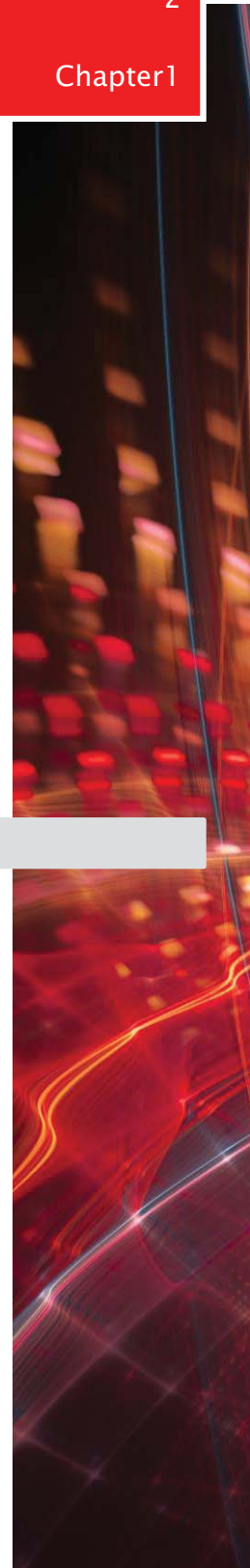

## 1.2. EXPERIMENTAL MEASUREMENT

Measurement is frequently encountered in daily activities. For example, rulers and body thermometers are used to measure a person's height and body temperature. Gas stations need to quantify how many gallons or liters of gasoline are added to a fuel tank. Experimental measurement is not merely reading a number and obtaining a value. The selection of measurement equipment/apparatus, techniques, and methods to meet any accuracy requirements is an important task for any experimental work. In practice, direct measurement is not always the final target. For example, in a liquid-in-glass thermometer, the temperature is not directly measured. Instead, the liquid length is measured by a ruler, which is then converted to temperature through their correlation. In a thermocouple, the voltage difference between the two junctions is directly measured by a voltage meter, which is then converted to temperature through their relationship. Any errors in the direct measurement of length or voltage using a ruler or voltage meter will eventually pass to the final temperature measurement. Thus, understanding error propagation from direct measurement to the final value, *i.e.*, error or uncertainty analysis, is important for experimental design, equipment selection, and method development.

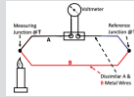

In thermal-fluid experiments, metrics such as time, mass, volume, length, velocity, flow rate, voltage, temperature, pressure, and current are frequently used. Various types of equipment have been developed to measure these quantities. Each of them has a specific range of applications with corresponding precision and full range. In general, a high-precision measuring instrument is costly, and budget plays an important role in equipment selection and project design, especially in industrial development. For example, a school ruler of 1 mm in precision, which suffices for K-12 work, costs about one dollar. A micrometer caliper of 0.001 mm precision, widely used in engineering and scientific work, costs about 10-100 dollars. Table 1.2 lists a few examples of equipment for temperature, pressure, velocity, or flow rate measurement.

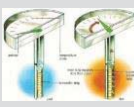
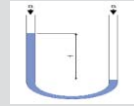
**Table 1.2. Equipment for the thermal-fluid experiment.**

Quantity	Instrument	Information	Image
Temperature	Thermocouples	Measure the temperature-dependent voltage based on the thermoelectric effect.	
	Liquid-in-glass Thermometers	Use liquid thermal expansion.	
	Infrared sensors	Measure the radiation.	
	Bimetallic devices	Use a bimetallic strip to convert temperature to mechanical displacement.	
Pressure	Liquid column elements	Use hydrostatics.	
	Elastic element gauge	Use elastic measuring elements.	
	Electrical transducers	Measure the deformation of elastic material under pressure and convert it to pressure.	



# ANALYSIS OF EXPERIMENTAL DATA

## 2.1. INTRODUCTION

In an experiment, one major task is to conduct measurements for collecting data. A large number of measurement data can be the direct outcome of experimental work. In general, the more data the better. Statistics is a popular valuable tool for experimentalists to conduct data analysis and eventually draw conclusions from data processing. The mean of a data sample is usually used as the final result for a measurement. The standard deviation of the sample measures the confidence of the final result and is usually used as additional information. In addition, each measurement needs to be independent so that the data set is equally weighed. Statistics may be used in experimental design and plan. Indeed, before conducting an experiment, several aspects need to be considered in preparation, including the selection of apparatus, relevant mathematical correlations, and uncertainty estimate of the final results. Selecting the proper apparatus is essential to any experimental work. For example, temperature measurement requires thermometers. There are several types of thermometers with various ranges and resolutions. A high-resolution apparatus is usually expensive and requires training before use. However, low-resolution apparatuses usually lead to a large standard deviation or uncertainty in the final result. In engineering applications, uncertainty needs to be within tolerance to avoid component mismatch or design failures. Understanding how the apparatus' resolution is related to the measurement error or uncertainty and how the error or uncertainty propagates to the final value is thus fundamentally important for experimental design, which will be introduced in this chapter.

## 2.2. ERROR AND UNCERTAINTY ANALYSIS

Prior to the experiment, it is important to estimate the effect of measurement errors in final results. For example, there is an error or uncertainty in the measurement of time using a stopwatch. Then, using this stopwatch in the speed measurement of a car in a freeway, the error or uncertainty in the time measurement will then influence the final result of the car speed. This is practically important for issuing speed tickets on the road. To evaluate the error or uncertainty in a final result, one needs to:

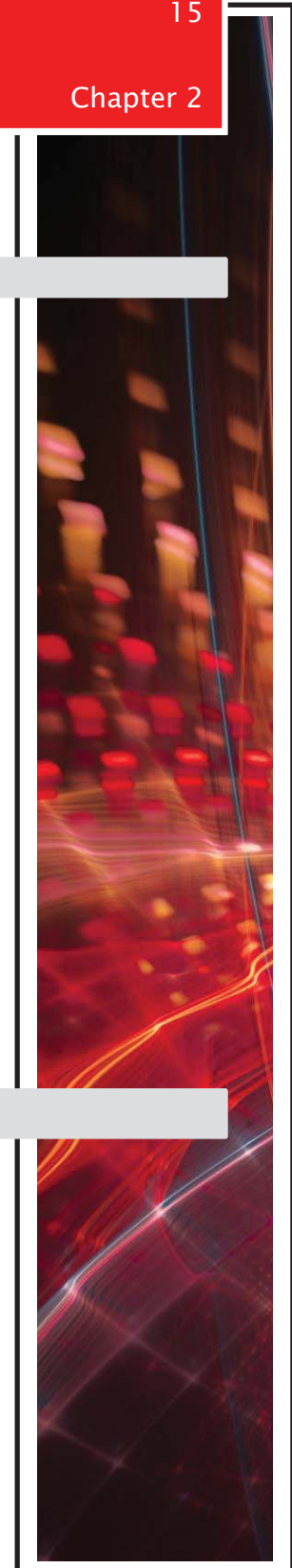



- (1) describe the relationship between the final result and a measured quantity, and
- (2) estimate the error or uncertainty in the measurement of the quantity.

A simple example is the temperature measurement from a thermocouple, in which temperature is the final result or target and the voltage is the measured quantity. In other words, we directly measure the voltage in a thermocouple and then use a formula to convert the voltage to temperature. Assuming the relationship between temperature and voltage is linear with a calibration constant  $K$ :

$$T = Ke \quad \longrightarrow \quad 1$$

The voltage error,  $\delta e$ , in the measurement will then lead to an error in the final temperature:

$$\delta T = K\delta e \quad \longrightarrow \quad 2$$

Since the calibration equation is linear, the temperature error is independent of the magnitude temperature itself. For this reason, linear sensors are often desirable. Another example is the pressure transducer, which converts the voltage signal to pressure using a linear relationship.

In contrast to thermocouples, the flow rate measurement using the data of volume and time measurement is non-linear, involving multiple variables, *i.e.* the flow rate  $\dot{Q}$  is the volume  $V$  divided by the elapsed time  $t$  that the flow rate takes to fill the volume  $V$ , as below:

$$\dot{Q} = \frac{V}{t} \quad \longrightarrow \quad 3$$

Mathematically, the error in  $\dot{Q}$ , *i.e.*  $\delta \dot{Q}$ , is obtained by applying the chain rule of differentiation to Equation 3:

$$\delta \dot{Q} = \frac{1}{t} \delta V - \frac{V}{t^2} \delta t \quad \longrightarrow \quad 4$$

where  $\delta V$  and  $\delta t$  are errors in the volume and time measurements, respectively. In general, errors fall into two categories:



### Bias and Uncertainty.

Bias is an average difference between the measurement from a device and that from an accepted standard. For example, a watch might be biased by two minutes ahead of the accurate time from an accepted reference such as the atomic clock at the US Naval Observatory. On a weight scale, you need to reset it in order to have an accurate evaluation of your body weight. Uncertainty is the error due to reading the measurement (*e.g.* estimate below the smallest scale division) and/or fluctuations inherent in an equipment (*e.g.* noises). For noises, a digital weight scale may give a fluctuating number in the display, which may be due to the noise from the pressure sensor or voltage reading. Note that the body weight fluctuation from morning to night may be treated as a ‘noise’ in your body, as it is not associated with the scale. In general, uncertainty is precision plus noises and accuracy is bias plus uncertainty. Note that a measurement can have high precision but low accuracy; high accuracy does require high precision. We exclude gross errors or blunders, such as reading the wrong scale or transcribing the data and omitting a factor of 10, wrong units, *etc.*

To show the mathematical relationship, the error in a variable X, *i.e.*  $\delta X$ , is the sum of the bias and random parts:

$$\delta X = \epsilon_X + \delta x \quad \longrightarrow \quad 5$$

where  $\epsilon_X$  is the bias and  $\delta x$  is the uncertainty or random part such that  $\|\delta x\| = 0$ . The former is an average over many readings or the time average of a fluctuating reading. In the following discussion, the biases are neglected and assumed to be zero after calibration. As to uncertainty, we assume it arises from estimate below the smallest scale division only. Under usual conditions, our human eyes can fairly well estimate whether a reading is above or below the middle of the smallest scale division. Conventionally, the uncertainty is set to be:

#### Half of the Smallest Scale Division or Precision.

Note that in practice, the measurement uncertainty is dependent on experience.



# HEAT TRANSFER

## 3.1. INTRODUCTION

Heat transfer is a subject that deals with the generation, use, conversion, and exchange of thermal energy between a system and its surroundings. At the molecular level, we can visualize thermal energy by the motion of particles and quantify it by the overall kinetic energy of all the particles. Heat transfer can then be explained as an exchange of the kinetic energy among particles *via* collisions or interactions. In a gas, the particles move faster, on average, under higher temperatures and transfer their kinetic energy to particles at lower temperatures through collisions. In a solid, the particles vibrate faster under higher temperatures and transfer their kinetic energy to particles at lower temperatures through molecular interactions.

We observe heat transfer in our everyday activities and many engineering developments. For example, the thermal energy released from burning natural gas in a burner on a kitchen stove heats a pan through convection, which is further conductively transferred to the food in the pan. In another example, on a hot summer day fans move air for body cooling via forced convective heat transfer: a higher air flow rate provides more cooling. The fan speed and power are well designed in factories to meet the cooling demand of our human body. In engine-driven vehicles, coolant circulates through internal combustion engines (ICE) for heat removal by forced convection. The coolant increases its temperature and delivers the heat to a radiator, where the heat is rejected to the ambient by both radiation and convection modes. Automakers design these systems to meet engine requirements, such as maximum temperature tolerance and heat removal rate while optimizing material costs and weight to meet vehicle-designed price points and fuel efficiency standards.

Inadequate heat removal causes material damage, device malfunction, and operational failures. For example, on February 1, 2003, the Space Shuttle Columbia disaster, a fatal incident in the United States space program that occurred when the Space Shuttle Columbia (OV-102) disintegrated as it reentered the atmosphere, was caused by the damage of a piece of foam insulation from the Space Shuttle external tank. During reentry, hot atmospheric gases penetrated the thermal shield and burned the internal wing structure [1]. In 2011, the disaster of the Fukushima Daiichi nuclear power plant in Japan was caused by an earthquake and tsunami, which shut down the electric power for cooling the reactor and removing the decay heat. The reactor



cores of units 1-3 overheated, which melted the nuclear fuel and caused leakage of contaminants and radioactive materials to the ambient. In an automobile ICE, leakage, low volume of coolant, or pump failure will reduce engine heat removal, causing high engine temperature and failure.

### 3.2. TEMPERATURE MEASUREMENT

Temperature is an important quantity widely used in our everyday activities. A body thermometer is used for fever diagnosis. The water of a lake or river freezes in a cold winter where the ambient temperature drops below  $0\text{ }^{\circ}\text{C}$ . Water boils at  $100\text{ }^{\circ}\text{C}$ , under one standard atmosphere (enough to raise a column of mercury 760 mm or pressure of 101,325 Pa). Hereinafter, we will refer to this pressure by the abbreviation 1 atm.

In thermodynamics, the temperature is a state property to evaluate the phase of a substance, internal energy, enthalpy, and heat transfer. In a Carnot cycle, thermal efficiency is directly expressed as a function of the high and low temperatures of the two associated reservoirs. The ideal gas law can be extrapolated to zero pressure, under which temperature drops to the absolute zero degrees (0 K or approximately  $-273.15\text{ }^{\circ}\text{C}$ ). In many industrial processes, the temperature is monitored to ensure the proper functions of devices and reactions. For example, state-of-the-art PEM fuel cells work under about  $80\text{ }^{\circ}\text{C}$  to produce power at high efficiency [2]. Too high or low temperature will reduce fuel cell performance and efficiency. In practice, thermocouples are equipped in a fuel cell system to monitor its thermal 'health' and ensure optimal operation [3].

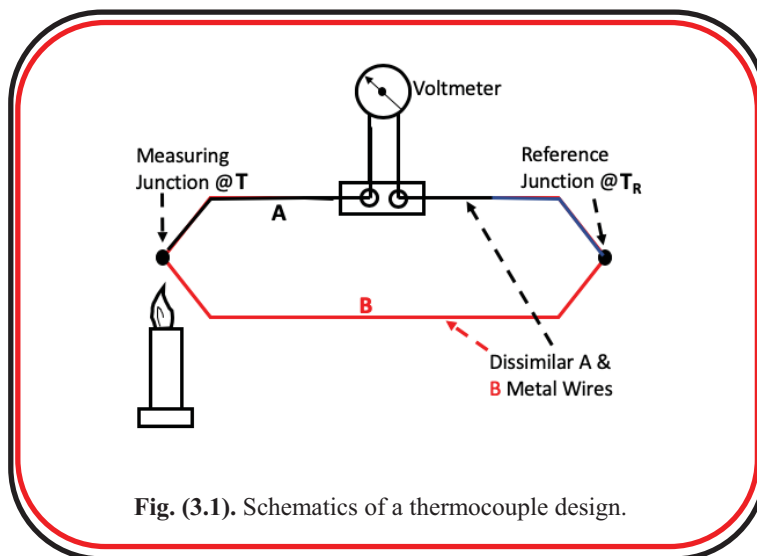
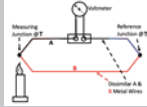

Fig. (3.1). Schematics of a thermocouple design.

Various types of thermometers are available commercially for temperature measurement. Mechanical thermometers, which use inherent characteristics of a material against a calibrated scale, are the first and primary thermometers. Liquid-in-tube thermometers are based on the principle of thermal expansion and measure the expanded volume of liquid in a narrow tube, which is then calibrated to temperature. Originally air was used, later alcohol, and then mercury, which expands less than alcohol, became the most common. With growing awareness of its toxicity, mercury thermometers began to be replaced with other types of liquid. Bimetallic thermometers are another popular type. They work by the differential expansion of two metals, commonly steel and copper, which causes the actuator to bend. This bending or twisting is then used to move a needle adjacent to a scale. Rugged and dependable, these thermometers are popular in industrial settings.

Electrically powered thermometers come in many types and are popular in the industrial, laboratory, and home settings. Resistance thermometers [4], also called resistance temperature detectors (RTD), are based on the temperature dependence of the material's electric resistance. A common RTD element structure consists of a fine wire wrapped around a ceramic or glass core. Platinum, nickel, and copper are popular wire materials. The voltage and current signals are directly measured to calculate the electric resistance, which is then calibrated to temperature. Because of the direct measurement of voltage and current signals, temperature output can be readily shown in the form of digital numbers, making it widely used in modern society. Their operation requires a power source and may be affected by its circuit resistance. Thermocouples are based on the thermoelectric Seebeck effect [5]: the temperature dependence of electric potential. A thermocouple measures the electric voltage between two junctions of dissimilar materials, which is converted to the temperature difference with a reference point  $T_R$ , as shown in Fig. (3.1). Because of direct voltage measurement, its operation is independent of the connecting wire length, interfacial resistance, and a power source, making it widely adopted in scientific and engineering studies. Table 3.1 lists popular types of thermometers.

**Table 3.1. Equipment for the thermal-fluid experiment.**

Types	Function	Image
Thermocouple	Measure a temperature-dependent voltage as a result of the thermoelectric effect, which is interpreted to temperature	



# POWER PLANT

## 4.1. INTRODUCTION

Power plants or generating stations are facilities for generating electric power, which has become essential to our present lifestyle. Electric power supports many of our daily activities, including lighting, air circulation, HVAC, TV watching, cell phones, computers, elevators, *etc.* The generated power is delivered using complex systems of wires, towers, underground stations, transformers, control stations, *etc.*, to consumer sites such as homes, apartments, stores, industry, and schools. These interconnected systems are known as grids.

For the past 150 years, most power plants have used fossil fuels, such as coal, petroleum, and natural gas, to generate electricity. Heat engines convert thermal energy from fuel combustion to rotating kinetic energy to turn generators and produce electric power. Owing to their high efficiency, continuous smooth motion, durability, low maintenance cost, and the possibility of production in enormous size, steam turbines remain the most popular heat engines in traditional central-station large power plants.

In operation, boilers burn fossil fuels and produce high-temperature, high-pressure steam. The steam passes through a steam turbine for energy conversion and condenses at the condenser side. The liquid condensate is then pumped back to the boilers for steam production. Various designs have been developed to improve the steam turbine and overall conversion of thermal energy to electric power generation, including the combined-cycle configuration [1, 2].

In recent years, clean and renewable power generation methods, including nuclear, solar photovoltaic, solar thermal, geothermal, biomass, waste-to-energy, and wind, have received growing attention. Steam turbines are a major part of nuclear, geothermal, biomass, waste-to-energy, and solar thermal power plants. These clean energy sources produce high-pressure steam, driving steam turbines for energy conversion. Some renewable and clean electric power plants, such as solar panels, wind turbines, hydropower, and fuel cells, do not rely on heat engines for energy conversion.



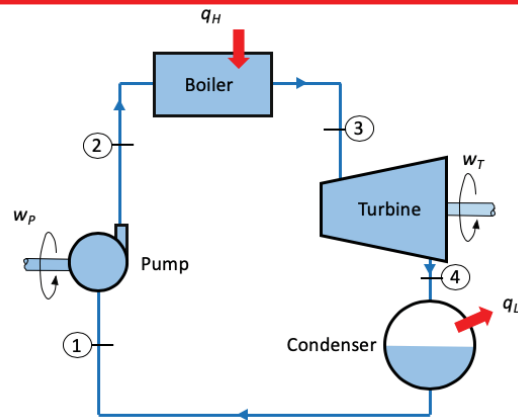

Fig. (4.1). Steam turbine and ideal Rankine cycle.

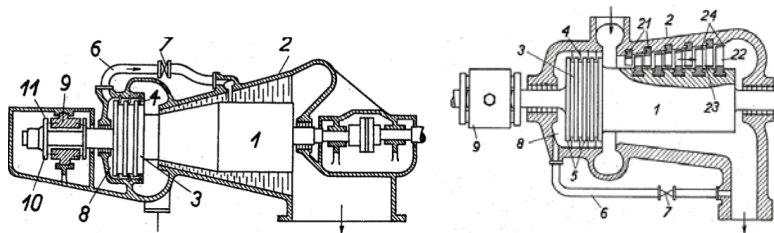

Fig. (4.2). Steam turbine design in a patent: 1 is the rotor and 2 is the casing of the turbine. 3 is a dummy piston for balancing the axial thrust acting on the blading of the shaft and 4 are the packing on the dummy piston [3]. Steam flows through the sealing gap between the packing members 4 and collars 5 on the shaft and pipe 6 to a lower stage of the turbine or condenser.

## 4.2. STEAM TURBINE POWER GENERATION

A steam turbine is a heat engine that extracts thermal energy from steam and transforms it into the mechanical work of a rotating shaft, which (in electric power generation) drives a generator to produce electricity. Steam turbine operation can be described by the Rankine Cycle, as shown in Fig. (4.1), with 4 processes and water/steam as its working fluid:

- Process 1-2: Isentropic compression in a pump. Water condensate is pumped from a state of low-pressure liquid to a high-pressure state.
- Process 2-3: Constant pressure heat addition in a boiler. High-pressure water enters a boiler, where heat is added by fuel combustion, nuclear reaction, or other sources, to vaporize the water under constant pressure. In water-tube boilers, the vapor in the drum is saturated as long as there is liquid water. The addition of heat to the steam beyond the drum will

- increase its temperature, which is called superheating. Note that nuclear power plants do not generally superheat steam.
- Process 3-4: Isentropic expansion in a turbine. Superheated steam goes through multi-stage expansion in a steam turbine, which produces the mechanical work of shaft rotation. The steam pressure and temperature drop during this process.
- Process 4-1: Heat rejection under constant pressure in a condenser. Steam enters a condenser, where it condenses under constant pressure to become condensate, back to the initial state of the cycle.

Table 4.1 lists the Rankine cycle processes and major equations. Fig. (4.2) shows a steam turbine design proposed in a patent. The thermodynamic processes of the ideal Rankine cycle are shown by the T-s diagram in Fig. (4.3) (left). In power generation, the rotating shaft connects with an electric generator in the process 3-4.

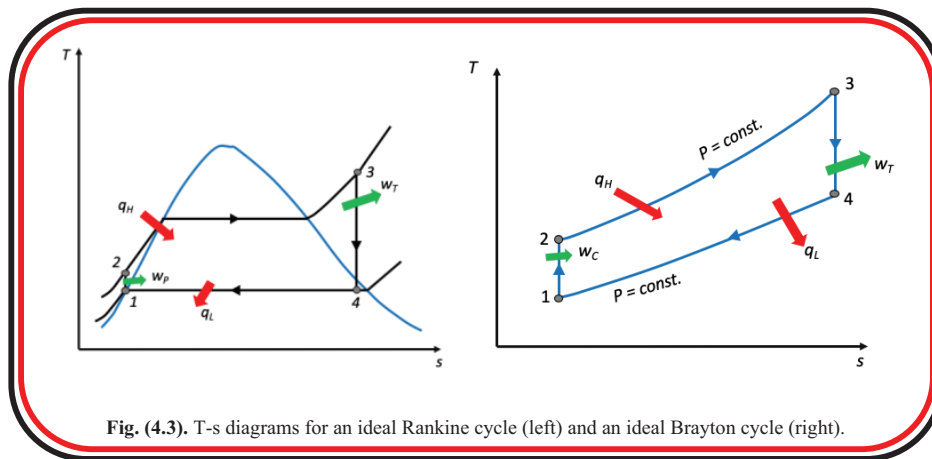

Fig. (4.3). T-s diagrams for an ideal Rankine cycle (left) and an ideal Brayton cycle (right).

Table 4.1. The Rankine cycle processes.

Component	Energy Eq.	Entropy Eq.	Process
Pump	$0 = h_1 + w_p - h_2$	$0 = s_1 - s_2 + (0/T) + 0$	$q = 0, s_1 = s_2$
Boiler	$0 = h_2 + h_3 - q_H$	$0 = s_2 - s_3 + \int \frac{dq}{T} + 0$	$P_3 = P_2 = C$



## **PIPE FLOW AND FLOW METERING**

### **5.1. INTRODUCTION**

Flow and volume measurement of incompressible fluids are prevalent in many engineering processes. Flows in a pipe network, also called pipe flow, are widely encountered in industry and our daily activities. For example, water is delivered to homes via the pipelines of a water distribution infrastructure. In power plants, numerous pipe flows are used to transport liquid, vapor, and two-phase flows: steam produced in boilers is transported in pipes to steam turbines for energy conversion. Boiler feed water (BFW) is pumped to a boiler via a BFW pipe.

In pipe system design, the main questions to be addressed are usually (1) what is the pipe diameter for a given flow rate, system length, and available pressure drop (2) for a given pipe and required flow rate, what is the pressure drop, and (3) what the optimum cost-effective design between pipe size and pumping energy use is. The flow rate and pressure drop determine the pumping power requirement, which is a major economic concern in system operations. Laminar flow in a straight section of a pipe or tube provides a classic example of the application of fluid mechanics equations to a practical problem.

Flow and volume meters are used in scientific work, industry, central energy plant operations, and infrastructure systems to quantify and measure flow rates for design, monitoring, or control purposes. Utilities use volume meters for revenue, such as the natural gas meter and the water meter serving your residence.

There are various types of flow rate and volume totalizing meter designs, with each usually having a specific accuracy, cost, and reliability. Among them, orifice plate and venturi meters remain common flow rate meters and measure pressure drop for the flow rate. Their operating principles are based on the basic fundamentals of fluid dynamics.

### **5.2. PRESSURE MEASUREMENT**

Pressure is defined as a force over a unit of area. In fluids, several concepts are frequently used in pressure measurement, including absolute pressure, gauge pressure, and vacuum. The first is referred to as the absolute value of a force on a unit area of a wall that a fluid exerts. The second is the absolute pressure minus the local ambient (typically atmospheric) pressure. The third is that

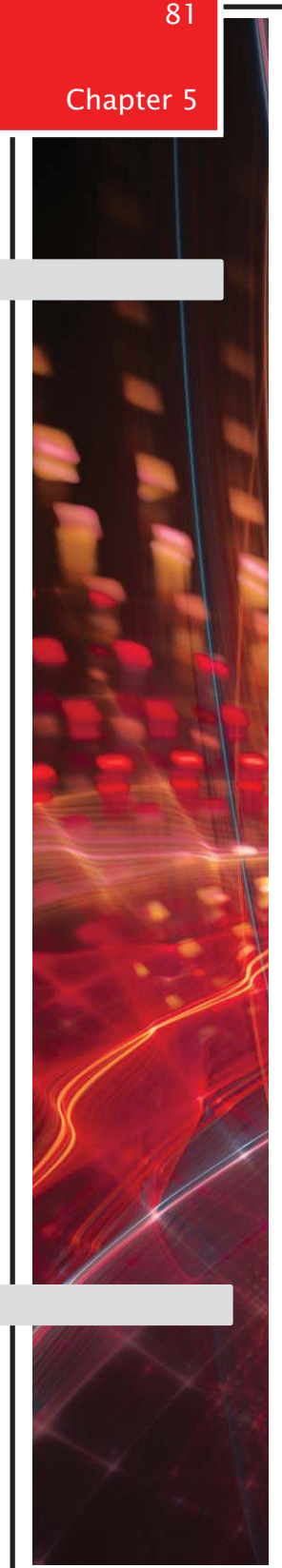

pressure less than the local ambient. It can be described as the ambient minus the absolute, provided that the absolute does not exceed the ambient. In measurement, manometers are widely used, which measure liquid height and convert it to pressure using the hydraulic pressure imposed by the liquid height. A simple design is the U-tube manometers, in which the pressure difference between the two connected tubes is given by:

$$P = \rho gh \quad \longrightarrow \quad 1$$

where  $h$  is the difference of the liquid heights in the two tubes. An example of U-tube manometer is shown in Fig. (S5.5) [1].

A barometer is a device used to measure the local atmospheric pressure. A simple barometer follows the same principle as the U-tube manometer with mercury as the working fluid. Because the saturated vapor pressure of mercury is much lower than the ambient pressure under normal conditions, the vertical height of the mercury directly approximates the air pressure. Mercury’s density is 13.6 kg/l, which leads to a 0.76 m liquid height under standard conditions. The Bourdon-tube pressure gauge is another widely used device, with an example shown in Fig. (5.1). It is based on the principle that a flattened tube tends to straighten or regain its circular form in the cross-section when pressurized. The elastic deformation causes displacement and transforms it to angular rotation of a pointer, indicating the pressure. Digital pressure transducers, often called pressure transmitters, convert pressure to analog electrical signals. They are widely used in scientific work for rapid high-accuracy measurement. Table 5.1 lists several major types of pressure measurement devices.

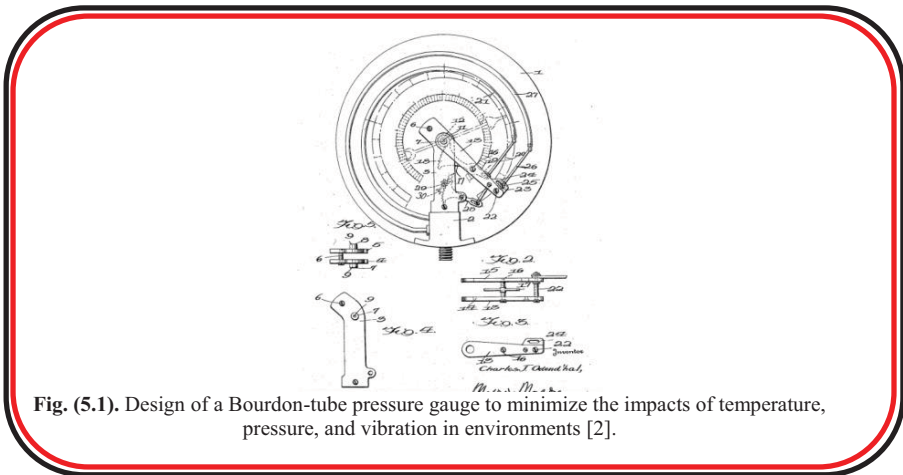

Fig. (5.1). Design of a Bourdon-tube pressure gauge to minimize the impacts of temperature, pressure, and vibration in environments [2].

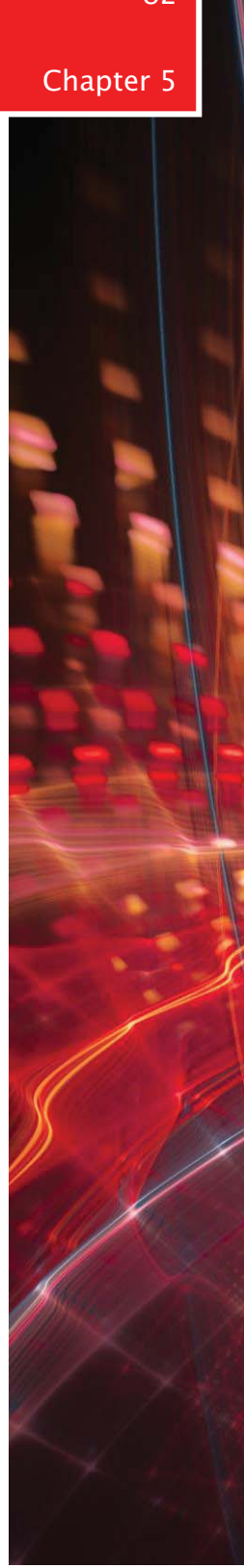

Table 5.1. Types of pressure measurement instruments.





Types	Function	Image
<b>Liquid Column Manometers</b>	It consists of a column of liquid in a tube with the difference in liquid levels representing the pressure difference. It is widely used in ventilation, air conditioning, heating, dust elimination, etc.	
<b>Bourdon-tube Pressure Gauge</b>	It is based on the principle that a flattened tube tends to straighten or regain its circular form in the cross-section when pressurized. It measures gauge pressure and is widely used in aerospace, automotive, heating, etc.	
<b>Digital Pressure Transducers</b>	It uses an electrical circuit to convert the motion produced by a mechanical pressure element to electrical signals, which are measured to indicate pressure.	
<b>Mechanical Displacement Type</b>	It converts the pressure into mechanical displacement. Two common types are ring-balance and bell-type manometers.	

Table 5.2. Types of flow meters.

Types	Function	Image
<b>Differential Pressure Flow Meter</b>	Based on Bernoulli's equation and measure the pressure drop over an obstruction inserted in a flow. Widely used in industry.	
<b>Positive Displacement Flow Meter</b>	Use precision-fitted rotors as measurement elements. Known and fixed volumes are displaced between the rotors. The rotor rotation is proportional to the fluid volume being displaced. Work best with clean, non-corrosive/erosive liquids and gases.	

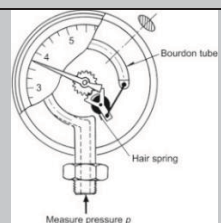

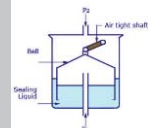
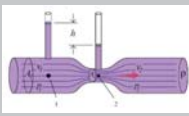
## EFFICIENCIES IN POWER PLANT

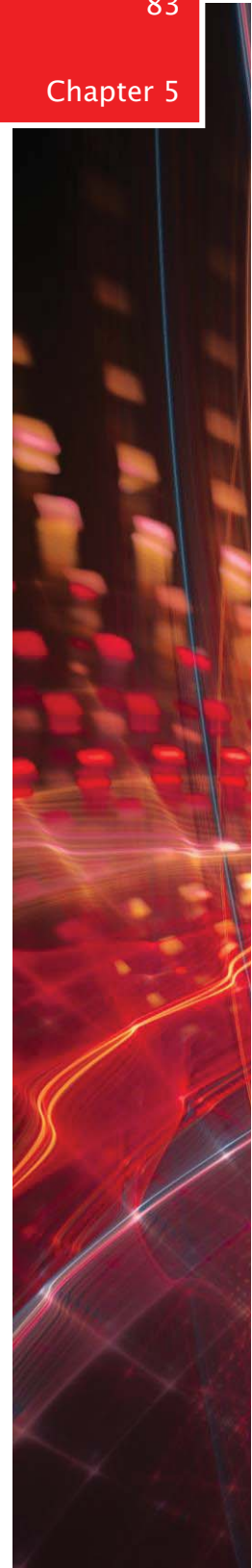
### 6.1. INTRODUCTION

In thermodynamics, several major devices related to energy conversion are introduced, including the internal combustion engines (ICE), steam turbine, boiler, heat exchanger, and heat pump. Thermal efficiency is a dimensionless performance measure of these devices. In general, thermal efficiency is the fraction of energy addition in the form of heat or thermal energy converted to useful output, as shown in Fig. (6.1), given as a percentage value. The nominally Otto-cycle ICE in automobiles can reach about 30% efficiency at the flywheel. Rankine-cycle steam turbine thermal efficiency can be as high as 41%. In heat pump cycles where heat rejection in the high-temperature side is the useful output, the efficiency is usually defined as the ratio of the rejected heat to the compressor work input, commonly called the coefficient of performance (COP). Refrigeration moves heat from a confined space and dissipates it in the atmosphere. Heat pumps move heat from one spot (often from the atmosphere or underground) to a home of business. Residential refrigerators and air conditioners are based on a vapor-compression mechanical refrigeration cycle. The former generally has a COP over 1 in practice, while the latter may have a COP over 3 to 5. The COP of heat pumps is generally higher than that of their refrigerator counterparts.

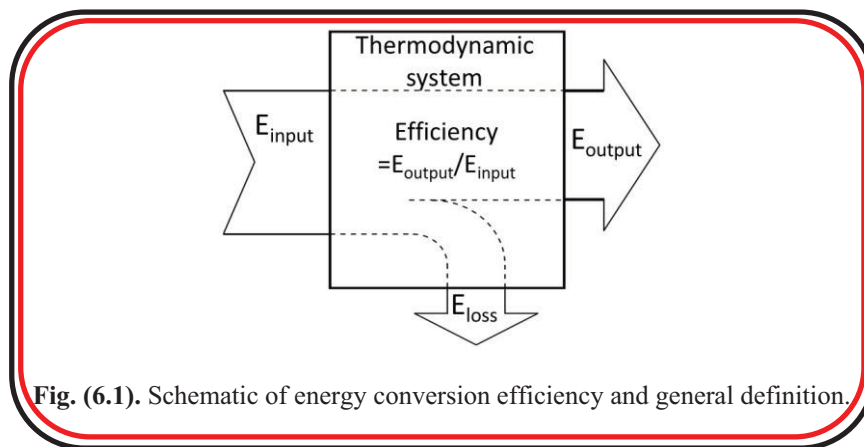

Fig. (6.1). Schematic of energy conversion efficiency and general definition.

In traditional power plants, the chemical energy in fossil fuels, such as coals and natural gases, is converted to electricity through heat engines, usually steam turbines. The efficiency is commonly expressed in terms of Heat Rate:

$$\text{Heat Rate} = \frac{\text{Thermal Energy Input}}{\text{Electrical Energy Output}} \quad \longrightarrow \quad 1$$

Though the above definition is dimensionless, Heat Rate is often written as energy per energy, such as BTU/KWh and MJ/KWh. The average annual operating heat rate of the U.S. coal-fired power plants is approximately 10,400 Btu/kWh, according to the data in 2015 [1]. To convert to a percentage of efficiency, one can divide the equivalent Btu content of a kWh of electricity (3,412 Btu) by Heat Rate.

*#Example 1: Calculate the power plant efficiency of a Heat Rate: (a) 10,500 Btu and (b) 7,500 Btu.*

*Solution:*

$$(a) \text{ Efficiency} = \frac{3,412 \text{ Btu}}{\text{Heat Rate}} = \frac{3,412 \text{ Btu}}{10,500 \text{ Btu}} = 32.5\%;$$

$$(b) \text{ Efficiency} = \frac{3,412 \text{ Btu}}{7,500 \text{ Btu}} = 45.5\%.$$

Table 6.1 lists the heat rates of power plants using different energy resources.

**Table 6.1 Approximate Heat Rates for electricity net generation [2].**

Type of Power Plant	Approximate Heat Rate (BTU/kWh)
Coal	10,500
Petroleum	11,100
Natural Gas	7,800
Nuclear	10,500
Noncombustible Renewable Energy	9,100

## 6.2. EFFICIENCIES IN POWER PLANT

In a power plant, various components are installed to enable power generation, such as steam turbines, rotating electrical generators, boilers, cooling towers, and heat exchangers. Each of these components operates at a specific efficiency. The product of all of the different efficiencies is the overall plant efficiency.

- a) Steam turbines are popular heat engines in power plants. They convert the thermal energy in steam to mechanical energy at an efficiency as high as about 40%.
- b) The mechanical energy in the form of spinning movement of the shaft is converted to electricity by a rotating electrical generator at an efficiency that may be over 95%.
- c) i.) In traditional power plants, boilers produce steam by converting the chemical energy in fossil fuels to heat through combustion and then use the heat to vaporize liquid water for steam turbines. Large central station coal-fired steam generators can convert more than 90% of the chemical energy in the coal to steam. Smaller natural-gas-fueled boilers are about 80% efficient.  
  
ii.) In nuclear power plants, heat is generated by the nuclear reaction in a reactor, which converts the energy in nuclear fuels to steam production.  
  
iii.) In centralized solar thermal power plants, the thermal energy source comes directly from the sun. High-grade thermal energy is generated by reflecting the solar beams by 100-1,000 mirrors to a single receiver at a reflectance above 90%. The thermal energy at the receiver is then transported and stored using molten salts. During the peak power hours, molten salts release heat to produce steam for steam turbine power generation.

To remove the heat rejected in steam turbine operation, a cooling tower system is installed to deliver the heat rejected by the condenser of a steam turbine via the cooling tower water to the ambient. The energy consumed for pumping cooling tower water and blowing air reduces the overall power-plant efficiency. In addition, water from rivers, lakes, or oceans is also commonly used for heat rejection.







# WIND TUNNEL

## 7.1. INTRODUCTION

Wind tunnels provide controlled air streams to study aerodynamic and fluid flow phenomena. They are frequently used to replicate the actions of an object flying or moving in an air stream, such as airplanes or vehicles. Table 7.1 lists several types of wind tunnels. Most wind tunnels are designed to have a uniform velocity profile in the test section at a low turbulence level. The testing object is placed in the test section for flow visualization and quantitative measurements such as lift and drag forces. To create an air flow, electric fans are usually used to blow air in or out of the tunnel. In large wind tunnels for testing real-size airplanes, rockets, or cars, powerful fans are required to generate a wind speed comparable with real conditions.

A pitot tube is a fluid device widely used to measure flow velocity. It is named after Henri Pitot who invented the device to determine the flow rate of the Seine River in Paris in 1732. The basic structure is a small-diameter tube with its open end facing the flow. It is now a common device for measuring the flow speed in wind tunnels and is widely equipped in airplanes for monitoring their speeds, as shown in Fig. (S7.1). Note that there were several fatal aircraft accidents in the past due to ice-plugged pitot tubes or static ports. The aircraft autopilots and real pilots could not cope with the bizarre airspeed or altitude data from plugged ports, causing aircraft uncontrollable dives and stalls.

Table 7.1. Types of wind tunnels.

Type	Remark	Image
Subsonic Tunnel	For a Mach number $(M) < 0.4$ . It may be open-return or closed-return type with air moved by axial fans.	
Transonic Tunnel	For $0.75 < M < 1.2$ . It is designed similarly to subsonic wind tunnels. Perforated/slotted walls are required to reduce wall shock reflection.	
Supersonic Tunnel	For $1.2 < M < 5$ . The Mach number and flow are determined by the nozzle geometry. It is usually equipped with a drying or pre-heating facility.	
Hypersonic Tunnel	For $5 < M < 15$ . It is designed to simulate the typical features of hypersonic flows, e.g. compression shocks, boundary layer, entropy layer, and viscous interaction zones.	

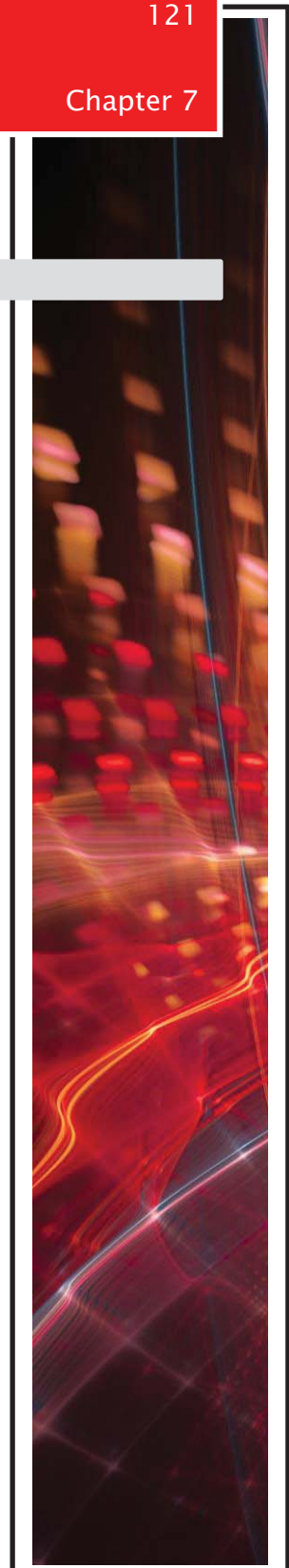

## 7.2. BERNOULLI EQUATION

Bernoulli's equation is frequently used to solve a set of fluid problems without dealing with the partial differential form of the Navier-Stokes equations. It states that an increase in the fluid velocity occurs simultaneously with a decrease in fluid's static pressure or potential energy. The equation is named after Daniel Bernoulli, who was a Swiss mathematician and physicist and is particularly remembered for his applications of mathematics to fluid mechanics and his pioneering work in probability and statistics [1]. In 1752, Leonhard Euler derived Bernoulli's equation in its usual form [2, 3].

Bernoulli's equation can be derived directly from the Navier-Stokes equation under assumptions. It has various forms determined by the assumptions according to specific problems. Popular assumptions are:

1. Inviscid flow;
2. Steady-state flow;
3. Incompressible flow;
4. Along a streamline or in irrotational flow.

With these assumptions, Bernoulli's equation can be written in concise expression as below:

$$p + \frac{1}{2}\rho u^2 + gz = \text{const} \quad \longrightarrow \quad 1$$

where  $p$  is pressure,  $\rho$  is density,  $u$  is velocity,  $g$  is specific weight, and  $z$  is elevation. When the streamline is horizontal, *i.e.*  $z=\text{constant}$ , the above equation changes to:

$$p + \frac{1}{2}\rho u^2 = \text{const} \quad \longrightarrow \quad 2$$

where on the left side, the first term  $p$  is referred to as the static pressure, and the second is the dynamic pressure, which is directly related to the fluid velocity  $u$ . Their summation denotes the total or stagnation pressure. Fig. (7.1) elucidates the static and stagnation pressures at different locations. In practice, we can assume the static pressure at the wall tap in the figure is approximately the same as that near the stagnation point. Thus, their difference, in terms of the hydraulic height  $\Delta H$ , directly measures the dynamic pressure.





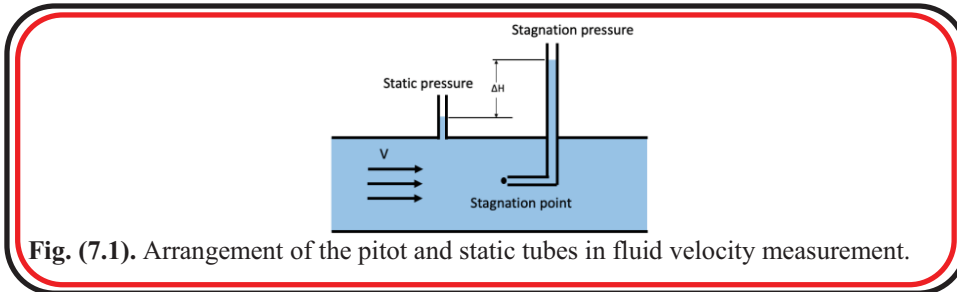

Fig. (7.1). Arrangement of the pitot and static tubes in fluid velocity measurement.

Due to its simplicity without any differential terms, Bernoulli's equation, which describes the basic pressure and velocity relationship, is frequently adopted to study fluid problems and to develop/design flow devices. Successful examples include the pitot tubes that are widely used in wind tunnels and airplanes and the Bernoulli-type flow meters, such as Venturi tubes and Orifice plates, popularly used in industry. The former will be introduced in the next section, while the latter are discussed in Chapter 5.

### 7.3. PITOT-STATIC TUBE AND VELOCITY MEASUREMENT

A pitot-static tube design is shown in Fig. (7.2), in which the pitot tube is in the middle to measure the total pressure, and the static tube is integrated to measure the static pressure. Though the two pressures in the figure are measured at two locations, one can assume the static or total pressures are approximately the same at the two locations. Thus, their difference, as measured directly by a pressure transducer or U-tube manometer in applications, will give the dynamic pressure.

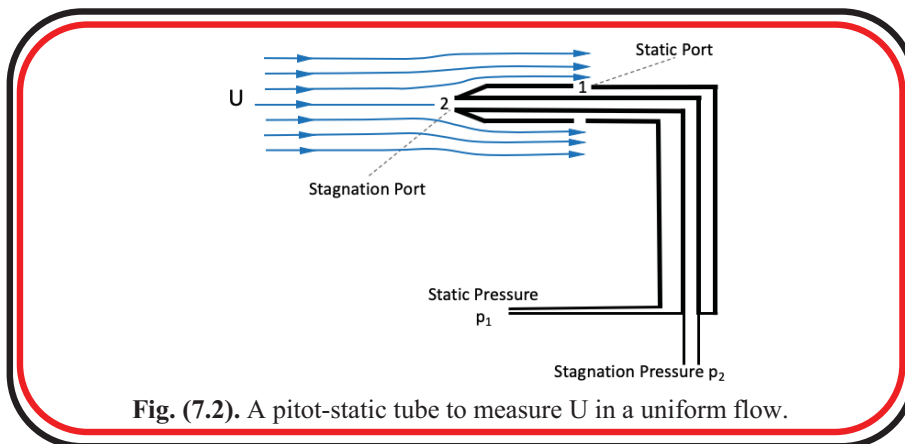
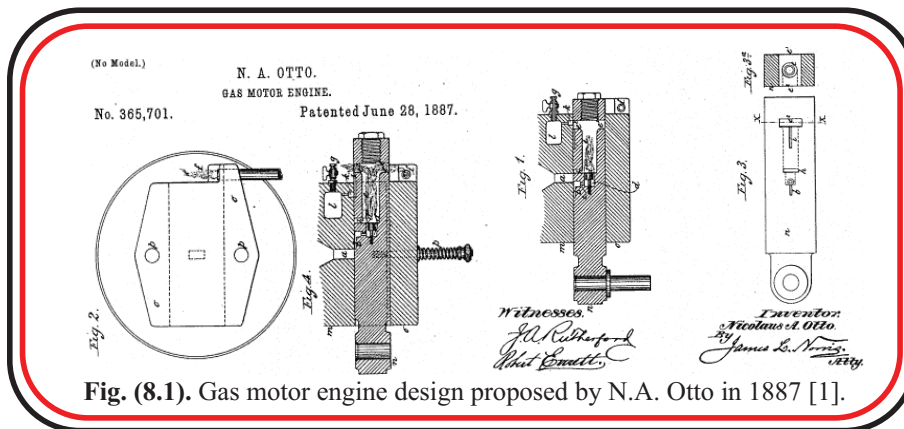

Fig. (7.2). A pitot-static tube to measure  $U$  in a uniform flow.

## OTTO AND DIESEL CYCLES

### 8.1. INTRODUCTION

Otto and Diesel cycle engines play an important role in our transportation and energy use. They are typically reciprocating heat engines that convert the thermal energy from fuel combustion to mechanical energy in the form of piston movement. The mechanical energy further drives a vehicle over a distance. The Otto and diesel cycle engines are the most common engine in passenger cars, light trucks, and other applications where small (10 Hp) to medium power (500 Hp) is required. Some large turbo supercharged radial aircraft engines reach 5,000 Hp. Applications of small power, such as lawnmowers and hand-held devices like trimmers and chain saws, require a level of 100-1,000 W power. Typical values of their thermal efficiency are 30-35% for Otto cycle engines and 30-40% for Diesel engines. Small utility-type engines may have ~20% efficiency due to simple design and control. While the basic principles of these reciprocating engines have not changed significantly since invention, advances in fuel induction, ignition systems, and exhaust emission controls have improved economy and performance and reduced pollution.



### 8.2. OTTO AND DIESEL CYCLES

A working four-stroke engine with an igniting apparatus was first developed by a German engineer Nicolaus Otto. Fig. (8.1) shows Otto's original patent. Gasoline engines, commonly used in passenger cars, are often called Otto cycle engines, which ignite the compressed mixture of gasoline vapor and air using spark plugs. Different from gasoline engines, diesel engines inject fuel into the compressed air in the cylinder, which is then ignited by the hot air. The ideal closed-system Otto cycle consists of four basic processes that occur in two strokes of the piston in the cylinder. It differs from the Carnot cycle in the

processes of heat interactions, which occur under constant volume instead of constant temperature. For the diesel cycle, the heat addition is under constant pressure due to the relatively long combustion process comparing with the Otto cycle. Table 8.1 summarizes the ideal Otto and diesel cycle processes and thermodynamic equations.

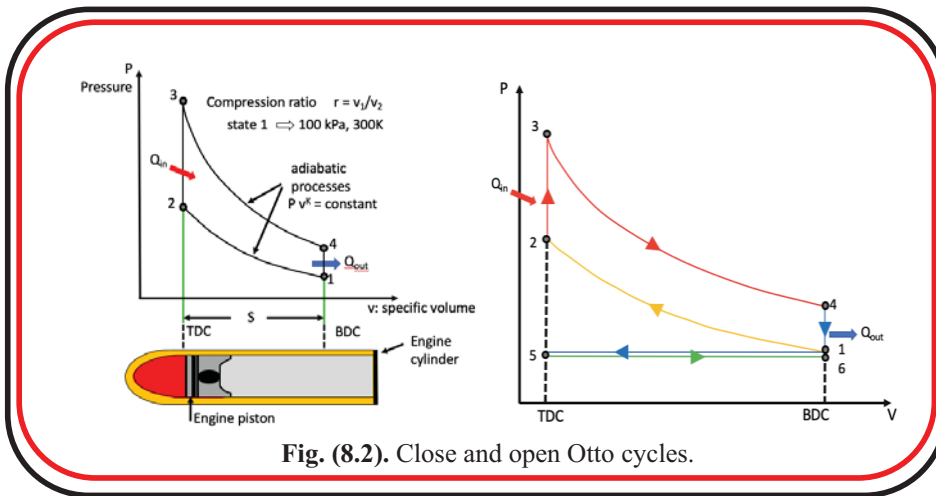

Fig. (8.2). Close and open Otto cycles.

The real Otto cycle is an open system with two extra strokes required in the practical implementation of the Otto cycle - one extra stroke at the end of the expansion (power) stroke to exhaust the burnt fuel followed by an extra stroke to intake a new fuel/air mixture, as shown in Fig. (8.2). The theoretical thermal efficiency  $\eta_{th}$  is given by:

$$\eta_{th} = \frac{W_{out}}{Q_{in}} = 1 - \frac{Q_{out}}{Q_{in}} \quad \longrightarrow \quad 1$$

Table 8.1. Otto and diesel cycle processes and equations.

Otto Cycle	Energy Eq. (1 <sup>st</sup> law)	Entropy Eq.	Ideal Path
Compression	$u_2 - u_1 = -{}_1w_2$	$s_2 - s_1 = (0/T) + 0$	$q = 0, s_1 = s_2$
Combustion	$u_3 - u_2 = q_H$	$s_3 - s_2 = \int dq_H/T + 0$	$v_3 = v_2 = C$
Expansion	$u_4 - u_3 = -{}_3w_4$	$s_4 - s_3 = (0/T) + 0$	$q = 0, s_3 = s_4$
Heat rejection	$u_1 - u_4 = -q_L$	$s_1 - s_4 = - \int dq_L/T + 0$	$v_4 = v_1 = C$

(Table 8.1) cont....

Diesel Cycle	Energy Eq. (1 <sup>st</sup> law)	Entropy Eq.	Ideal Path
Compression	$u_2 - u_1 = -{}_1w_2$	$s_2 - s_1 = (0/T) + 0$	$q = 0, s_1 = s_2$
Combustion	$u_3 - u_2 = q_H - {}_2w_3$	$s_3 - s_2 = \int dq_H/T + 0$	$P_3 = P_2 = C$
Expansion	$u_4 - u_3 = -{}_3w_4$	$s_4 - s_3 = (0/T) + 0$	$q = 0, s_3 = s_4$
Heat rejection	$u_1 - u_4 = -q_L$	$s_1 - s_4 = - \int dq_L/T + 0$	$v_4 = v_1 = C$

### 8.2.1. Otto Cycle Engine

Through the isentropic compression-expansion relationships for a calorically perfect gas (CPG), the Otto cycle efficiency  $\eta_{th,Otto}$  can be derived as below:

$$\eta_{th,Otto} = 1 - \frac{1}{r_v^{k-1}} \quad \longrightarrow \quad 2$$

where k is the ratio of specific heats and  $r_v$  is the volumetric compression ratio.

#Example 1: for  $k = 1.4$  and  $r_v = 8.5$ , calculate the Otto cycle efficiency! What should  $r_v$  be in order to achieve  $\eta_{th,Otto} = 90\%$ ?

Solution:

Using Equation 2,

$$\eta_{th,Otto} = 1 - \frac{1}{8.5^{(1.4-1)}} = 57.5\%$$

In order to achieve 90% efficiency,

$$1 - \frac{1}{r_v^{k-1}} = 90\% \rightarrow r_v = 300$$

$\eta_{th,Otto}$  is the maximum possible efficiency under this engine configuration, which is less than the Carnot efficiency operating between the maximum and minimum temperatures. It is against this maximum that actual engines should

# REFRIGERATION

## 9.1. INTRODUCTION

Refrigerators and air conditioners are popular and important devices in our daily lives. The former provides a low-temperature environment to store food and drink, while the latter reduces the indoor temperature to a comfortable level. In nature, we observe that heat flows from a higher temperature toward a lower temperature. To reverse the heat flow from a low to high temperature, mechanical work needs to be added to enable mechanical refrigeration, by which a low-temperature environment is created for food saving or air conditioning. The most important feature of mechanical refrigeration is its high efficiency, usually called the coefficient of performance (COP): the COP of residential refrigerators is usually above one, and air conditioners can achieve even five. While other refrigeration methods have been developed, based on different physical principles, such as vortex tubes and thermoelectric coolers, their efficiencies, in general, are much less than one, and we use them for special applications where their other characteristics make them attractive.

Prior to the invention of the practical vapor compression mechanical refrigeration equipment by James Harrison in 1851, refrigeration in temperature latitudes was accomplished by harvesting ice in the winter season and storing it in large barns insulated with straw. The ice was preserved for cold food storage in warm seasons, either on the farm or for delivery to residential and commercial units using iceboxes. Trade in ice goes back at least 3,000 years, and with improved insulation and harvesting techniques, became a large trade by the middle of the 1800's. With expanding demand, high-quality ice supplies became more difficult to attain. Around the same time, the first vapor-compression mechanical systems for making ice began to displace harvested ice. In the late 19th century, ice was even used to provide space cooling. The use of ice led to defining a unit in refrigeration, the "ton," also called a refrigeration ton. One ton is defined as the rate of heat transfer that results in the freezing or melting of 1 ton (2,000 lb) of pure ice at 0 °C (32 °F) in 24 hours. It is equal to 12,000 British thermal units per hour. In addition to refrigeration, the cycle can be used for heating at a very high efficiency or COP by using the heat released on the high-temperature or condenser side.

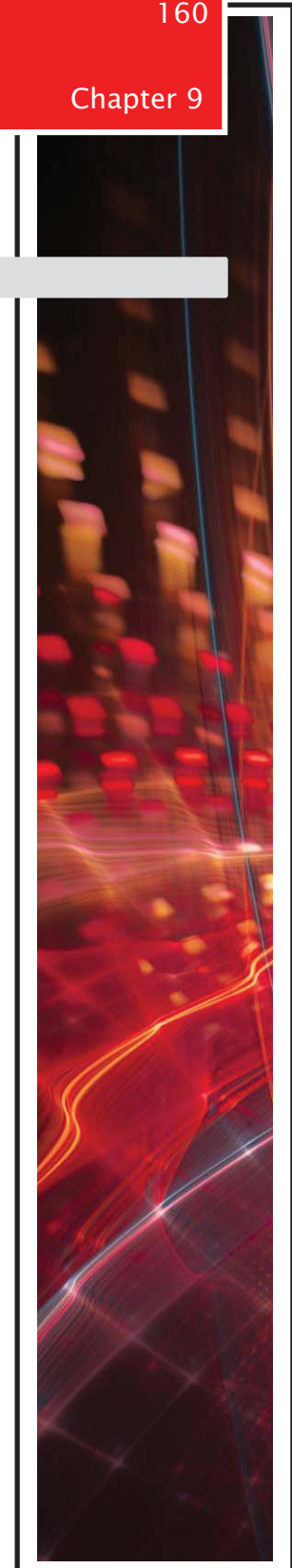

## 9.2. REFRIGERATION CYCLE

### 9.2.1. Reversible Carnot Cycle

The fundamental basis of initial analysis and design for mechanical refrigeration is the Carnot cycle, which produces work from two thermal reservoirs with heat flow from  $T_H$  to  $T_L$ . Since the Carnot cycle is reversible, theoretically, it can be used as a refrigerator as well, which drives a heat flow from  $T_L$  to  $T_H$  by mechanical work. The vapor compression, heat rejection, and heat addition from the load are all feasible with practical components, *i.e.* a compressor and two heat exchangers, respectively. The difficult remaining part of the Carnot refrigeration cycle is the change of state from a saturated liquid at high pressure to a cold vapor-liquid mixture at low pressure in the evaporator. In principle, this could be done in a power-producing device such as a turbine. Although this is done where large volumes of compressed and liquefied gases are used (*e.g.* oil refineries, compressed natural gas plants, and the like), most refrigeration systems, even large ones, are far too small for this to be practical.

Instead, the typical method of accomplishing the change of state in mechanical refrigeration is to use a simple *throttling device (or valve)* to drop the pressure and accept the loss of efficiency since no power is obtained. A pressure drop occurs across flow restriction such as a partly closed valve due to turbulent dissipation in the vortical eddies downstream of the valve and others. When a saturated liquid passes through an ideal insulated throttling valve, vaporization takes place because the pressure is reduced. Fig. (9.1) shows the major components of a refrigeration cycle.

### 9.2.2. Refrigeration Cycle

An ideal refrigeration cycle consists of two constant-pressure processes with heat transfer, one isentropic process, and one constant-h process, as shown in Figs. (9.1 and 9.2):



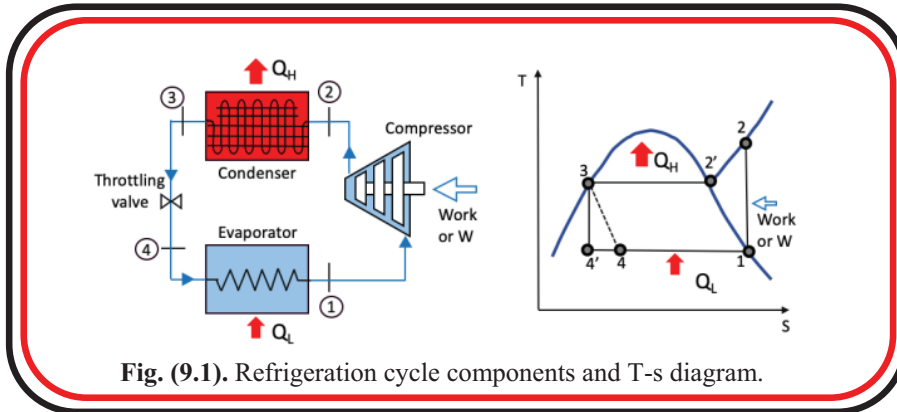

Fig. (9.1). Refrigeration cycle components and T-s diagram.

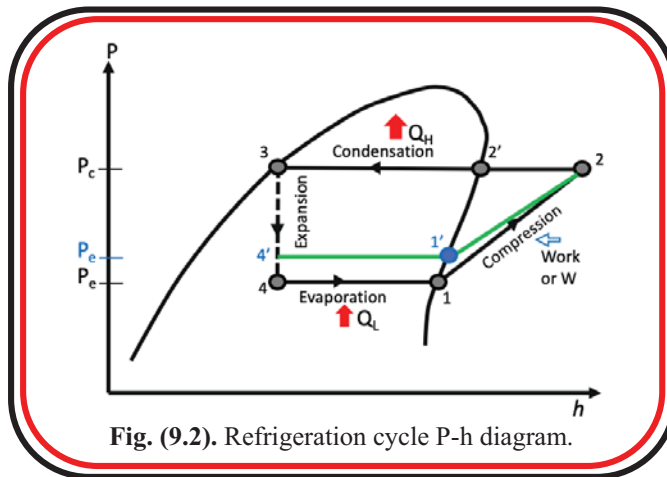

Fig. (9.2). Refrigeration cycle P-h diagram.

**1-2 Vapor Compression:** Ideal isentropic **compression** of saturated refrigerant vapor to superheated vapor.

**2-3 Heat Rejection:** Ideal constant-pressure phase change in a **condenser** from the super-heated vapor state to a saturated liquid. Heat must be rejected to the environment. Note that this consists of first *sensible* heat transfer from the super-heated state to saturated vapor followed by *latent* heat transfer from the saturated vapor to saturated liquid.

**3-4 Throttling Valve:** Isenthalpic **throttling** of the high pressure saturated liquid to a cold mixture at the low evaporator pressure.

**4-1 Heat Addition:** Ideal constant-pressure evaporation of the cold mixture to saturated vapor in the **evaporator**. Heat addition is from the **load**.

While the whole refrigeration system is a closed cycle, we can analyze each component separately as an open-system device. The analysis for the



# REPORT PREPARATION

## 10.1. OVERVIEW

To formally document a laboratory experiment, a written technical report is prepared. However, it should be noted that detailed lab notes compiled during the experiment are essential, so they can be used later in the full written report.

The overall goal for any laboratory report is to summarize an experiment efficiently for an intended audience. Therefore, knowing who will read the laboratory report (*e.g.* researchers in a similar field in a technical journal, business leaders in a company as an internal white paper, or the general public for mass consumption) will dictate the style, the tone and the level of technical jargon needed in the written work. After identifying the target audience, the lab report should explain the purpose of the experiment, the research questions answered, the experimental procedures, the data observed, the analysis method and the results.

## 10.2. REPORT FORMAT AND CONTENTS

In general, the basic components in a typical lab report can be organized into the following outline:

- I. Abstract or Summary
- II. Introduction
- III. Methods
- IV. Results and Discussions
- V. Conclusions
- VI. References

The abstract or summary is a short overview of the entire lab experiment placed at the beginning of the full lab report. It provides enough detail so the reader can quickly assess if the full report is interesting enough to warrant further attention. Following the abstract is the introduction that describes existing

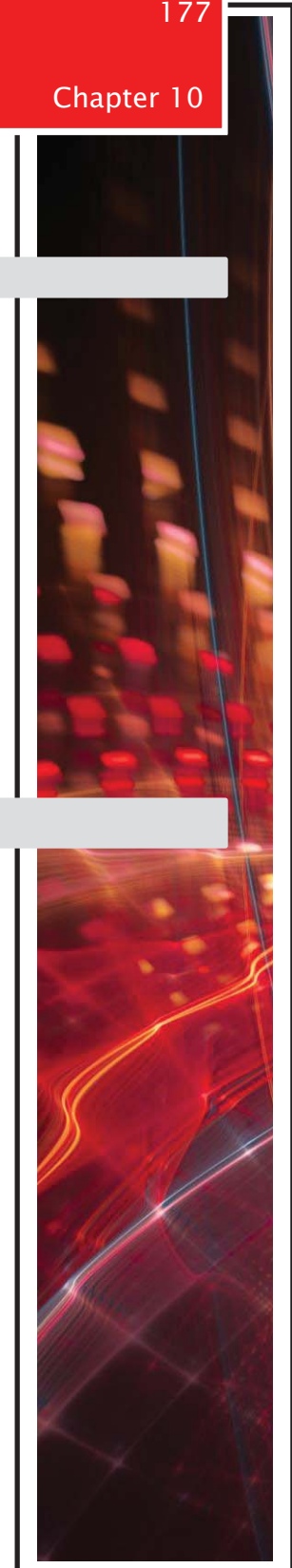



literature and research, current limitation and challenges, and research questions to be answered in the current report. The methods section will describe the experiment in detail, including mathematical equations, apparatus, and procedures. The results and discussion section will document the data, the analysis, and the relevant figures, along with in-depth discussions on how the experimental data can be interpreted. In the end, the conclusion section highlights the major findings from the lab experiment. Of note, as all experiments will involve data measurements and calculations, careful attention must be paid to proper dimension, unit, and number formatting, as well as observing any graphing and charting etiquette.

The following are the detailed description for each lab report component:

### **I. Abstract or Summary**

The objective of this section is to provide an overview of the experiment in a very short, succinct format without mathematical equations, tables, figures, references, abbreviations, and acronyms. A concise and factual abstract is desirable, and in some cases, there is a maximum word count depending on the intended audience, *e.g.* a journal publisher, technical organization or academic institution. The main content in an abstract includes the purpose of the work, what was done, the brief procedures, and main conclusions or key findings. This section should provide the readers an idea about the subject and main results covered in the report, enabling a quick decision whether to proceed reading the full report or not. A well-written abstract or summary attracts attention and encourages readers to examine the rest of the report in detail.

### **II. Introduction**

The objective of this section is to provide a context for the experimental work and methods. A review of previous work on the same subject should be included with critics or comments, followed by highlighting inadequacies, challenges, and limitations. Identifying major problems with the current state of knowledge in the field will help the readers understand the relevance and the broader impacts. The motivation and a brief introduction of the experimental work in the report at the end of this section will address the main challenges and the key research questions.

### **III. Methods**

The objective of this section is to describe the applicable theoretical concepts, mathematical equations, and experimental methods applicable for the experi-



ment. This section enables readers to understand relevant theories in detail and verify the validity of the experiment, and aids in the interpretation of the experimental data.

To describe the theories and equations, a standard format with consistent symbols should follow to facilitate readers' understanding, such as each equation per line followed by succinct descriptions defining all the variables. Each formula should be properly labeled with a number for readers to keep track of when the equation is cited in a later section.

To describe the experimental method, the main apparatus and procedures should be given and listed in detail. Sufficient information must be provided for readers to understand what equipment was used and what was done step by step. In some cases, major specific apparatus brand, model, and precision limits should be given. A flow chart or tabulated procedure can be added to visually show the experimental steps.

#### **IV. Results and Discussion**

The objective of this section is to present the results in a style and form meeting the needs of the intended readers. Tabular and graphical presentations are usually used to show important results and findings clearly. A discussion should accompany each figure or table to explain how to understand the graphic and how the results can be interpreted and identify any similarities, differences, or trends to be seen. Depending on the guidelines provided by a journal publisher, technical organization or academic institution, the standard format of figures and tables should be used to facilitate the understanding and avoid any confusion.

#### **V. Conclusions**

This section aims to discuss the results and important findings and then draw a conclusion. Major quantitative results are often located in this section. The conclusion is as important as the abstract or summary because most readers first go through these two sections before deciding to read the rest of the report. In some cases, suggestions and future works can be outlined at the end of this section.



**Universal Constants**

Standard Gravitational Acceleration	$g = 9.80665 \text{ m/s}^2 = 32.1742 \text{ ft/s}^2$
Speed of Light	$c = 2.998 \times 10^8 \text{ m/s}$
Stefan-Boltzmann Constant	$\sigma = 5.670 \times 10^{-8} \text{ W/m}^2.\text{K}^4$ $= 0.1712 \times 10^{-8} \text{ Btu/h.ft}^2.\text{R}^4$
Universal Gas constant	$\bar{R} = 8314.4 \text{ J/kg mole.K}$ $= 1.9859 \text{ Btu/lbmole.R}$ $= 1545.35 \text{ ft.lbf/lbmole.R}$

Conversion Factor	To Convert from	To	Multiply by
Energy	Btu	J	1055.0
	cal	J	4.186
	kWh	kJ	3600
	ft.lbf	Btu	0.00128507
	hp.h	Btu	2545
Force	dyn	N	$10^{-5}$
	lbf	N	4.4482
	Btu/h.ft.F	W/m.C	1.7307
Thermal Conductivity	Btu/h.ft <sup>2</sup> .F	W/m <sup>2</sup> .C	5.6782
Length	ft	m	0.3048
	in	cm	2.540
	m	cm	100
	μm	m	$10^{-6}$
	mile	km	1.60934
Mass	lbm	kg	0.4536
	slug	lbm	32.174
	ton (metric)	kg	1000
	ton (metric)	lbm	2204.6
	ton (short)	lbm	2000
Power	Btu/h	W	0.293
	Btu/s	W	1055.04
	hp	W	745.7
	hp	ft.lbf/s	550
Pressure	atm	kPa	101.325
	bar	kPa	100
	lbf/in <sup>2</sup> (psi)	kPa	6.895
	atm	psi	14.696
	atm	cm Hg at 0 C	76.0
	atm	cm H <sub>2</sub> O at 4 C	1033.2
Temperature	Deg. K <sup>1</sup>	R	9/5
	Deg. R	K	5/9
Volume	cm <sup>3</sup>	m <sup>3</sup>	$10^{-6}$
	ft <sup>3</sup>	m <sup>3</sup>	0.02832
	gallon (US)	m <sup>3</sup>	0.0037854
	gallon (US)	ft <sup>3</sup>	0.13368
	liter	m <sup>3</sup>	$10^{-3}$

<sup>1</sup>The following relations should be used for temperature conversion:

Deg C to Deg. K	Deg K = Deg C + 273.15
Deg. F to Deg. C	Deg. C = (5/9)(Deg. F - 32)
Deg. F to Deg R	Deg. R = Deg. F + 459.67

---

**Mathematical Basics and Relations**

---

1. *Definitions*(a) Dyadic product.  $(\vec{a}\vec{c})_{ij} = a_i c_j$ . ( $\vec{a}\vec{c}$  is a tensor.)

(b) Double dot product.

$$\vec{\sigma} : \vec{\tau} = \sum_i \sum_j \sigma_{ij} \tau_{ji}.$$

(c) A tensor operating on a vector from the right yields a vector.

$$\vec{a} \cdot \vec{\tau} = \sum_i \sum_j \vec{e}_i a_j \tau_{ji}.$$

(d) Transpose of a tensor.

$$(\vec{\tau}^*)_{ij} = \tau_{ji} \quad \text{or} \quad \vec{\tau} \cdot \vec{a} = \vec{a} \cdot \vec{\tau}^*.$$

(e) Product of two tensors.

$$(\vec{\tau} \cdot \vec{\sigma}) \cdot \vec{v} = \vec{\tau} \cdot (\vec{\sigma} \cdot \vec{v}) \quad \text{or} \quad (\vec{\tau} \cdot \vec{\sigma})_{ij} = \sum_k \tau_{ik} \sigma_{kj}.$$

(f) The divergence of a tensor is a vector.

$$\nabla \cdot \vec{\tau} = \sum_i \sum_j \vec{e}_i \left( \frac{\partial \tau_{ji}}{\partial x_j} \right).$$

(g) Laplacian of a scalar.

$$\nabla^2 \Phi = \nabla \cdot \nabla \Phi = \sum_i \left( \frac{\partial^2 \Phi}{\partial x_i^2} \right)$$

(h) Gradient of a vector.  $(\nabla \vec{v})_{ij} = \partial v_j / \partial x_i$ .(i) Laplacian of a vector.  $\nabla^2 \vec{v} = \nabla \cdot \nabla \vec{v} = \nabla(\nabla \cdot \vec{v}) - \nabla \times \nabla \times \vec{v}$ .2. *Algebra*(a)  $\vec{\tau} : (\vec{a}\vec{b}) = \vec{b} \cdot (\vec{\tau} \cdot \vec{a})$ .(b)  $(\vec{u}\vec{v}) : (\vec{w}\vec{z}) = (\vec{u}\vec{w}) : (\vec{v}\vec{z}) = (\vec{u} \cdot \vec{z})(\vec{v} \cdot \vec{w})$ .(c)  $\vec{a} \cdot (\vec{b}\vec{c}) = (\vec{a} \cdot \vec{b})\vec{c}$ .(d)  $(\vec{a}\vec{b}) \cdot \vec{c} = \vec{a}(\vec{b} \cdot \vec{c})$ .(e)  $\vec{a} \times (\vec{b} \times \vec{c}) = \vec{b}(\vec{a} \cdot \vec{c}) - \vec{c}(\vec{a} \cdot \vec{b})$ .(f)  $\vec{u} \cdot (\vec{v} \times \vec{w}) = \vec{v} \cdot (\vec{w} \times \vec{u})$ .(g)  $(\vec{u} \times \vec{v}) \cdot (\vec{w} \times \vec{z}) = (\vec{u} \cdot \vec{w})(\vec{v} \cdot \vec{z}) - (\vec{u} \cdot \vec{z})(\vec{v} \cdot \vec{w})$ .(h)  $\vec{v} \cdot (\vec{\tau}^* \cdot \vec{w}) = \vec{w} \cdot (\vec{\tau} \cdot \vec{v})$ .3. *Differentiation of products*(a)  $\nabla \phi \psi = \phi \nabla \psi + \psi \nabla \phi$  (a vector).(b)  $\nabla \phi \vec{v} = \phi \nabla \vec{v} + (\nabla \phi) \vec{v}$  (a tensor).

- (c)  $\nabla(\vec{a} \cdot \vec{c}) = \vec{a} \cdot \nabla \vec{c} + \vec{c} \cdot \nabla \vec{a} + \vec{a} \times \nabla \times \vec{c} + \vec{c} \times \nabla \times \vec{a}$   
 $= (\nabla c) \cdot \vec{a} + (\nabla a) \cdot \vec{c}$  (a vector).
- (d)  $\nabla \cdot (\phi \vec{v}) = \phi \nabla \cdot \vec{v} + \vec{v} \cdot \nabla \phi$  (a scalar).
- (e)  $\nabla \cdot (\vec{v} \times \vec{w}) = \vec{w} \cdot (\nabla \times \vec{v}) - \vec{v} \cdot (\nabla \times \vec{w})$  (a scalar).
- (f)  $\nabla \times (\phi \vec{v}) = \phi \nabla \times \vec{v} + (\nabla \phi) \times \vec{v}$  (a vector).
- (g)  $\nabla \times (\vec{b} \times \vec{c}) = \vec{b}(\nabla \cdot \vec{c}) - \vec{c}(\nabla \cdot \vec{b}) + \vec{c} \cdot \nabla \vec{b} - \vec{b} \cdot \nabla \vec{c}$  (a vector).
- (h)  $\nabla \cdot (\vec{a} \vec{b}) = (\nabla \cdot \vec{a}) \vec{b} + \vec{a} \cdot \nabla \vec{b}$  (a vector).
- (i)  $\nabla \cdot (\phi \vec{\tau}) = \phi \nabla \cdot \vec{\tau} + (\nabla \phi) \cdot \vec{\tau}$  (a vector).
- (j)  $\nabla \cdot (\vec{u} \cdot \vec{\tau}) = \vec{\tau} : \nabla \vec{u} + \vec{u} \cdot \nabla \cdot \vec{\tau}^*$  (a scalar).

4. *Various forms of Gauss's law (divergence theorem) and Stoke's law* ( $dS$  =area element,  $dl$  = line element,  $dv$  =volume element. Integration over a closed surface or a closed curve is denoted by a circle through the integral sign. In the first case,  $\vec{dS}$  is normally outward from the surface; in the second case,  $\vec{dl}$  and  $\vec{dS}$  are related by a right-hand screw rule, that is, a right-hand screw turned in the direction of  $\vec{dl}$  advances in the direction of  $\vec{dS}$ .)

- (a)  $\oint \vec{dS} \cdot \vec{F} = \int dv \nabla \cdot \vec{F}$ .
- (b)  $\oint \vec{dS} \phi = \int dv \nabla \phi$ .
- (c)  $\oint (\vec{dS} \cdot \vec{G}) \vec{F} = \int dv \vec{F} \nabla \cdot \vec{G} + \int dv \vec{G} \cdot \nabla \vec{F}$ .
- (d)  $\oint \vec{dS} \times \vec{F} = \int dv \nabla \times \vec{F}$ .
- (e)  $\oint \vec{dS} \cdot \vec{\tau} = \int dv \nabla \cdot \vec{\tau}$ .
- (f)  $\oint \vec{dS} \cdot (\Psi \nabla \phi - \phi \nabla \Psi) = \int dv (\Psi \nabla^2 \phi - \phi \nabla^2 \Psi)$ .
- (g)  $\oint \vec{dl} \cdot \vec{F} = \int \vec{dS} \cdot \nabla \times \vec{F}$ .
- (h)  $\oint \vec{dl} \phi = \int \vec{dS} \times \nabla \phi$ .

#### 5. *Miscellaneous*

- (a)  $\nabla \cdot \nabla \times \vec{E} = 0$ .
- (b)  $\nabla \times \nabla \phi = 0$ .
- (c)  $\vec{w} \cdot \nabla \vec{v} = \sum_i \sum_j \vec{e}_i w_j \frac{\partial v_i}{\partial x_j}$ .
- (d)  $D/Dt = \partial/\partial t + \vec{v} \cdot \nabla$ .
- (e)  $D\vec{v}/Dt = \partial\vec{v}/\partial t + \frac{1}{2} \nabla v^2 - \vec{v} \times \nabla \times \vec{v}$  } where  $\vec{v}$  is the mass-average velocity.

**APPENDIX II. THERMODYNAMIC PROPERTIES OF AIR, HYDROGEN GAS, AND WATER VAPOR**
**Table A.I-1. Ideal-gas properties of air (k: 1.406 ~ 1.392)**

T	H <sup>†</sup>	U <sup>†</sup>	S <sup>**</sup>	C <sub>p</sub> <sup>*</sup>	C <sub>v</sub> <sup>*</sup>
[K]	[kJ/kg]	[kJ/kg]	[kJ/(kg·K)]	[kJ/(kg·K)]	[kJ/(kg·K)]
230	232.0409	165.5811	1.776346	0.9939	0.7069
240	242.1921	172.9011	1.789524	0.9952	0.7082
243	245.2402	175.0744	1.793309	0.9956	0.7086
250	251.7154	180.1442	1.802048	0.9966	0.7096
260	262.4987	187.4031	1.814533	0.9980	0.7110
270	272.6462	194.6583	1.826454	0.9994	0.7124
273	275.6964	196.8337	1.830082	0.9998	0.7128
280	282.8037	201.9056	1.838426	1.0008	0.7138
290	292.9554	209.1629	1.849896	1.0023	0.7153
300	303.1092	216.4244	1.861485	1.0038	0.7168
310	313.2751	223.688	1.872625	1.0053	0.7183
320	323.4352	230.9558	1.883931	1.0068	0.7198
330	333.6074	238.2278	1.894828	1.0083	0.7213
340	343.7838	245.5098	1.905932	1.0099	0.7229
350	353.9644	252.7902	1.916853	1.0115	0.7245
353	357.023	254.9819	1.920122	1.0120	0.7250
360	364.1492	260.0906	1.927815	1.0131	0.7261
370	382.2482	267.3873	1.938616	1.0147	0.7277
380	384.5593	274.6982	1.949677	1.0163	0.7293
390	394.7746	282.0212	1.960601	1.0180	0.7310
393	397.8395	284.2192	1.963892	1.0185	0.7315
400	404.9983	289.3584	1.971593	1.0197	0.7327

**Sources:**

\*Based on a third-degree polynomial equation in Y. A. Cengel, M. A. Boles, *Thermodynamics, An engineering approach*, 6<sup>th</sup> Ed. (McGraw-Hill, 2007).

† Based on data for O<sub>2</sub>(21%) + N<sub>2</sub>(79%) from NIST Chemistry WebBook.

\*\* Based on  $S = \sum_k n_k \left( c_{v,k} \log T + R \log \frac{V}{n_k} \right)$  using data from NIST Chemistry WebBook.

**Table A.I-2. Ideal-gas properties of Hydrogen gas (k: 1.404 ~ 1.403)**

T	H	U	S	C <sub>p</sub> <sup>†</sup>	C <sub>v</sub> <sup>†</sup>
[K]	[kJ/kg]	[kJ/kg]	[kJ/(kg·K)]	[kJ/(kg·K)]	[kJ/(kg·K)]
260	3655.9716	2583.9832	62.8192	14.1329	10.0089
270	3798.3412	2684.6836	63.3564	14.1883	10.0643
273 <sup>†</sup>	3842.3887	2715.7560	63.5690	14.2033	10.0793
280	3941.2068	2786.3762	63.8753	14.2357	10.1117
290	4084.0725	2888.0687	64.3764	14.2763	10.1523
300	4227.4342	2989.7613	64.8620	14.3111	10.1871
310	4370.7959	3092.1979	65.3251	14.3410	10.2170
320	4514.1576	3194.6346	65.7881	14.3666	10.2426
330	4658.0154	3297.0713	66.2239	14.3886	10.2646
340	4801.8731	3399.5079	66.6597	14.4074	10.2834
350	4946.2270	3502.4406	67.0717	14.4236	10.2996
353 <sup>†</sup>	4989.4351	3532.7869	67.2526	14.4280	10.3040
360	5090.5808	3605.3733	67.4837	14.4375	10.3135
370	5234.6866	3708.5541	67.8738	14.4494	10.3254
380	5378.7924	3811.7348	68.2640	14.4596	10.3356
390	5523.3942	3914.9156	68.6345	14.4683	10.3443
393 <sup>†</sup>	5567.4961	3945.7895	68.8038	14.4707	10.3467
400	5667.9961	4018.0963	69.0051	14.4759	10.3519

**Table A.I-3. Ideal-gas properties of Oxygen (k: 1.409 ~ 1.375)**

T	H	U	S	C <sub>p</sub> <sup>†</sup>	C <sub>v</sub> <sup>†</sup>
[K]	[kJ/kg]	[kJ/kg]	[kJ/(kg·K)]	[kJ/(kg·K)]	[kJ/(kg·K)]
230	209.1953	149.4431	6.1709	0.9108	0.6510
240	218.2582	155.9121	6.2095	0.9115	0.6517
243 <sup>†</sup>	220.8715	157.8291	6.2240	0.9117	0.6519
250	227.3523	162.4123	6.2466	0.9123	0.6525
260	236.4464	168.9126	6.2823	0.9132	0.6534
270	245.5717	175.4128	6.3167	0.9143	0.6545
273 <sup>†</sup>	248.2640	177.6587	6.3303	0.9147	0.6549
280	254.6971	181.9443	6.3500	0.9156	0.6558
290	263.8536	188.5071	6.3821	0.9170	0.6572
300	273.0102	195.0698	6.4131	0.9185	0.6587
310	282.1981	201.6638	6.4433	0.9202	0.6604
320	291.4172	208.2578	6.4725	0.9220	0.6622
330	300.6363	214.9143	6.5009	0.9240	0.6642
340	309.8866	221.5708	6.5285	0.9261	0.6663
350	319.1682	228.2273	6.5554	0.9283	0.6685
353 <sup>†</sup>	321.9528	230.2516	6.5670	0.9289	0.6691
360	328.4811	234.9463	6.5816	0.9306	0.6708
370	337.7939	241.6653	6.6072	0.9330	0.6732
380	347.1693	248.4156	6.6322	0.9355	0.6757
390	356.5446	255.1971	6.6566	0.9381	0.6783
393 <sup>†</sup>	359.3043	257.1991	6.6672	0.9389	0.6791
400	365.9825	262.0098	6.6804	0.9408	0.6810

\*Sources:

[1] Y. A. Cengel, M. A. Boles, "Thermodynamics, An engineering approach", 6<sup>th</sup> Ed. (McGraw-Hill, 2007).

[2] NIST Chemistry WebBook.



**Table A3.1** Mass conservation equations in the cartesian, cylindrical and spherical coordinates.

*Cartesian coordinates (x, y, z):*

$$\frac{\partial \rho}{\partial t} + \frac{\partial}{\partial x}(\rho u_x) + \frac{\partial}{\partial y}(\rho u_y) + \frac{\partial}{\partial z}(\rho u_z) = 0$$

*Cylindrical coordinates (r,  $\theta$ , z):*

$$\frac{\partial \rho}{\partial t} + \frac{1}{r} \frac{\partial}{\partial r}(\rho r u_r) + \frac{1}{r} \frac{\partial}{\partial \theta}(\rho u_\theta) + \frac{\partial}{\partial z}(\rho u_z) = 0$$

*Spherical coordinates (r,  $\theta$ ,  $\phi$ ):*

$$\frac{\partial \rho}{\partial t} + \frac{1}{r^2} \frac{\partial}{\partial r}(\rho r^2 u_r) + \frac{1}{r \sin \theta} \frac{\partial}{\partial \theta}(\rho u_\theta \sin \theta) + \frac{1}{r \sin \theta} \frac{\partial}{\partial \phi}(\rho u_\phi) = 0$$

**Table A3.2** Momentum equations in the cartesian coordinate.*Cartesian coordinates (x, y, z) x-direction:*

$$\rho \left( \frac{\partial u_x}{\partial t} + u_x \frac{\partial u_x}{\partial x} + u_y \frac{\partial u_x}{\partial y} + u_z \frac{\partial u_x}{\partial z} \right) = -\frac{\partial p}{\partial x} + \mu \left( \frac{\partial^2 u_x}{\partial x^2} + \frac{\partial^2 u_x}{\partial y^2} + \frac{\partial^2 u_x}{\partial z^2} \right) + \rho g_x$$

*Cartesian coordinates (x, y, z) y-direction:*

$$\rho \left( \frac{\partial u_y}{\partial t} + u_x \frac{\partial u_y}{\partial x} + u_y \frac{\partial u_y}{\partial y} + u_z \frac{\partial u_y}{\partial z} \right) = -\frac{\partial p}{\partial y} + \mu \left( \frac{\partial^2 u_y}{\partial x^2} + \frac{\partial^2 u_y}{\partial y^2} + \frac{\partial^2 u_y}{\partial z^2} \right) + \rho g_y$$

*Cartesian coordinates (x, y, z) z-direction:*

$$\rho \left( \frac{\partial u_z}{\partial t} + u_x \frac{\partial u_z}{\partial x} + u_y \frac{\partial u_z}{\partial y} + u_z \frac{\partial u_z}{\partial z} \right) = -\frac{\partial p}{\partial z} + \mu \left( \frac{\partial^2 u_z}{\partial x^2} + \frac{\partial^2 u_z}{\partial y^2} + \frac{\partial^2 u_z}{\partial z^2} \right) + \rho g_z$$

**Table A3.3** Momentum equations in the cylindrical coordinate.*Cylindrical coordinates (r, θ, z) r-direction:*

$$\begin{aligned} \rho \left( \frac{\partial u_r}{\partial t} + u_r \frac{\partial u_r}{\partial r} + \frac{u_\theta}{r} \frac{\partial u_r}{\partial \theta} - \frac{u_\theta^2}{r} + u_z \frac{\partial u_r}{\partial z} \right) \\ = -\frac{\partial p}{\partial r} + \mu \left[ \frac{\partial}{\partial r} \left( \frac{1}{r} \frac{\partial}{\partial r} (r u_r) \right) + \frac{1}{r^2} \frac{\partial^2 u_r}{\partial \theta^2} - \frac{2}{r^2} \frac{\partial u_\theta}{\partial \theta} + \frac{\partial^2 u_r}{\partial z^2} \right] + \rho g_r \end{aligned}$$

*Cylindrical coordinates (r, θ, z) θ-direction:*

$$\begin{aligned} \rho \left( \frac{\partial u_\theta}{\partial t} + u_r \frac{\partial u_\theta}{\partial r} + \frac{u_\theta}{r} \frac{\partial u_\theta}{\partial \theta} - \frac{u_r u_\theta}{r} + u_z \frac{\partial u_\theta}{\partial z} \right) \\ = -\frac{1}{r} \frac{\partial p}{\partial \theta} + \mu \left[ \frac{\partial}{\partial r} \left( \frac{1}{r} \frac{\partial}{\partial r} (r u_\theta) \right) + \frac{1}{r^2} \frac{\partial^2 u_\theta}{\partial \theta^2} + \frac{2}{r^2} \frac{\partial u_r}{\partial \theta} + \frac{\partial^2 u_\theta}{\partial z^2} \right] + \rho g_\theta \end{aligned}$$

*Cylindrical coordinates (r, θ, z) z-direction:*

$$\rho \left( \frac{\partial u_z}{\partial t} + u_r \frac{\partial u_z}{\partial r} + \frac{u_\theta}{r} \frac{\partial u_z}{\partial \theta} + u_z \frac{\partial u_z}{\partial z} \right) = -\frac{\partial p}{\partial z} + \mu \left[ \frac{1}{r} \frac{\partial}{\partial r} \left( r \frac{\partial u_z}{\partial r} \right) + \frac{1}{r^2} \frac{\partial^2 u_z}{\partial \theta^2} + \frac{\partial^2 u_z}{\partial z^2} \right] + \rho g_z$$

<b>Table A3.4</b> Momentum equations in the spherical coordinate.
<i>Spherical coordinates (r, <math>\theta</math>, <math>\phi</math>) r-direction:</i>
$\rho \left( \frac{\partial u_r}{\partial t} + u_r \frac{\partial u_r}{\partial r} + \frac{u_\theta}{r} \frac{\partial u_r}{\partial \theta} + \frac{u_\phi}{r \sin \theta} \frac{\partial u_r}{\partial \phi} - \frac{u_\theta^2 + u_\phi^2}{r} \right) = -\frac{\partial p}{\partial r} + \mu \left[ \nabla^2 u_r - \frac{2}{r^2} u_r - \frac{2}{r^2} \frac{\partial u_\theta}{\partial \theta} - \frac{2}{r^2} u_\theta \cot \theta - \frac{2}{r^2 \sin \theta} \frac{\partial u_\phi}{\partial \phi} \right] + \rho g_r$
<i>Spherical coordinates (r, <math>\theta</math>, <math>\phi</math>) <math>\theta</math>-direction:</i>
$\rho \left( \frac{\partial u_\theta}{\partial t} + u_r \frac{\partial u_\theta}{\partial r} + \frac{u_\theta}{r} \frac{\partial u_\theta}{\partial \theta} + \frac{u_\phi}{r \sin \theta} \frac{\partial u_\theta}{\partial \phi} + \frac{u_r u_\theta}{r} - \frac{u_\phi^2 \cot \theta}{r} \right) = -\frac{1}{r} \frac{\partial p}{\partial \theta} + \mu \left[ \nabla^2 u_\theta + \frac{2}{r^2} \frac{\partial u_r}{\partial \theta} - \frac{u_\theta}{r^2 \sin^2 \theta} - \frac{2 \cos \theta}{r^2 \sin^2 \theta} \frac{\partial u_\phi}{\partial \phi} \right] + \rho g_\theta$
<i>Spherical coordinates (r, <math>\theta</math>, <math>\phi</math>) <math>\phi</math>-direction:</i>
$\rho \left( \frac{\partial u_\phi}{\partial t} + u_r \frac{\partial u_\phi}{\partial r} + \frac{u_\theta}{r} \frac{\partial u_\phi}{\partial \theta} + \frac{u_\phi}{r \sin \theta} \frac{\partial u_\phi}{\partial \phi} + \frac{u_\phi u_r}{r} + \frac{u_\theta u_\phi}{r} \cot \theta \right) = -\frac{1}{r \sin \theta} \frac{\partial p}{\partial \phi} + \mu \left[ \nabla^2 u_\phi - \frac{u_\phi}{r^2 \sin^2 \theta} + \frac{2}{r^2 \sin \theta} \frac{\partial u_r}{\partial \phi} + \frac{2 \cos \theta}{r^2 \sin^2 \theta} \frac{\partial u_\theta}{\partial \phi} \right] + \rho g_\phi$

$T$ (K)	$\rho$ (kg/m <sup>3</sup> )	$\mu \cdot 10^7$ (N·s/m <sup>2</sup> )	$\nu \cdot 10^6$ (m <sup>2</sup> /s)	$k \cdot 10^3$ (W/m·K)	$\alpha \cdot 10^6$ (m <sup>2</sup> /s)	$Pr$
<b>Air</b>						
100	3.5562	71.1	2.00	9.34	2.54	0.786
150	2.3364	103.4	4.426	13.8	5.84	0.758
200	1.7458	132.5	7.590	18.1	10.3	0.737
250	1.3947	159.6	11.44	22.3	15.9	0.720
300	1.1614	184.6	15.89	26.3	22.5	0.707
350	0.9950	208.2	20.92	30.0	29.9	0.700
400	0.8711	230.1	26.41	33.8	38.3	0.690
450	0.7740	250.7	32.39	37.3	47.2	0.686
500	0.6964	270.1	38.79	40.7	56.7	0.684
550	0.6329	288.4	45.57	43.9	66.7	0.683
600	0.5804	305.8	52.69	46.9	76.9	0.685
650	0.5356	322.5	60.21	49.7	87.3	0.690
700	0.4975	338.8	68.10	52.4	98.0	0.695
750	0.4643	354.6	76.37	54.9	109	0.702
800	0.4354	369.8	84.93	57.3	120	0.709
850	0.4097	384.3	93.80	59.6	131	0.716
900	0.3868	398.1	102.9	62.0	143	0.720
950	0.3666	411.3	112.2	64.3	155	0.723
1000	0.3482	424.4	121.9	66.7	168	0.726
1100	0.3166	449.0	141.8	71.5	195	0.728
1200	0.2902	473.0	162.9	76.3	224	0.728
1300	0.2679	496.0	185.1	82	238	0.719

1400	0.2488	530	213	91	303	0.703
1500	0.2322	557	240	100	350	0.685
1600	0.2177	584	268	106	390	0.688
1700	0.2049	611	298	113	435	0.685
1800	0.1935	637	329	120	482	0.683
1900	0.1833	663	362	128	534	0.677
2000	0.1741	689	396	137	589	0.672
2100	0.1658	715	431	147	646	0.667
2200	0.1582	740	468	160	714	0.655
2300	0.1513	766	506	175	783	0.647
2400	0.1448	792	547	196	869	0.630
2500	0.1389	818	589	222	960	0.613
3000	0.1135	955	841	486	1570	0.536

$T$ (K)	$\rho$ (kg/m <sup>3</sup> )	$\mu \cdot 10^7$ (N·s/m <sup>2</sup> )	$\nu \cdot 10^6$ (m <sup>2</sup> /s)	$k \cdot 10^3$ (W/m·K)	$\alpha \cdot 10^6$ (m <sup>2</sup> /s)	$Pr$
<b>Carbon Dioxide (CO<sub>2</sub>)</b>						
280	1.9022	140	7.36	15.20	9.63	0.765
300	1.7730	149	8.40	16.55	11.0	0.766
320	1.6609	156	9.39	18.05	12.5	0.754
340	1.5618	165	10.6	19.70	14.2	0.746
360	1.4743	173	11.7	21.2	15.8	0.741
380	1.3961	181	13.0	22.75	17.6	0.737
400	1.3257	190	14.3	24.3	19.5	0.737
450	1.1782	210	17.8	28.3	24.5	0.728
500	1.0594	231	21.8	32.5	30.1	0.725
550	0.9625	251	26.1	36.6	36.2	0.721

---

600	0.8826	270	30.6	40.7	42.7	0.717
650	0.8143	288	35.4	44.5	49.7	0.712
700	0.7564	305	40.3	48.1	56.3	0.717
750	0.7057	321	45.5	51.7	63.7	0.714
800	0.6614	337	51.0	55.1	71.2	0.716

---

**Carbon Monoxide (CO)**

200	1.6888	127	7.52	17.0	9.63	0.781
220	1.5341	137	8.93	19.0	11.9	0.753
240	1.4055	147	10.5	20.6	14.1	0.744
260	1.2967	157	12.1	22.1	16.3	0.741
280	1.2038	166	13.8	23.6	18.8	0.733
300	1.1233	175	15.6	25.0	21.3	0.730
320	1.0529	184	17.5	26.3	23.9	0.730
340	0.9909	193	19.5	27.8	26.9	0.725
360	0.9357	202	21.6	29.1	29.8	0.725
380	0.8864	210	23.7	30.5	32.9	0.729
400	0.8421	218	25.9	31.8	36.0	0.719
450	0.7483	237	31.7	35.0	44.3	0.714
500	0.67352	254	37.7	38.1	53.1	0.710
550	0.61226	271	44.3	41.1	62.4	0.710
600	0.56126	286	51.0	44.0	72.1	0.707
650	0.51806	301	58.1	47.0	82.4	0.705
700	0.48102	315	65.5	50.0	93.3	0.702
750	0.44899	329	73.3	52.8	104	0.702
800	0.42095	343	81.5	55.5	116	0.705

---

Appendix V. Thermal Properties of Selected Materials\*

Thermal Properties of Selected Metallic Solids

Composition	Melting Point (K)	Properties at 300 K / 353K <sup>†</sup>				Properties at Various Temperatures (K)							
		$\rho$ (kg/m <sup>3</sup> )	$c_p$ (J/kg·K)	$k$ (W/m·K)	$\alpha \cdot 10^6$ (m <sup>2</sup> /s)	$k$ (W/m·K) / $c_p$ (J/kg·K)							
						100	200	400	500	600	700	800	
Aluminum													
Pure	933	2702	906	237	97.1	302	237	240	237	232	226	220	
			901 <sup>†</sup>	240 <sup>†</sup>		485	802	935	996	1042	1091	1149	
Alloy 2024-T6 (4.5% Cu, 1.5% Mg, 0.6% Mn)	775	2770	875	177	73.0	65	163	186		186			
						473	787	925		1042			
Alloy 195, Case (4.5% Cu)		2790	883	168	68.2			174		185			
								-		-			
Copper													
Pure	1358	8933	386	398	117	483	413	392	388	383	377	371	
			398 <sup>†</sup>	394 <sup>†</sup>		252	356	400	404	414	423	438	
Commercial bronze (90% Cu, 10% Al)	1293	8800	420	52	14		42	52		59			
							785	460		545			
Phosphor gear bronze (89% Cu, 11% Sn)	1104	8780	355	54	17		41	65		74			
							-	-		-			
Cartridge brass (70% Cu, 30% Zn)	1188	8530	380	110	33.9	75	95	137		149			
							360	395		425			
Constantan (55% Cu, 45% Ni)	1493	8920	384	23	6.71	17	19						
						237	362						
Iron													
Pure	1810	7870	443	80.3	23.1	132	94.0	69.4	61.3	54.7	48.7	43.3	
			441 <sup>†</sup>	74.1 <sup>†</sup>		216	385	486	495	566	619	686	
Armco (99.75% pure)		7870	447	72.7	20.7	95.6	80.6	65.7		53.1		42.2	
						215	384	490		574		680	
Carbon steels													
Plain carbon (Mn ≤ 1%, Si ≤ 0.1% )		7854	434	60.5	17.7			56.7		48.0		39.2	
								487		559		685	
AISI 1010		7832	434	63.9	18.8			58.7		48.8		39.2	
								487		559		685	
Carbon-silicon (Mn ≤ 1%, 0.1% < Si ≤ 0.6% )		7817	446	51.9	14.9			49.8		44.0		37.4	
								501		582		699	
Carbon-manganese- silicon (1% < Mn ≤ 1.65%, 0.1% < Si ≤ 0.6% )		8131	434	41.0	11.6			42.2		39.7		35.0	
								487		559		685	

## Stainless steels

AISI 302		8055	480	15.1	3.91			17.3		20.0		22.8
								512		559		585
AISI 304	1670	7900	477	14.9	3.95	9.2	12.6	16.6		19.8		22.6
						272	402	515		557		582
AISI 316		8238	468	13.4	3.48			15.2		18.3		21.3
								504		550		576
AISI 347		7978	480	14.2	3.71			15.8		18.9		21.9
								513		559		585
Nickel												
Pure	1728	8900	444	90.5	23.0	158	106	80.1	72.1	65.5	65.3	67.4
			461 <sup>†</sup>	84.7 <sup>†</sup>		232	383	477	527	590	524	524
Nichrome (80% Ni, 20% Cr)	1672	8400	420	12	3.4			14		16		21
								480		525		545
Inconel X-750 (73% Ni, 15% Cr, 6.7% Fe)	1665	8510	439	11.7	3.1	8.7	10.3	13.5		17.0		20.5
						-	372	473		510		546
Platinum												
Pure	2045	21450	132	71.4	25.1	77.5	72.4	71.6	72.2	73.0	74.1	75.5
			134 <sup>†</sup>	71.5 <sup>†</sup>		100	125	136	139	141	144	146
Alloy 60Pt-40Rh (60% Pt, 40% Rh)	1800	16630	162	47	17.4			52		59		65
								-		-		-
Silicon	1685	2330	712	148	89.2	884	264	98.9	76.2	61.9	50.8	42.2
			754 <sup>†</sup>	118 <sup>†</sup>		259	557	785	831	852	869	886
Silver	1235	10500	237	427	174	450	430	420	413	405	397	389
			237 <sup>†</sup>	423.8 <sup>†</sup>		187	225	239	243	248	253	258
Tungsten	3660	19300	133	178	68.3	235	197	162	149	139	133	128
			136 <sup>†</sup>	169.5 <sup>†</sup>		87	122	136	138	140	143	145

†: Properties at 353K



## Thermal Properties of Selected Nonmetallic Solids

Composition	Melting Point (K)	Properties at 300 K / 353K				Properties at Various Temperatures (K)				
		$\rho$ (kg/m <sup>3</sup> )	$c_p$ (J/kg·K)	$k$ (W/m·K)	$\alpha \cdot 10^6$ (m <sup>2</sup> /s)	$k$ (W/m·K) / $c_p$ (J/kg·K)				
						100	200	400	600	800
Carbon										
Amorphous	1500	1950	-	1.60	-	0.67	1.18	1.89	2.19	2.37
						-	-	-	-	-
Diamond, type IIa insulator	-	3500	516	2000 1831 <sup>†</sup>	-	9,800 36	4,300 197	1540 853	1344	1626
Graphite, pyrolytic	2273	2210								
$k$ ,    to layers				2000 1606 <sup>†</sup>		4980	3250	1460	930	680
$k$ , $\perp$ to layers				9.5		39	15	7.0	4.4	3.2
$c_p$			709	4.73 <sup>†</sup>		136	411	992	1406	165 0
Graphite fiber epoxy (25% vol) composite	450	1400								
$k$ , heat flow    to fibers				11.1		5.7	8.7	13.0		
$k$ , heat flow $\perp$ to fibers				0.87		0.46	0.68	1.1		
$c_p$			935			337	642	1216		
Nafion <sup>‡</sup>		2000								
Water level 3				0.185						
Water level 22				0.25						
Sulfur	392	2070	704 753 <sup>†</sup>	0.206 0.216 <sup>†</sup>	0.141	0.165 403	0.185 606			

†: Properties at 353K

‡: Water level = H<sub>2</sub>O/HSO<sub>3</sub>

This appendix presents the analytical solutions to a series of problems of heat conduction with thermal energy generation for one-dimensional (1-D) geometry under steady-state condition. The form of the heat equation differs, according to the object shape: a plane wall, a cylindrical shell, and a spherical shell. In each shape, several options are available to set the boundary conditions, determined by the real problem. Each set of boundary conditions results in specific solutions of the temperature distribution and heat rate (or heat flux).

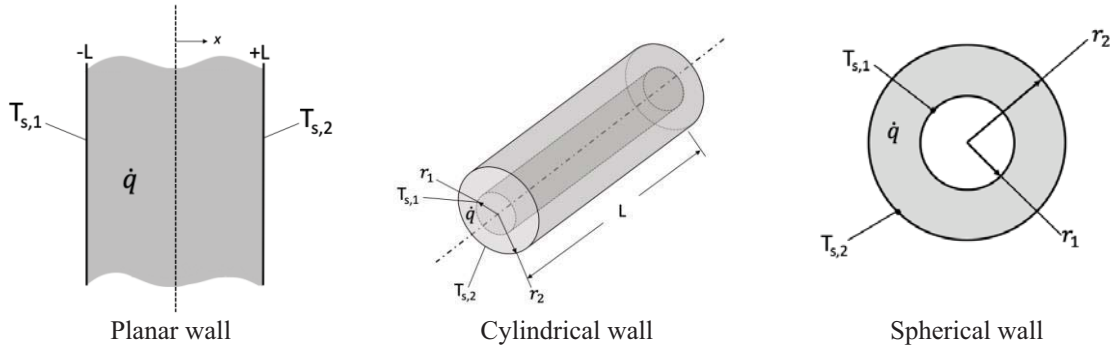

Figure A6.1. 1-D heat conduction with uniform heat generation: a plane wall with asymmetric surface conditions, a cylindrical shell, and a spherical shell.

For the three geometries in Figure A.61 with uniform temperature  $T_{s,1}$  and  $T_{s,2}$  at the two surfaces, solutions are readily obtained :

**1-D, Steady-State Solutions to the Heat Equations for Plane, Cylindrical, and Spherical Walls with Uniform Heat Generation and Asymmetrical Surface Conditions**

**Temperature Distribution**

**Plane Wall** 
$$T(x) = \frac{\dot{q}L^2}{2k} \left( 1 - \frac{x^2}{L^2} \right) + \frac{T_{s,2} - T_{s,1}}{2} \frac{x}{L} + \frac{T_{s,1} + T_{s,2}}{2}$$

**Cylindrical Wall** 
$$T(r) = T_{s,2} + \frac{\dot{q}r_2^2}{4k} \left( 1 - \frac{r^2}{r_2^2} \right) - \left[ \frac{\dot{q}r_2^2}{4k} \left( 1 - \frac{r_1^2}{r_2^2} \right) + (T_{s,2} - T_{s,1}) \right] \frac{\ln(r_2/r)}{\ln(r_2/r_1)}$$

**Spherical Wall** 
$$T(r) = T_{s,2} + \frac{\dot{q}r_2^2}{6k} \left( 1 - \frac{r^2}{r_2^2} \right) - \left[ \frac{\dot{q}r_2^2}{6k} \left( 1 - \frac{r_1^2}{r_2^2} \right) + (T_{s,2} - T_{s,1}) \right] \frac{(1/r) - (1/r_2)}{(1/r_1) - (1/r_2)}$$

**Heat Flux**

**Plane Wall** 
$$q''(x) = \dot{q}x - \frac{k}{2L}(T_{s,2} - T_{s,1})$$

---

$$\text{Cylindrical Wall} \quad q''(r) = \frac{\dot{q}r}{2} - \frac{k \left[ \frac{\dot{q}r_2^2}{4k} \left( 1 - \frac{r_1^2}{r_2^2} \right) + (T_{s,2} - T_{s,1}) \right]}{r \ln(r_2/r_1)}$$

$$\text{Spherical Wall} \quad q''(r) = \frac{\dot{q}r}{3} - \frac{k \left[ \frac{\dot{q}r_2^2}{6k} \left( 1 - \frac{r_1^2}{r_2^2} \right) + (T_{s,2} - T_{s,1}) \right]}{r^2 \left[ (1/r_1) - (1/r_2) \right]}$$

### Heat Rate

$$\text{Plane Wall} \quad q(x) = \left[ \dot{q}x - \frac{k}{2L} (T_{s,2} - T_{s,1}) \right] A_x$$

$$\text{Cylindrical Wall} \quad q(r) = \dot{q}\pi L r^2 - \frac{2\pi L k}{\ln(r_2/r_1)} \cdot \left[ \frac{\dot{q}r_2^2}{4k} \left( 1 - \frac{r_1^2}{r_2^2} \right) + (T_{s,2} - T_{s,1}) \right]$$

$$\text{Spherical Wall} \quad q(r) = \frac{\dot{q}4\pi r^3}{3} - \frac{4\pi k \left[ \frac{\dot{q}r_2^2}{6k} \left( 1 - \frac{r_1^2}{r_2^2} \right) + (T_{s,2} - T_{s,1}) \right]}{(1/r_1) - (1/r_2)}$$

---

In practice, a uniform surface heat flux or a convection boundary condition is also frequently encountered. The third kind is applied by using the overall heat transfer coefficient  $U$  in lieu of the convection coefficient  $h$ .

### Surface Heat Flux Conditions and Energy Balance for 1-D, Steady-State Solutions to the Heat Equation for Plane, Cylindrical, and Spherical Walls with Uniform Generation

---

#### Plane Wall

*Uniform Surface Heat Flux*

$$x = -L: \quad q''_{s,1} = -\dot{q}L - \frac{k}{2L} (T_{s,2} - T_{s,1})$$

$$x = +L: \quad q''_{s,2} = \dot{q}L - \frac{k}{2L} (T_{s,2} - T_{s,1})$$

*Prescribed Transport Coefficient and Fluid Flow Temperature*

$$x = -L: \quad U_1 (T_{\infty,1} - T_{s,1}) = -\dot{q}L - \frac{k}{2L} (T_{s,2} - T_{s,1})$$

$$x = +L: \quad U_2 (T_{s,2} - T_{\infty,2}) = \dot{q}L - \frac{k}{2L} (T_{s,2} - T_{s,1})$$

#### Cylindrical Wall

*Uniform Surface Heat Flux*

---

$$r = r_1 : \quad q''_{s,1} = \frac{\dot{q}r_1}{2} - \frac{k \left[ \frac{\dot{q}r_2^2}{4k} \left( 1 - \frac{r_1^2}{r_2^2} \right) + (T_{s,2} - T_{s,1}) \right]}{r_1 \ln(r_2/r_1)}$$

$$r = r_2 : \quad q''_{s,2} = \frac{\dot{q}r_2}{2} - \frac{k \left[ \frac{\dot{q}r_2^2}{4k} \left( 1 - \frac{r_1^2}{r_2^2} \right) + (T_{s,2} - T_{s,1}) \right]}{r_2 \ln(r_2/r_1)}$$

*Prescribed Transport Coefficient and Fluid Flow Temperature*

$$r = r_1 : \quad U_1(T_{\infty,1} - T_{s,1}) = \frac{\dot{q}r_1}{2} - \frac{k \left[ \frac{\dot{q}r_2^2}{4k} \left( 1 - \frac{r_1^2}{r_2^2} \right) + (T_{s,2} - T_{s,1}) \right]}{r_1 \ln(r_2/r_1)}$$

$$r = r_2 : \quad U_2(T_{s,2} - T_{\infty,2}) = \frac{\dot{q}r_2}{2} - \frac{k \left[ \frac{\dot{q}r_2^2}{4k} \left( 1 - \frac{r_1^2}{r_2^2} \right) + (T_{s,2} - T_{s,1}) \right]}{r_2 \ln(r_2/r_1)}$$

### Spherical Wall

*Uniform Surface Heat Flux*

$$r = r_1 : \quad q''_{s,1} = \frac{\dot{q}r_1}{3} - \frac{k \left[ \frac{\dot{q}r_2^2}{6k} \left( 1 - \frac{r_1^2}{r_2^2} \right) + (T_{s,2} - T_{s,1}) \right]}{r_1^2 [(1/r_1) - (1/r_2)]}$$

$$r = r_2 : \quad q''_{s,2} = \frac{\dot{q}r_2}{3} - \frac{k \left[ \frac{\dot{q}r_2^2}{6k} \left( 1 - \frac{r_1^2}{r_2^2} \right) + (T_{s,2} - T_{s,1}) \right]}{r_2^2 [(1/r_1) - (1/r_2)]}$$

*Prescribed Transport Coefficient and Fluid Flow Temperature*

$$r = r_1 : \quad U_1(T_{\infty,1} - T_{s,1}) = \frac{\dot{q}r_1}{3} - \frac{k \left[ \frac{\dot{q}r_2^2}{6k} \left( 1 - \frac{r_1^2}{r_2^2} \right) + (T_{s,2} - T_{s,1}) \right]}{r_1^2 [(1/r_1) - (1/r_2)]}$$

$$r = r_2 : \quad U_2(T_{s,2} - T_{\infty,2}) = \frac{\dot{q}r_2}{3} - \frac{k \left[ \frac{\dot{q}r_2^2}{6k} \left( 1 - \frac{r_1^2}{r_2^2} \right) + (T_{s,2} - T_{s,1}) \right]}{r_2^2 [(1/r_1) - (1/r_2)]}$$

In the foregoing configurations, a plane wall with one adiabatic surface, a solid cylinder (a circular rod), and a sphere, as shown in Figure A6.2, may be encountered. The corresponding boundary condition at the adiabatic surface follows  $dT/dx|_{x=0}=0$  or  $dT/dr|_{r=0}=0$ . The solutions are based on setting a uniform temperature  $T_s$  at  $x=L$  and  $r=r_0$ . If  $T_s$  is not known, it may be determined by the energy balance equation at the surface.

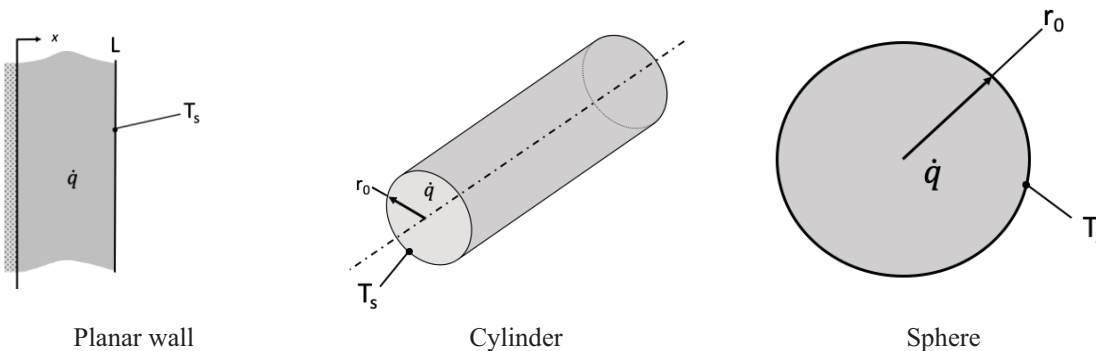

Figure A6.2. 1-D conduction systems with uniform thermal energy generation: a plane wall with one adiabatic surface, a cylindrical rod, and a sphere.

1-D, Steady-State Solutions to the Heat Equation for Uniform Generation in a Plane Wall, a Solid Cylinder, and a Solid Sphere with One Adiabatic Surface.

---

#### Temperature Distribution

Plane Wall 
$$T(x) = \frac{\dot{q}L^2}{2k} \left( 1 - \frac{x^2}{L^2} \right) + T_s$$

Circular Rod 
$$T(r) = \frac{\dot{q}r_o^2}{4k} \left( 1 - \frac{r^2}{r_o^2} \right) + T_s$$

Sphere 
$$T(r) = \frac{\dot{q}r_o^2}{6k} \left( 1 - \frac{r^2}{r_o^2} \right) + T_s$$

#### Heat Flux

Plane Wall 
$$q''(x) = \dot{q}x$$

Circular Rod 
$$q''(r) = \frac{\dot{q}r}{2}$$

Sphere 
$$q''(r) = \frac{\dot{q}r}{3}$$

#### Heat Rate

Plane Wall 
$$q(x) = \dot{q}xA_x$$

Circular Rod 
$$q(r) = \dot{q}\pi Lr^2$$

Sphere 
$$q(r) = \frac{\dot{q}4\pi r^3}{3}$$

---



## Standard Operating Procedure

*ENTER TITLE HERE*

<b>Department:</b>	
<b>Completion Date:</b>	
<b>Approval (by PI / Lab Manager) Date:</b>	
<b>Principal Investigator:</b>	
<b>Principal Investigator Signature:</b>	
<b>Internal Lab Safety Coordinator/Lab Manager:</b>	
<b>Lab Phone:</b>	
<b>Office Phone:</b>	
<b>Emergency Contact:</b>	<i>(Name and Phone Number)</i>
<b>Location(s) covered by this SOP:</b>	<i>(Building/Room Number)</i>

**Type of SOP:**  Process  Hazardous Chemical  Experiment  Equipment Use

**Contents**

**Purpose and Scope**  
**Responsibility**  
**Materials and Equipment**  
**Definitions**  
**Specific Safety and Environmental Hazards**  
**Hazard Control**  
**Location of nearest emergency safety equipment**  
**Shipping and Receiving Requirements**  
**Step-by-step Operating Procedure**  
**Special handling procedures, transport, and storage requirements**  
**Preventive Maintenance**

**Monitoring and Safety Systems**  
**Waste Disposal/Cleanup**  
**Emergency Response Plan Procedure**  
**References**  
**Preventive maintenance**  
**Monitoring and Safety Systems**  
**Emergency Response Plan**  
**References**  
**Training Requirement**  
**Additional Notes and Attachments**  
**Documentation of Training**



Title of SOP

**Read and review any applicable manufacturer/vendor safety information before developing standard operating procedure and performing work**

**\*\*\* NOTE:** Each section needs to be complete with clear and detailed information based on the blue/italic font instruction. SOP must be approved and dated by the PI or lab supervisor.

**1. Purpose and Scope of Work/Activity:**

*This section identifies the goal of the SOP to answer why the SOP is being written. It needs to be detailed enough so that the intended user can recognize what the document covers. Briefly summarize the process including an estimate of how long the process takes and how frequent it will be conducted.*

*The scope section identifies who needs to follow the procedure and what the procedure covers. This allows everyone to have the same starting point. You can also add a photo of your equipment.*

**2. Responsibility**

*Identify the personnel that have a primary roles in the SOP and describe how their responsibilities relates to this SOP. If necessary, include contact information.*

**3. Materials and Equipment**

*List all of the materials needed to complete the procedure. If the procedure is written to operate a specific piece of equipment, make sure the user guide for the machine is listed in the Reference section, and that users have been trained on operating the equipment prior to performing the procedure.*

*List all of the materials needed to complete the procedure. List conditions that pose a hazard such as extreme temperature, elevated pressure, reduced pressure, etc. and list the potential hazards*

**4. Definitions**

*In this section, define any acronyms or abbreviations that are used in the procedure.*

**5. Specific Safety and Environmental Hazards:**

*List any warning or precautions before performing a procedure.*

**6. Hazard Control(s)**

**7.1. Engineering/Ventilation Controls**



Title of SOP

*In this section describe any specific engineering controls which are required to prevent operator exposures to hazards such as fume hood, interlocks on equipment, explosion shielding, ultraviolet light shielding, and safety features on equipment.*

**7.2. Administrative Controls**

*In this section describe any specific administrative controls which are required to prevent operator exposures to hazards such as*

- Proper labeling and storage*
- Good laboratory housekeeping*
- Testing equipment function and inspecting for damage prior to use*
- Shift-hand-off procedure,*
- Equipment status reporting*
- Mothballing process, etc.*

**7.3. Personal Protective Equipment**

*State the personal protective equipment selected and when it's required, and specific hygiene practices if needed. For example: Safety glasses, nitrile gloves, cryo gloves, absorbent bench paper, respiratory protection, lab coat and body protection, etc.*

**7. Location of nearest emergency safety equipment**

**ITEMS**

**8. Shipping and Receiving Requirements**

*Describe shipping or receiving requirement, especially for highly toxic, highly reactive, unstable, highly flammable and corrosive materials.*

**9. Step-by-step Operating Procedure**

*Provide the steps required to perform this procedure.*



**SUBJECT INDEX****A**

Air 64, 67, 102, 109, 118, 155, 156, 160, 168,  
172, 174, 175  
compression 64  
compressors 67  
conditioners 102, 160, 172, 174, 175  
cycle machine 168  
enthalpy 109  
injection rate 118, 155, 156  
Aircrafts 121, 124, 126, 130, 168  
flying 130  
powered 168  
Airplane flying 135  
Analysis 105, 146, 179  
engineering 179  
open-system 146  
thermodynamic system 105  
Applications 1, 3, 12, 22, 28, 66, 70, 81, 84,  
93, 122, 123, 138, 148  
industrial 1  
renewable energy 66  
waste 84  
Atmospheric pressure 144

**B**

Bernoulli constant 126  
BFW pressure 118  
Bimetallic 3, 38  
devices 3  
thermometers 38  
Boiler(s) 60, 61, 62, 69, 70, 72, 73, 74, 81,  
102, 103, 104, 106, 107, 108, 109, 117,  
118  
commercial 106  
efficiency measures 106  
feed water (BFW) 70, 72, 73, 81, 106, 108  
functions 109  
natural-gas-fueled 104  
waste heat 109  
water-tube 61

Brake 144, 150  
hysteresis 150  
magnetic powder 150  
Brayton cycle processes 63  
Burning fossil fuels 106

**C**

Calibration 16  
constant 16  
equation 16  
Calorically perfect gas (CPG) 140, 141  
Chemical energy 102, 104, 108, 150  
Chilled water return (CWR) 70, 76, 77, 78  
Chiller and boiler building 73  
Combined-cycle configuration 60  
Combustion 64, 68, 71, 104, 106, 113, 139,  
140, 141, 142, 147, 148, 154, 155, 156  
fuel-rich 155  
energy 148  
expansion strokes 155  
process 142, 147  
turbine generator (CTG) 68, 71  
turbines 64, 113  
Commercial devices 39  
Compressed 64, 138, 161, 166  
air 64, 138, 166  
natural gas plants 161  
Compression 121, 142, 148, 154  
ratio 142, 148, 154  
shocks 121  
stroke 148  
Compressor 63, 64, 66, 70, 143, 161, 163,  
169, 170, 171, 174  
air-conditioning 143  
drive 70  
irreversible 174  
Constant 61, 64, 171  
enthalpy process 171  
pressure heat addition 61  
pressure heat rejection 64

Yun Wang

All rights reserved-© 2023 Bentham Science Publishers

## **Subject Index**

Continuous emissions monitoring system (CEMS) 72  
Convection, natural 40  
Cooling 36, 39, 66, 68, 73, 74, 75, 76, 77, 79, 103, 105, 106, 119, 152, 166, 167, 171, 172  
  effect 171  
  process 167  
  towers 66, 68, 73, 74, 75, 79, 103, 106, 119  
  water 105, 152  
CW production cycle 70  
Cycle engines, diesel 138, 141, 158

## **D**

Design 60, 66, 69, 73, 75, 77, 81, 82, 87, 93, 114, 156, 161, 167, 168  
  engineering 73  
  pipe system 81  
  procedures 114  
Devices 13, 17, 37, 66, 82, 100, 102, 121, 138, 150, 155, 161, 167  
  electrical 13  
  engine-testing 150  
  power-producing 161  
  thermodynamic 66  
Distributions 26  
  probability density 26  
  smooth 26  
Dynamometers 150, 151, 152  
  electrical 151  
  water brake 152

## **E**

Economics, engineering 13  
Efficiency 66, 104, 119, 171, 173  
  boiler-economizer 119  
  chiller 66  
  isentropic 171  
  power-plant 104  
  refrigerator 173  
Electrical BOP devices 67  
Electricity production 113

## **Practical Handbook of Thermal Fluid Science 229**

Energy 1, 40, 64, 80, 103, 104, 105, 119, 138, 149, 167  
  electrical 167  
  mechanical 64, 104, 138  
Energy conversion 60, 81, 102  
  steam turbines for 60, 81  
  efficiency 102  
Engine 37, 140, 141, 142, 143, 144, 146, 147, 148, 150, 152, 153, 154, 155, 156, 157, 158  
  combustion 147  
  configuration 140  
  fuels 148  
  heat removal 37  
  multi-cylinder 142  
  oils 156  
  single-cylinder 144  
Equation, theoretical 184  
Equipment, mechanical refrigeration 160

## **F**

Fluid 81, 121  
  dynamics 81  
  flow phenomena 121  
  mechanics equations 81  
Fluid velocity 1, 122, 123, 124  
  measurement 123  
Food industry 165  
Force 40, 88, 156  
  friction 156  
  gravitational 40  
  viscous shear stress 88  
Fossil fuels 60, 69, 102, 104  
  boilers burn 60  
Freezer chamber 173  
Friction factor 90, 91, 92, 93, 94, 95, 96, 97, 99  
  correlations 94  
  fanning 91, 93  
Friction power 144, 157, 158  
Fuel 37, 60, 61, 64, 104, 105, 106, 107, 108, 109, 113, 116, 138, 139, 145, 146, 147, 148, 149, 150, 153, 155, 157, 158

burnt 139  
 combustion 60, 61, 64, 106, 138  
 consumed 145  
 diesel 150  
 flow rate fluctuates 153  
 nuclear 37, 104  
 spraying 64  
 system 153

**G**

Gas 1, 36, 40, 66, 67, 71, 72, 118, 143, 149,  
 153, 159, 166, 168, 171  
 compressed 66, 166, 168  
 compression 166  
 flow rate 153  
 greenhouse 118  
 hot atmospheric 36  
 Gas flows 72, 84  
 hot turbine exhaust 72  
 Gasoline 1, 2, 93, 109, 138, 144, 145, 149,  
 150, 151, 153  
 density 145  
 engines 138, 144  
 motor 150  
 vapor 138  
 vehicles 1  
 Gas turbine (GT) 64, 68, 69, 72, 73, 79, 105,  
 109, 113, 114, 118  
 generation (GTG) 73, 113, 114, 118  
 industry 113  
 operation 64  
 power generation 64, 68, 79  
 Gaussian 26, 28  
 frequency distribution 26  
 regression 28  
 Gaussian distribution 19, 20, 21, 24, 25, 26,  
 27, 32, 33, 34  
 function 19  
 reduced 20, 21, 33  
 Gearboxes 155, 158  
 Generators 62, 64, 68, 71, 72, 113, 143, 150  
 combustion turbine 68, 71  
 electric 62, 113, 150

electrical 64, 143  
 heat recovery steam 71, 72  
 Gloves 7, 9  
 chemical-resistant 7  
 cryogenic 9  
 protective 7

**H**

Harvesting techniques 160  
 HAVC system 76  
 Hazard(s) 7, 8, 11, 12  
 chemical 7, 8, 11, 12  
 communication 11, 12  
 workplace 7  
 Hazardous 7, 9, 10, 166  
 communication 9  
 handling 7  
 waste training 10  
 Heat 1, 36, 39, 40, 44, 61, 63, 64, 66, 67, 71,  
 72, 102, 104, 105, 106, 108, 110, 111,  
 118, 146, 148, 158, 163, 165, 167, 168  
 absorption 163, 165  
 auxiliary 67  
 convective 44  
 exchanger efficiency 110  
 loss 64, 106, 110, 118, 146, 148, 158  
 molten salts release 104  
 pump 168  
 radiation 39  
 recovery steam generator (HRSG) 71, 72  
 release 165  
 Heat removal rate 36, 146, 167  
 sensible 146  
 transfers 167  
 Heat transfer coefficient measurement 44, 68,  
 69, 107, 119  
 waste 68, 69, 107, 119  
 Heat engines 60, 61, 64, 102, 138  
 reciprocating 138  
 Heat pump(s) 102, 163, 164, 167, 169, 172  
 cycles 102  
 loading 172

## ***Subject Index***

Heat rejection 62, 68, 73, 74, 102, 104, 139, 140, 161, 162, 163  
waste 68  
Heat transfer 36, 162  
forced convective 36  
latent 162  
sensible 162  
High 68, 69, 71, 76, 77, 79, 118, 119, 168  
amplitude sound waves 168  
temperature water (HTW) 68, 69, 71, 76, 77, 79, 118, 119  
High-pressure 9, 61  
gas safety training 9  
water 61  
High voltage 10  
hazards 10  
training 10  
Honeycomb flow straightener 127  
HTW 69, 71, 74, 77  
pressure 77  
production cycle 74  
system 71  
temperature 69, 77

## **I**

Ice 36, 37, 66, 67, 102, 155, 160, 172, 173, 174  
automobile 37  
based vehicles 155  
harvesting 160  
melting 172  
storage 66  
Industrial 3, 37  
development 3  
processes 37  
Industry 60, 81, 83, 106, 123, 165  
automotive 165  
Infrared sensors 3  
Intake 144, 154  
strokes 154  
vacuum 144  
Isentropic 62, 64, 140, 141

## ***Practical Handbook of Thermal Fluid Science 231***

compression-expansion relationships 140, 141  
expansion 62, 64

## **K**

Kinematic viscosity 90  
Kinetic energy 36, 39, 60, 91, 166, 171  
rotating 60

## **L**

LHV of natural gas 108  
Liquid 2, 9, 38, 39, 40, 61, 66, 69, 70, 72, 81, 83, 84, 106, 163, 164, 167, 171  
condensate flows 72  
in-glass thermometer 2  
in-tube thermometers 38, 39  
low-pressure 61  
low-temperature refrigerant 163  
nitrogen 9  
transport 81  
Lower heating value (LHV) 108, 109, 113, 146, 147, 154  
Lubricating oil coolers 73  
Lumped capacity assumption 44

## **M**

Magnetic powder 152  
Manometer fluid 96  
Mass 1, 3, 42, 64, 76, 85, 105, 116, 117, 130, 150, 172, 173, 176, 181  
balance equation 85  
consumption 176  
flow rate 64, 116, 117, 130, 172, 173  
Material 3, 38, 40, 48, 95, 167  
elastic 3  
Mathematical equations 177  
Measure 4, 121  
flow velocity 121  
heat loss 4

**N**

Natural gas (NG) 36, 60, 69, 102, 103, 108, 116, 118  
 Navier-stokes equations 122  
 Nitrogen-blanket tank pressure 79  
 Noncombustible renewable energy 103  
 Nuclear 36, 61, 62, 104  
   power plants 36, 62, 104  
   reaction 61, 104

**O**

Open system 105, 117, 146  
   analysis 105, 146  
   balance equations 117  
 Operation, vehicle 157  
 Ordinary differential equation (ODE) 89  
 Outlier detection methods 28  
 Oxygen fraction 116  
 Ozone depletion 165

**P**

Paths, thermodynamic 118  
 Personal protective equipment (PPEs) 7, 9, 12  
 Photokeratitis 9  
 Pipe 92, 100  
   rough 100  
   rough-walled 92  
 Pipe flow 1, 29, 81, 87, 88, 90, 92, 94, 95, 96, 97, 99, 100, 171  
   laminar 92, 96  
   networks 81, 171  
   theory 95  
   turbulent 92, 94, 97  
 Piston 61, 138, 141, 142, 143, 148, 156  
   compression 148  
   stroke 143  
 Pitot-static tube design 123  
 Pitot tube 4, 121, 123, 124, 125, 126, 127, 128, 129, 130, 135  
   ice-plugged 121  
 Plant, steam power 119

Power 13, 36, 37, 138, 139, 143, 144, 145, 155, 158, 161, 164, 169  
   electrical 169  
   nuclear 13  
   transmission 155  
 Pressure 82, 122, 123, 169, 174  
   dynamic 122, 123  
   gauges 169, 174  
   hydraulic 82  
 Pressure measurement 81, 83, 169  
   instruments 83  
 Pressure transducer 16, 123, 125  
 Probability distribution function 22  
 Process 61, 62, 63, 64, 107, 139, 147, 161, 163, 166, 168, 171  
   condensation 171  
   constant-pressure 161  
   heat-addition 147  
   isentropic 161, 171  
 Properties 1, 174  
   popular heat transfer 1  
   thermodynamic 174  
 Protection 6, 7, 8, 9, 12  
   skin 9  
 Protective eye 9

**Q**

Queuing theory 23

**R**

Radiation 1, 3, 9, 36, 39, 40, 165  
   ultraviolet 165  
 Random motions 39  
 Rankin 62, 169  
   cycle steam turbine 169  
   cycle processes 62  
 Reduction, fuel consumption 131  
 Refrigeration 160, 161, 162  
   mechanical 160, 161  
   systems 161, 162  
 Refrigeration cycle 1, 67, 70, 161, 162, 164, 168, 169, 170

## **Subject Index**

mechanical compression vapor 70  
mechanical vapor-compression 168  
vapor-compression 1  
Refrigerators 161, 163, 164, 165, 166, 169,  
172, 174, 175  
vortex tube 166  
Reliability theory 23  
Renewable resources 149  
Residential refrigerators 160, 173  
Resistance 38  
electric 38  
temperature detectors (RTD) 38  
Reynolds number 12, 86, 87, 90, 91, 92, 93,  
94, 96, 97, 98, 99

## **S**

Semi-empirical ozone 165  
Shear stress 88  
Skin cancer 9  
Solar 60  
panels 60  
thermal power plants 60  
Steam 6, 60, 61, 62, 68, 69, 70, 71, 72, 79,  
104, 106, 107, 112, 113, 118  
condensate (SC) 68, 70, 112, 118  
high-pressure 60, 106, 113  
pipes 6  
pressure 62  
system pressure 71  
Steam production 60, 69, 72, 106, 109  
high-pressure 72  
Steam turbine (ST) 60, 61, 62, 68, 69, 70, 71,  
72, 73, 74, 102, 103, 104, 106, 113, 114,  
117, 118  
design 61, 62  
generator (STG) 68, 71, 73, 113, 114, 117,  
118  
operation 61, 71, 104  
power generation 61, 68, 104

## **T**

Tank, thermal energy storage 66, 77

## **Practical Handbook of Thermal Fluid Science 233**

Thermal 1, 7, 13, 37, 38, 39, 40, 42, 50, 60,  
102, 138, 146, 154, 158, 163  
conductivity 1, 42, 50  
diffusivity 1  
efficiency 37, 102, 138, 146, 154, 158, 163  
expansions 38, 39  
solar 13, 60  
Thermal energy 36, 42, 60, 64, 66, 67, 68, 69,  
70, 72, 102, 104, 106, 113  
absorbing 70  
storage 66, 68  
system 66  
Thermocouple voltage 18  
Thermodynamic processes 62, 64  
Thermoelectric 3, 38, 160, 167  
coolers 160  
effect 3, 38  
Thermometers 3, 15, 38, 39  
powered 38  
Thermostatic expansion valve (TEV) 163  
Throttling process 171  
Torque 144, 145, 146, 150, 151, 152, 155,  
156, 158  
arm 150, 151  
conversions 155  
effective 145, 146  
Transfer 40, 44  
convective heat 40  
process 44  
Transparent tubes 169  
Tubes 38, 72, 79, 81, 82, 83, 107, 110, 112,  
123, 124, 125, 128, 160, 166, 167  
concentric 125  
narrow 38  
static 123, 124, 128  
vortex 160, 166, 167  
Turbulence 86, 163, 170  
downstream 86

## **V**

Vapor 161, 162, 167, 169, 170  
compression 161, 162, 167, 170  
pressure 169

Vehicles, gasoline engine 150  
Voltage 2, 3, 16, 17, 33, 38  
    electric 38  
    temperature-dependent 38  
Vortex tube for refrigeration 175

